

## 2.0 - 3.0 Tonne (manual)

Thwaites

MACH 2020, 2022,  
2023, 2070, 2073.

# Operator's Instruction Manual



Mach 2022 - 2 Tonne powerswivel

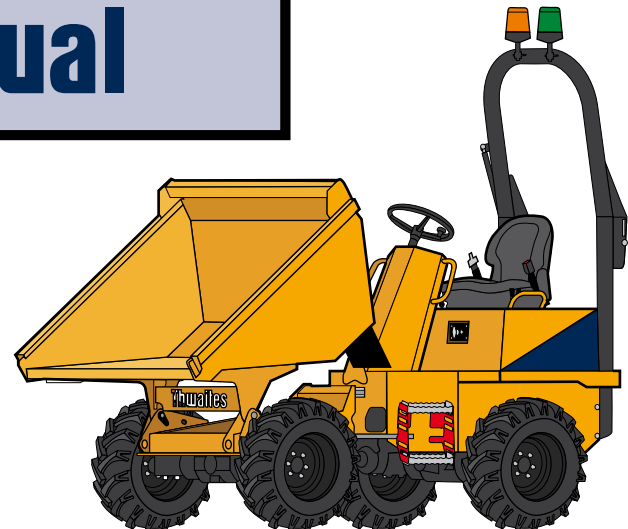

Mach 2020 - 2 Tonne front tip

## Thwaites Limited puts Safety First

It is the policy of Thwaites Limited to promote safety in the operation of its machines and to create a general awareness of site safety and safe working practices for the operators of its machines.

This Operator's Instruction Manual is intended for both new and experienced machine operators. It should remain with the machine at all times. All operators should be aware of its location and contents.

It is important that all operators are fully trained and familiar with the machine and that they have read and understood the information contained within this book before they attempt to operate in the site conditions for which the machine was designed.

This book details practices and operations which Thwaites Limited recommends. DO NOT operate this machine in ways other than those detailed within this book.

This machine is designed for customary construction site operations, and the transportation of bulk materials commonly carried on such sites; that is their 'intended use'. Under certain controlled conditions the dumper may be used for towing wheeled loads.

Due to the varied nature of the operation of site dumpers and the absence of an agreed test standard, any figures quoted by Thwaites in relation to vibration values and exposure are for reference purposes only. It is the responsibility of the employer to assess vibration exposure based on the actual site conditions, and operating practices, at the point of use.

**Hand Arm Vibration** - The daily exposure Action/Limit Values of between 2.5 - 5.0m/s<sup>2</sup> (A8) are unlikely to be exceeded in an eight-hour reference period.

**Whole Body Vibration** - The daily exposure can only be accurately determined at the point of use. This exposure must be managed in respect of the Action/Limit Values of 0.5 and 1.15 m/s<sup>2</sup> (A8) respectively.

Employers should not rely solely on published vibration figures when undertaking risk assessments. Depending on the site conditions, cycle times may need to be adjusted in order to reduce operator exposure levels.

Vibration values based on typical duty cycles are available on request from Thwaites. These may be used for reference purposes only.

## Safety Symbols



- Attention!
- Become Alert!
- Your safety is involved



- Correct action



- Incorrect action/procedure which should NOT be carried out

## Signal words:

Signal words are used on the machine and within this manual to identify levels of hazard seriousness



**DANGER**



**WARNING**



**CAUTION**

# 1 Before operating this machine

**Thwaites**



Read this operator's instruction manual

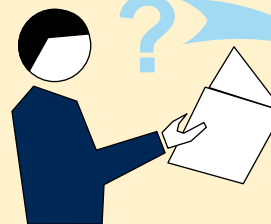

**Thwaites**  
Distributor

- 1 Contact your Thwaites dealer in case of further questions
- 2 Learn to operate this machine
- 3 Ensure you are fit to operate
- 4 Wear correct safety clothing and ensure safety equipment is available

Complete checks in section



before starting the engine

# 1 Safety label identification

Thwaites

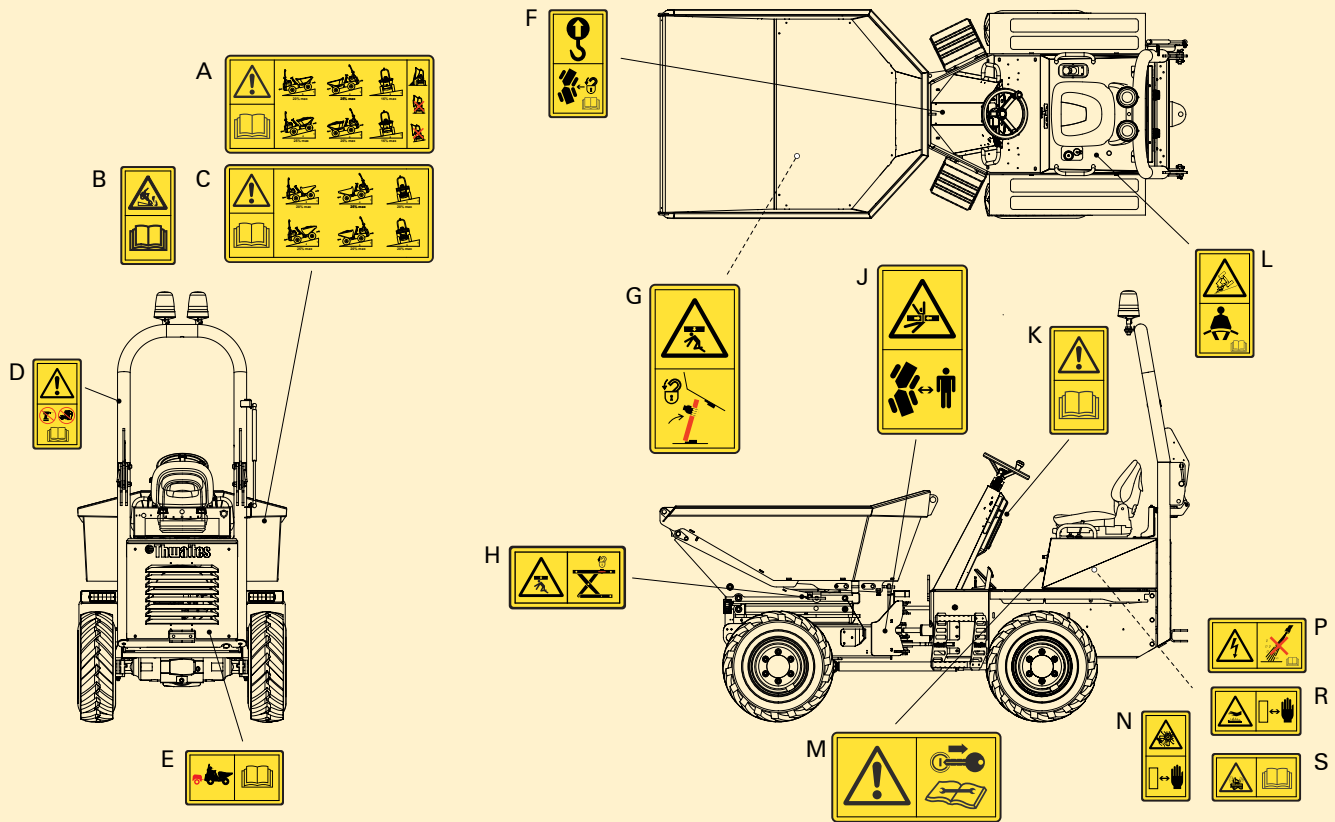

Complete checks in section **1** before starting the engine

# 1 Safety label identification

## Safety labels

The safety labels fitted to these machines are to warn the operator or bystanders of possible hazards.

- Be sure you fully understand the content and position of the labels.
- Ensure labels are clean and in good condition, do not clean labels with solvents.
- Replace lost or damaged safety labels.

 There are also other labels in addition to the safety labels, handle these labels in the same way.  
Orientation of labels may vary from those shown.

Item	Description	Qty	Item	Description	Qty
A	Gradient Front Tip - Read the operator's manual before working on gradients	1	J	Crushing of whole body - Stay a safe distance from articulation area	2
B	Stability hazard - Do not discharge load when working on sloping ground	1	K	Warning - Read the operator's manual before you operate the machine	1
C	Gradient Powerswivel - Read the operator's manual before working on gradients	1	L	Crushing hazard due to machine roll over - Always wear seat belt	1
D	Warning roll over protective structure (ROPS) - Never modify structure	1	M	Warning engine maintenance - Read the service manual before working on the machine	1
E	Warning - Read the operator's manual before towing a trailer	1	N	Warning severing of finger or hand - Keep hands a safe distance from rotating parts (under engine cover)	1
F	Warning lift point - Read the operator's manual before lifting the machine	1	P	Electrical shock - Do not use pressure washer on electrical items (under engine cover)	1
G	Crushing of whole body - Never work under an unpropped skip	1	R	Hot surface - Keep hands a safe distance from hazard (under engine cover)	1
H	Crushing of whole body - Never work under an unlocked scissor frame (Hi swivel model)	1	S	Warning hot fluid under pressure - Read the operator's manual (under engine cover)	1

Complete checks in section  before starting the engine

# 1 Before operating this machine

Thwaites

## Walk Around The Machine

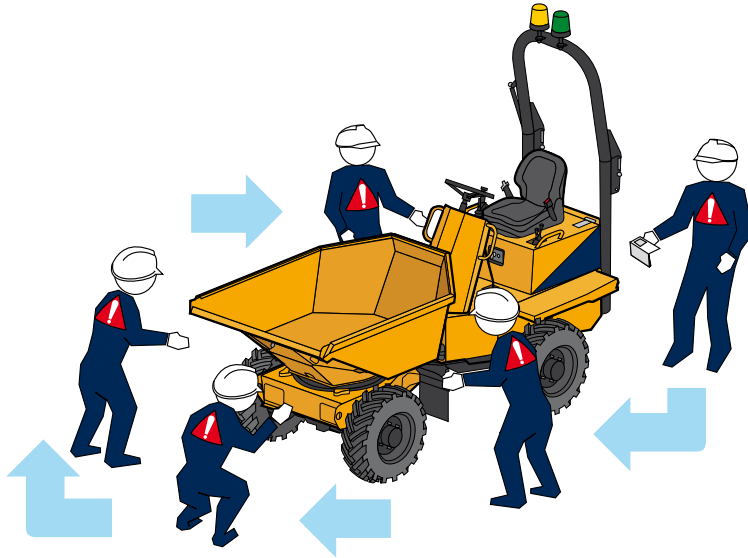

### Visually check the machine

- 1 Are the chassis lock and the skip lock disengaged?
- 2 Are the controls, crush zone or hydraulic rams clean, and clear of any debris?
- 3 Is the Roll-Over Protective frame (ROPS frame) secure, fully upright and undamaged?
- 4 Is the seatbelt anchorage secure and serviceable?
- 5 Are the covers and mudguards secure?
- 6 Are the hoses free from fluid leaks?
- 7 Are all safety decals legible?
- 8 Are the tyres free of cuts or splits?
- 9 Are all bolts tight and in position?
- 10 Are the steering wheel and the steering column undamaged?
- 11 **Have the daily maintenance tasks been performed? (See section 5)**

Report all faults immediately.



**DO NOT OPERATE THE MACHINE UNTIL ALL FAULTS HAVE BEEN RECTIFIED**

Complete checks in section



before starting the engine

# 1 Before operating this machine

Thwaites



## Mount the machine and check the controls

- 1 Use the grabrails and foot steps provided to manoeuvre into seating position. Face the machine at all times when mounting and dismounting
- 2 Is the engine cover secure and locked?
- 3 Adjust the seat position for comfort and easy access to controls
- 4 Fasten the seatbelt. Adjust accordingly for safety and comfort
- 5 Is the hand brake ON?
- 6 Set the transmission to neutral
- 7 Does the foot brake feel firm?
- 8 Do not operate the machine without understanding all its controls as described in the following pages



## WARNING

Seatbelt **MUST BE WORN** when operating machines fitted with ROPS frame.

Complete checks in section



before starting the engine

# 1 Layout of controls

**Thwaites**

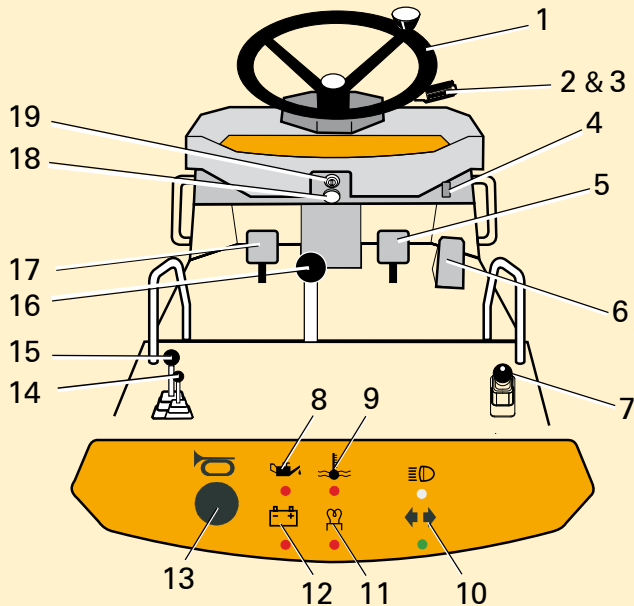

## Control location & functions

1. Steering wheel
2. Direction indicator selector -  
forward = left turn - back = right turn\*
3. Lights -  
twist 1 = sidelights ON  
twist 2 = headlights ON\*
4. Hazard warning light switch\*
5. Foot brake pedal
6. Throttle pedal
7. Hand brake lever
8. Engine oil pressure warning light
9. Water temperature warning light
10. Direction indicator pilot light\*
11. Heat/start pilot light
12. Battery charging warning light
13. Horn push
14. Raise-skip lever (hi swivel model only)
15. Tip-skip lever (Fwd tip model)  
Tip-skip and rotate-skip lever  
(powerswivel and hi swivel models)
16. Gear lever
17. Clutch pedal (start inhibitor)
18. Ignition & hand brake warning buzzer
19. Ignition switch

\* Optional items

Complete checks in section



before starting the engine



# 1 Layout of battery

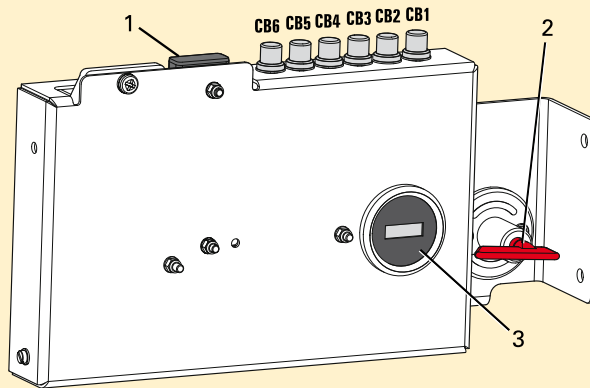
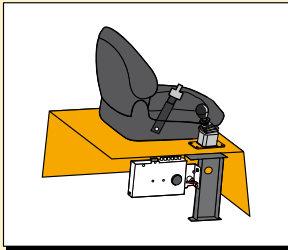

- 1 Maxi fuse
- 2 Isolater switch
- 3 Hour meter
- CB1 Transmission
- CB2 Power
- CB3 Lights\* / Becon / Horn
- CB4 Hazard\* / Lights\*
- CB5 LH side lights\*
- CB6 RH side lights\*

\* Optional items

Complete checks in section



before starting the engine

# 1 Control functions – explained

Thwaites

## Seat Adjustment

- A – Turn knob to set driver weight
- B – Lift to slide seat assembly forwards/backwards
- C – Lift handle to adjust backrest

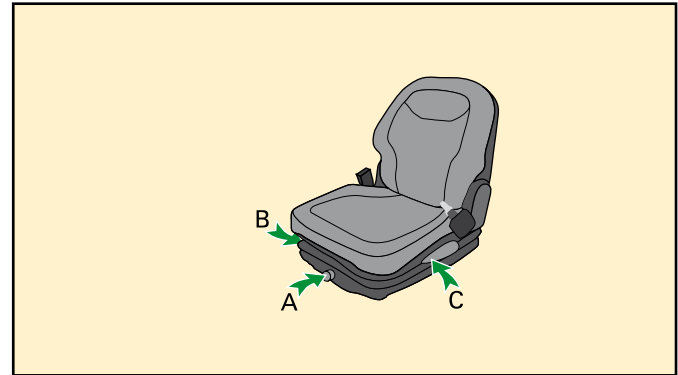

## Seatbelt

- Adjust length of belt when seated on machine
- Press buckle blade into buckle lock
- Pull belt webbing through buckle blade to remove slack

 *Seatbelt should not be worn loose, it should pass comfortably across hip bones and not the abdomen*

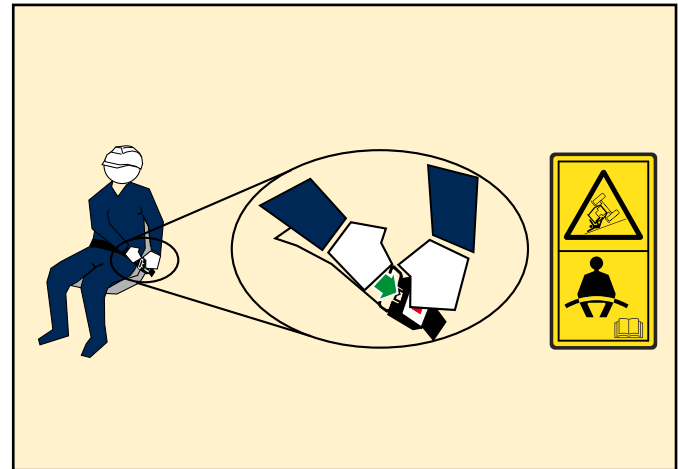

Complete checks in section  before starting the engine

# 1 Control functions – explained

Thwaites

## Tip-skip lever (forward tip model)

- Push forward to tip skip
- Push backwards to return skip

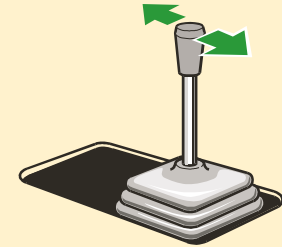
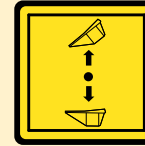

## Rotate-skip lever (swivel models)

- Raise skip 100 mm (4") to disengage pivot centring lock
- ☞ Rotate skip, fully lowered, to automatically engage centring lock
- Raise skip and push lever to the right to rotate skip to right
- Raise bucket and push lever to the left to rotate skip to left
- Push forward to tip skip
- Push backwards to return skip
- Increased engine speed reduces cycle times

☞ Movement of the skip is disabled if the steering wheel is moved (Priority Steering)

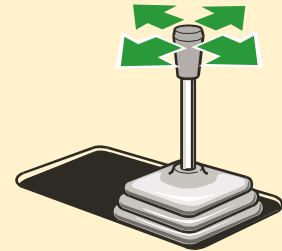
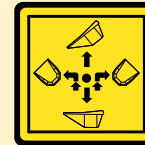

## Raise-skip lever (Hi swivel model only)

- Push forward to raise skip
- Push backwards to lower skip

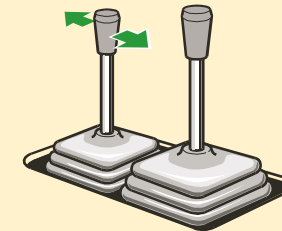

Complete checks in section



before starting the engine

# 1 Control functions – explained

Thwaites

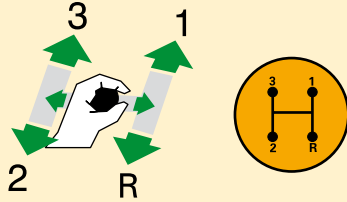

## Gear lever – left hand

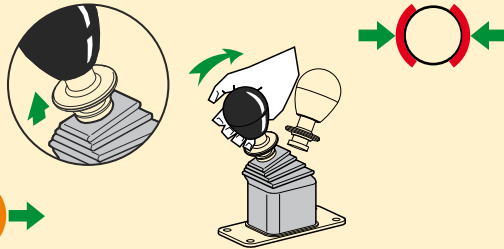
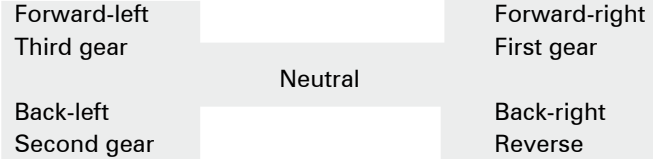

## Hand brake lever - right hand

- Use only when the machine is stationary (or in an emergency)
- Pull lever back to apply, lift collar pull back and release collar to lock.
- Lift collar and lever will move forward to release.



An audible warning device is fitted to your machine. This will sound if the parking brake is engaged whilst forward or reverse is selected and machine will not move.

Engine will not start if parking brake is not engaged.

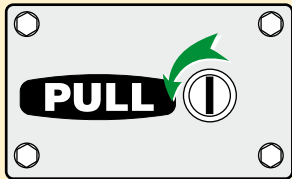

## Engine cover open/close

- Insert ignition key and turn anti-clockwise to unlock
- Pull handle to release and raise cover
- Lower cover, secure and lock before driving

Complete checks in section



before starting the engine

# 1 Control functions – explained

Thwaites

## Steering wheel

- Turn the wheel clockwise to turn machine to right
- Turn the wheel anti-clockwise to turn machine to left

 Ensure the non-steering hand is on the engine cover grab rail when using the spinner knob for low-speed single-handed steering.

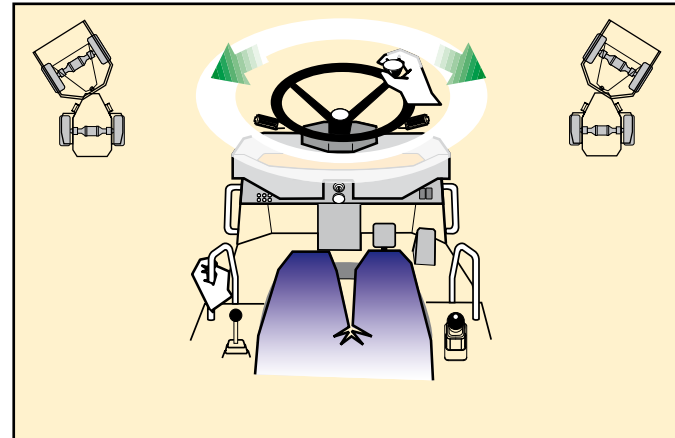

## Throttle pedal - right foot (A)

- Apply pressure to increase speed
- Reduce pressure from the pedal to reduce speed

## Foot brake pedal - right foot (B)

- Apply pressure down on the pedal to slow/stop the machine

## Clutch pedal - left foot (C)

- Press down before each gear change - select gear and release

 Start inhibitor fitted - press down clutch pedal before starting engine

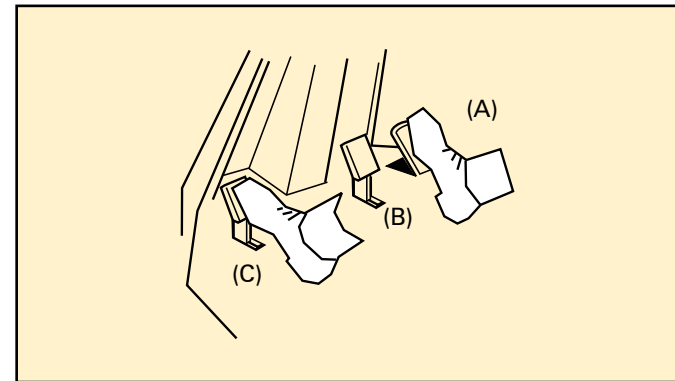

Complete checks in section



before starting the engine

# 1 Control functions – explained

**Thwaites**

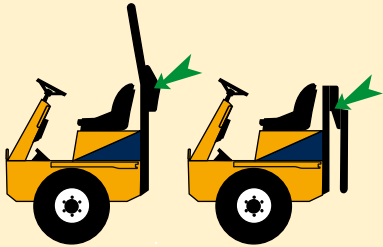

## Lowering and raising the folding ROPS frame

- Remove lynch pins and withdraw frame lock pins
- Lower frame and insert lock pins and lynch pins in new position
- Reverse the procedure to raise the frame
- Ensure all pins are secure before driving

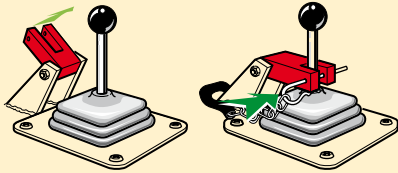

## Tipping lever lock (*optional*)

- Place yolk over tipping lever and secure with lynch pin

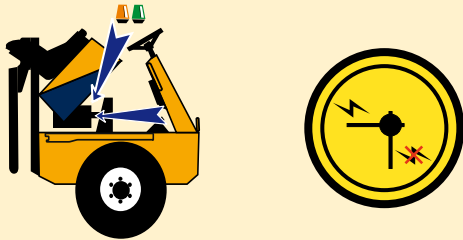

## Beacon stowage

- Unscrew and remove beacons
- Secure beacons on brackets provided beneath bonnet

## Battery isolator (beneath engine cover)

- Turn key anti-clockwise to isolate the battery power supply

Complete checks in section



before starting the engine

## 2 How to START and STOP the engine

Thwaites

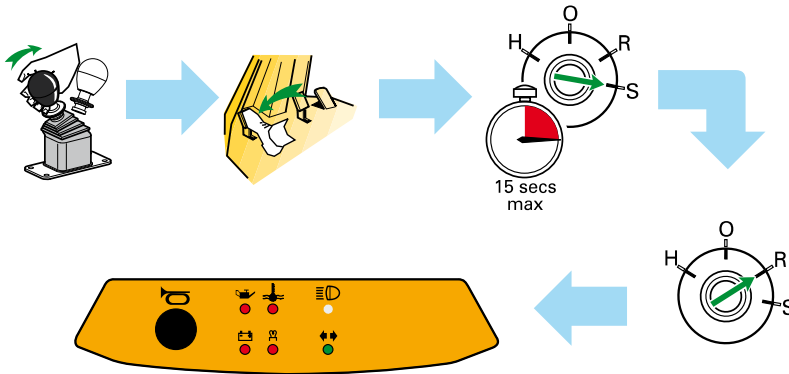

### To start the engine

- Apply hand brake
- Depress clutch pedal
- Cold start aid (when required)-

Turn key to position 'H'. When panel light extinguishes start engine (as above).

- Turn the key clockwise to the start position 'S'.

All panel lights self-test (illuminate) and should extinguish on start-up.

- Allow the engine to turn for a maximum of 15 seconds.

If the engine does not start within 15 seconds, return key to position 'O' and wait 30 seconds before turning to 'S' again.

- When the engine fires, release key.  
(Springs back to 'Run' position 'R').

### To stop the engine

- Turn key to position 'O'.



### ! WARNING

DO NOT START THE ENGINE UNLESS SEATED IN THE DRIVING POSITION.

### ! CAUTION

If a panel light remains on switch off engine (key to 'O') and investigate the problem.

### ! CAUTION

- Do not use unauthorised starting aids
- Do not tow or bump start

Complete checks in section  before loading the machine

## 2 Preliminary checks

Thwaites

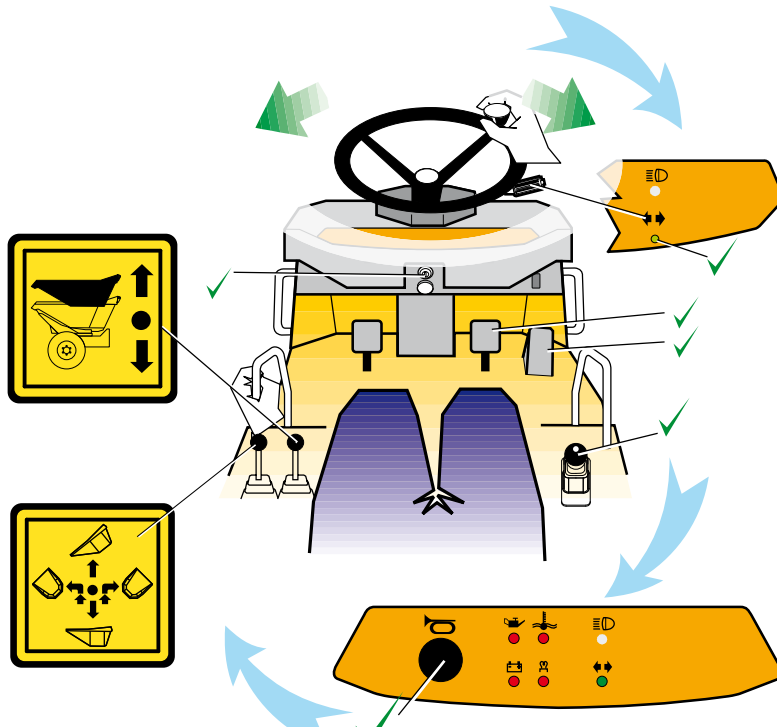

### Function checks - engine ON

#### Brakes

- Does the foot brake pedal feel firm?
- If the hand brake is on, and a gear is selected, a buzzer will sound and the drive may be disconnected.

#### Steering

- Rotate steering wheel clockwise and anti-clockwise

#### Electrics

- Does the horn sound correctly?
- Does the reverse alarm sound correctly?
- Are the beacons flashing?
- Are the lamps working correctly? (optional) –
  - \* Side lights
  - \* Head lights
  - \* Stop
  - \* Indicators
  - \* Hazards

#### Tip-skip lever/Rotate-skip lever

- Discharge/park skip
- Rotate - right to left/left to right. (powerswivel and Hi-Swivel models).

#### Raise-skip lever

- Raise/lower skip. (Hi-Swivel model only)



Complete checks in section



before loading the machine



## 2 Driving procedure and safe parking

Thwaites

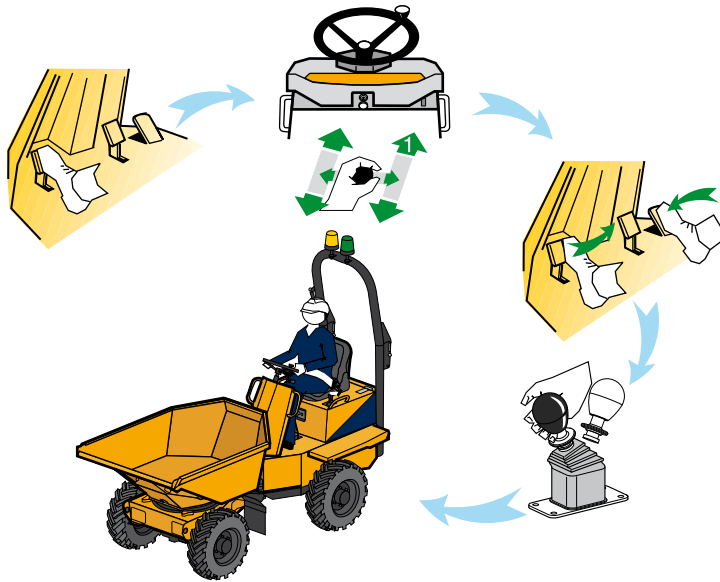

### CAUTION

- Novice operators should always start with forward motion on clear, level ground.
- A low gear should always be selected when a driver is unfamiliar with machine type.
- Do not mount or dismount the machine with the engine running.

### Moving from rest and stopping

 If green beacon option is fitted seat belt must be buckled.

- Depress clutch pedal
- Select first gear
- Slowly depress accelerator pedal, release clutch pedal and hand brake lever and move slowly
- Hold steering wheel with both hands
- Remove foot from accelerator pedal
- Brake gently to a halt, using foot brake pedal, and press clutch pedal to prevent stalling
- Apply hand brake and select neutral

### Changing speed/direction

- Release accelerator pedal
- Depress clutch pedal
- Select an alternative gear
- Release clutch pedal and press accelerator pedal
- Before changing direction (forward/reverse), stop the machine and engage the hand brake

### After operating – park safely

- Always leave skip empty when not in use
- Ensure machine is on firm level ground
- Apply hand brake
- Engage neutral
- Hydraulic system at rest in a safe condition
- Stop engine and remove key
- Lock engine cover

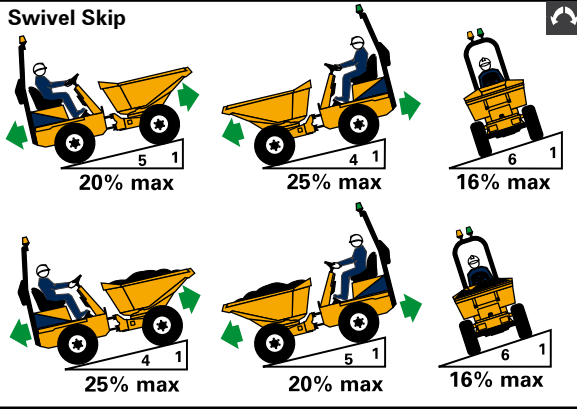
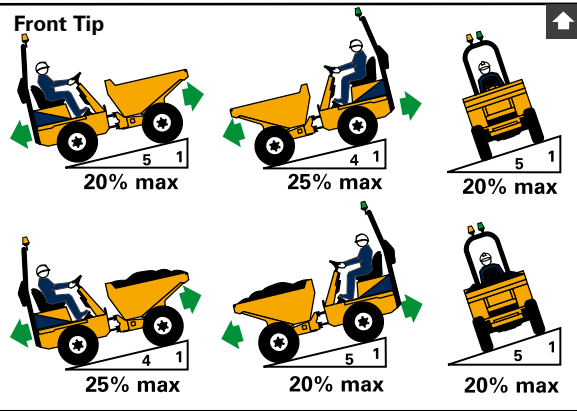

Complete checks in section  before loading the machine

**3** **DANGER****IMMEDIATE HAZARDS WHICH WILL RESULT IN SEVERE PERSONAL INJURY OR DEATH****Thwaites****Swivel Skip****Front Tip****WORKING ON GRADIENTS**

DO NOT exceed maximum stated gradients



DO NOT turn across gradients



DO NOT brake suddenly in wet, muddy, icy conditions or when operating on loose surfaces



DO NOT run downhill with controls in neutral



DO NOT operate skip-raise lever (Hi swivel model) on sloping ground.

**Check indicator**

Travel straight up, down or along a gradient



Keep speed to a minimum and use the foot brake to reduce speed when travelling down gradients



To prevent movement, always engage hand brake when stopped on sloping ground. Chock wheels securely when leaving the machine unattended



Always position swivel-skip in central lock

*Attention! Section 3 correct and incorrect working practices*

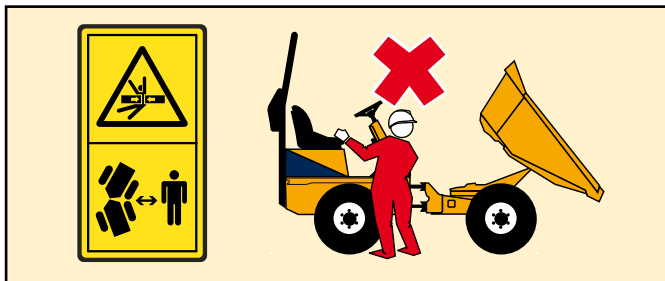
**3****DANGER****IMMEDIATE HAZARDS WHICH WILL RESULT IN SEVERE PERSONAL INJURY OR DEATH****Thwaites****CRUSH ZONE**

Stay clear of articulation area when the engine is running

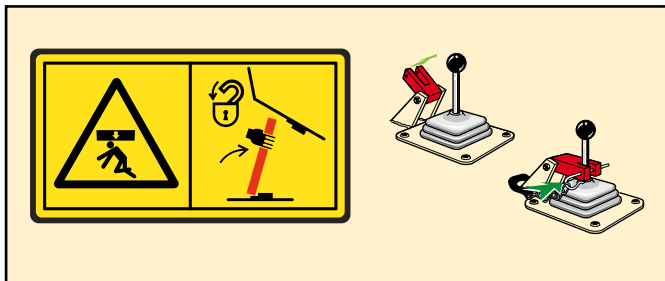

Never operate machine controls when standing on either side of machine

**WORKING UNDER A RAISED SKIP**

Lock skip safety prop during maintenance



Never work under an unpropped skip



When using skip safety prop engage tip-skip lever lock (if fitted)

*Attention! Section**correct and incorrect working practices*

**3****DANGER****IMMEDIATE HAZARDS WHICH WILL RESULT IN SEVERE PERSONAL INJURY OR DEATH****Thwaites****VISIBILITY**

The visibility maps show machines in standard build and travel configuration.

The maps provide an approximate indication of what can be seen by the operator and any blind spots when seated in the driving position wearing a seatbelt.

The maps have been provided to assist the operator / user and may be used as part of a risk assessment for the safe operation of the machine.

The machines are compliant with the visibility requirement given in EN 474-1 with regards to the rectangular boundary and a test object of 1.2m high and 0.3m wide and the 12m circular boundary.

- Check all around the machine before operation.
- Be sure all mirrors are adjusted before operating the machine (if fitted).
- All cameras and mirrors must be kept clean (if fitted).
- Be aware of all blind spots.

 The blind spot areas marked on the plan views of these maps are ground plane only

**WARNING**

Camera angles are factory set, any modifications to the machine configuration by any end user that may result in the restriction of visibility and will require a new risk assessment to be performed.

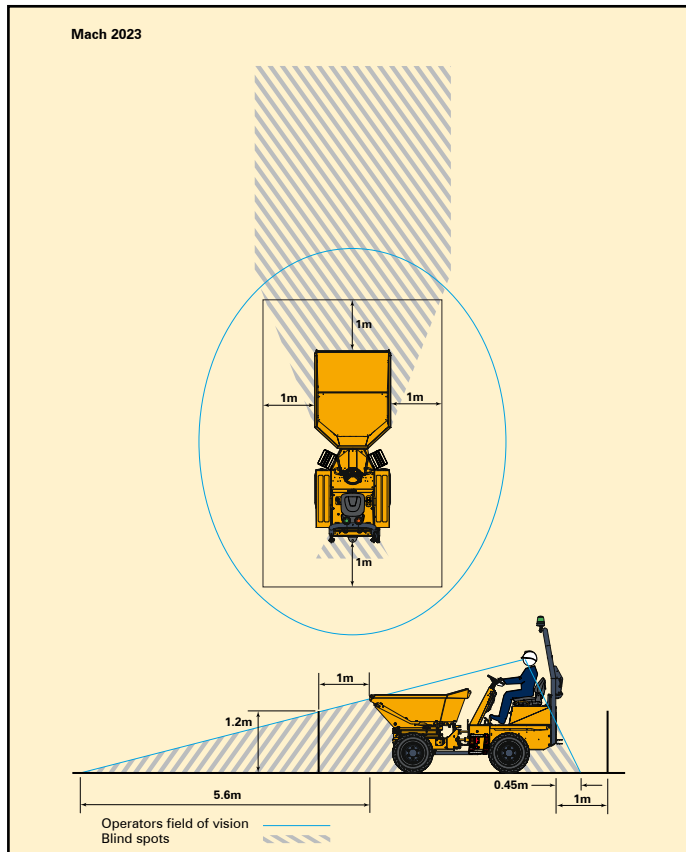
**3**

Attention! Section **3** correct and incorrect working practices

# 3

**DANGER**

**IMMEDIATE HAZARDS WHICH WILL RESULT IN SEVERE PERSONAL INJURY OR DEATH**

# Thwaites

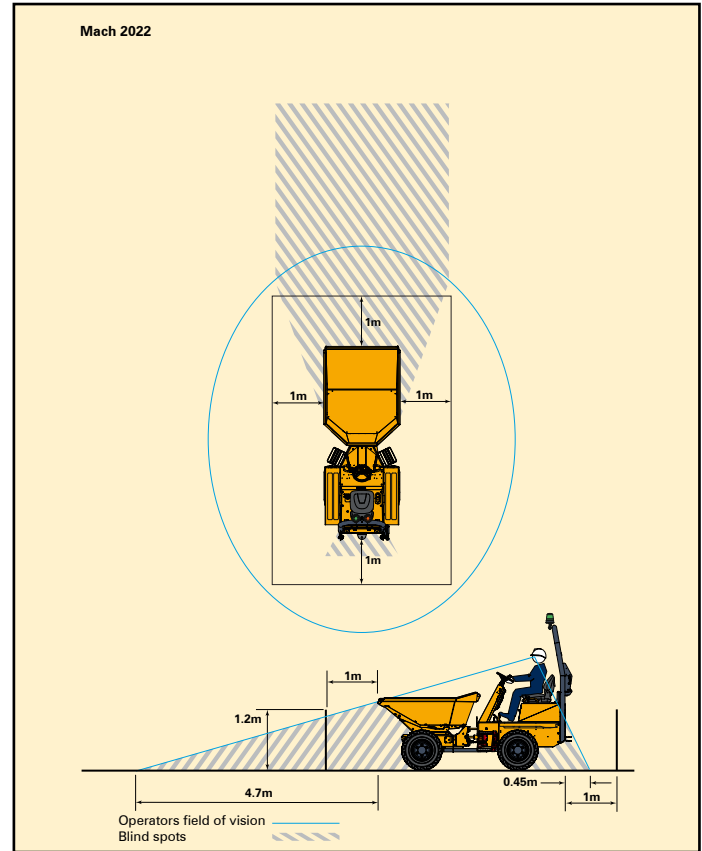
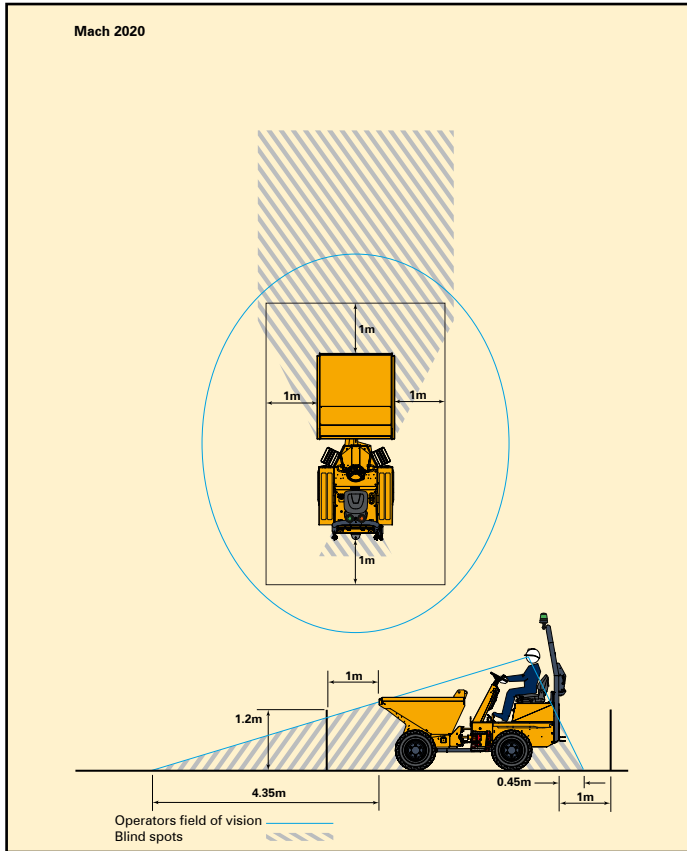

Attention! Section  correct and incorrect working practices

3



DANGER

IMMEDIATE HAZARDS WHICH WILL RESULT IN SEVERE PERSONAL INJURY OR DEATH

Thwaites

Mach 2070

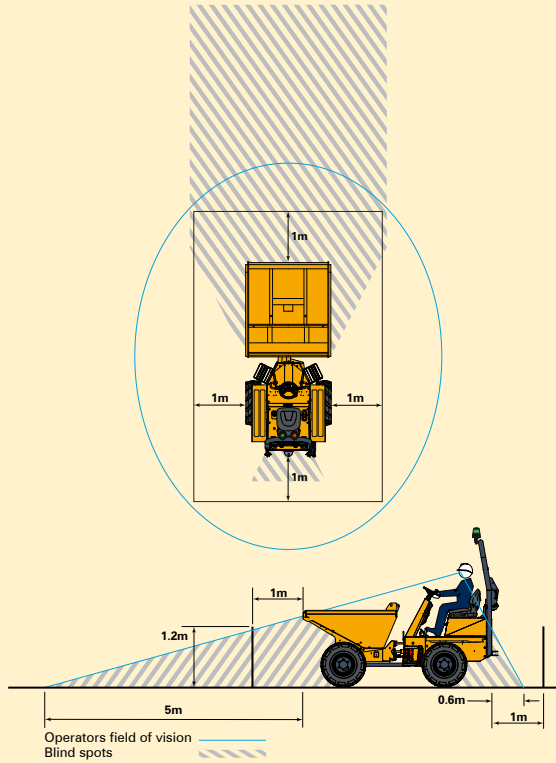

Mach 2073

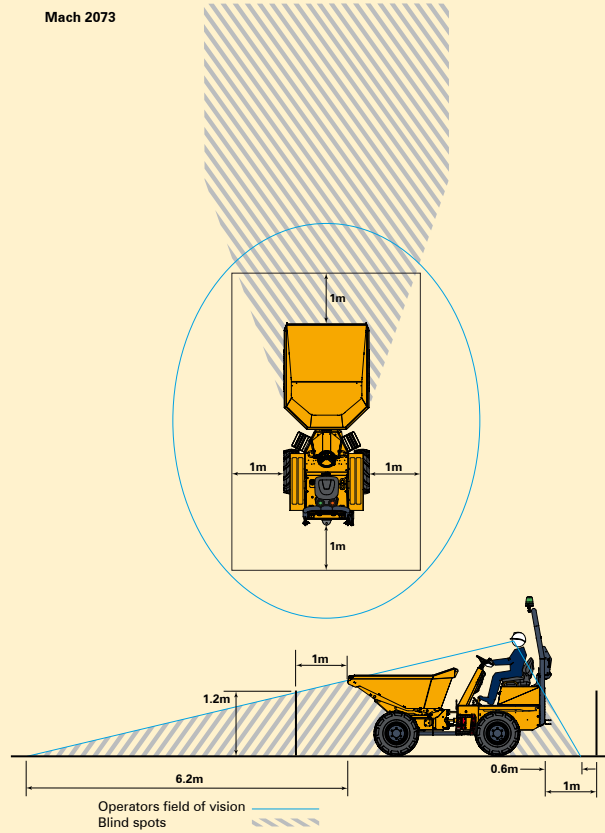

Attention! Section 3 correct and incorrect working practices

3



WARNING

HAZARDS OR UNSAFE PRACTICES WHICH COULD RESULT IN SEVERE PERSONAL INJURY OR DEATH

Thwaites

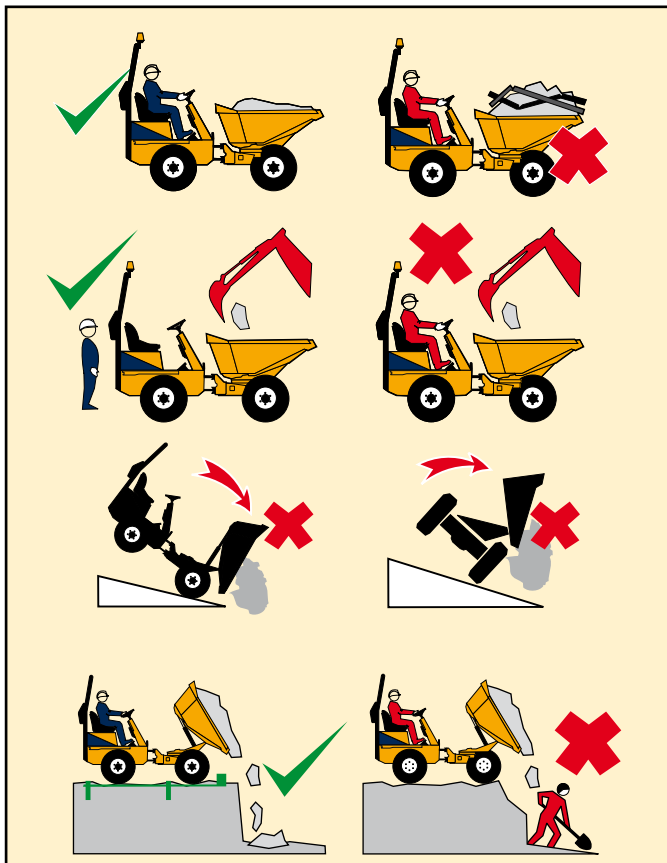

### LOADING THE MACHINE



**DO NOT** exceed the machine's rated capacity



Activate the hand brake, set drive to neutral, turn the engine off, disembark the machine, and stand clear



Clear any debris from controls



Ensure **SAFE STABLE LOW** load which allows good visibility



Reduce payload if materials being carried are not free flowing



### UNLOADING THE MACHINE



Use **STOPBOARDS** and **SUPPORT** walls on trenches



**DO NOT** tip skip if load is sticking



**DO NOT** discharge load when working on sloping ground



Attention! Section 3 correct and incorrect working practices

3



WARNING

HAZARDS OR UNSAFE PRACTICES WHICH COULD RESULT IN SEVERE PERSONAL INJURY OR DEATH

Thwaites

DRIVING

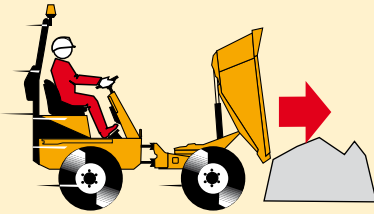

DO NOT drive with the skip tipped (bulldozing)

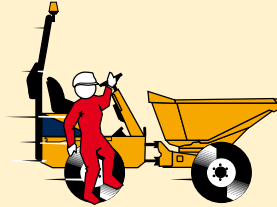

NEVER dismount from a moving machine

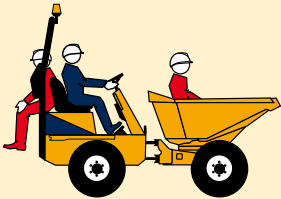

DO NOT carry passengers

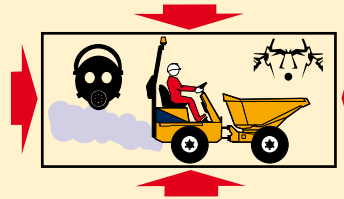

Avoid confined work areas - exhaust fumes and noise can be a hazard



Site hazards to avoid: adverse weather conditions; icy surfaces; people

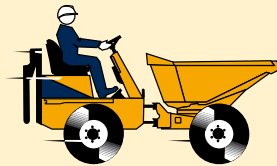

DO NOT operate with the ROPS frame folded down



Attention! Section 3 correct and incorrect working practices

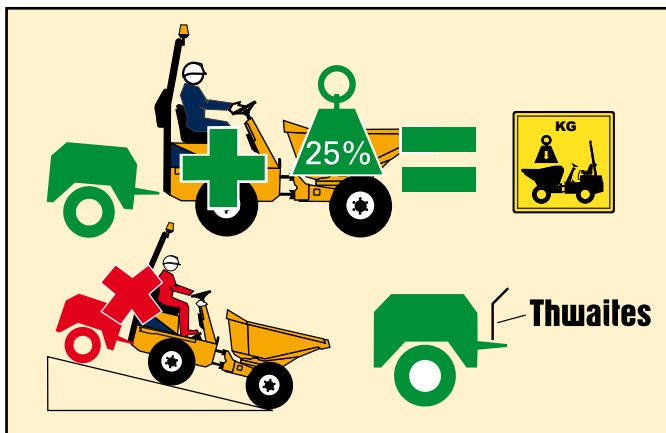

**3****WARNING****HAZARDS OR UNSAFE PRACTICES WHICH COULD RESULT IN SEVERE PERSONAL INJURY OR DEATH****Thwaites****TOWING A TRAILER**

Place ballast load in skip. This load should be a minimum of 25% of the machine's rated payload

Gross weight to be towed plus the ballast load **MUST NOT** exceed rated payload of machine.**DO NOT** exceed maximum tow bar pull or vertical load

Towing must not be carried out on sloping ground

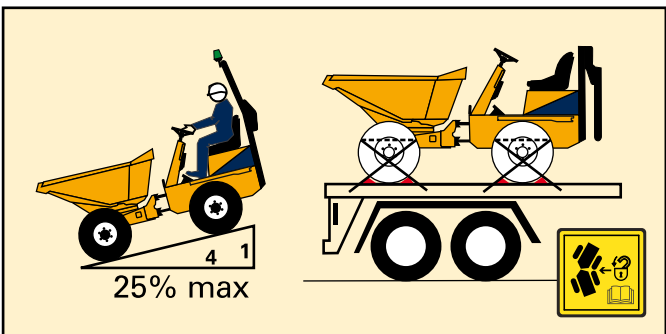

Always use Thwaites-approved towing pin

**TRANSPORTATION**

Reverse machine slowly onto a suitable trailer

**DO NOT** drive the machine forwards when loading

- Apply hand brake
- Stop engine
- Chock wheels (*To prevent movement*)
- Engage chassis locking bar
- Secure to trailer
- Ensure legal load (*Height/weight*)

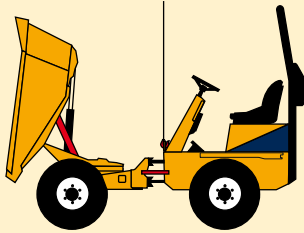

Attention! Section  correct and incorrect working practices

**3****CAUTION**HAZARDS OR UNSAFE PRACTICES WHICH **COULD** RESULT IN MINOR PERSONAL INJURY OR PRODUCT OR PROPERTY DAMAGE**Thwaites****LIFTING**

Tip skip fully forward  
 Engage skip safety prop  
 Engage chassis locking bar  
 Lift using centre eye provided

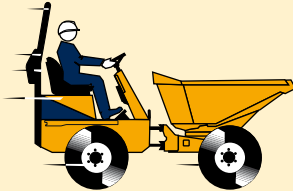
**HAND BRAKE**

**DO NOT** apply hand brake if machine is moving (except in an emergency)

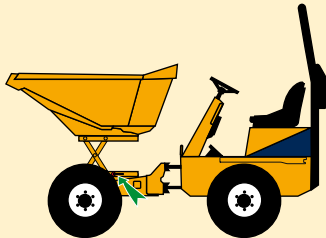
**SCISSOR LIFT**

Insert locking pin when working beneath skip

Attention! Section

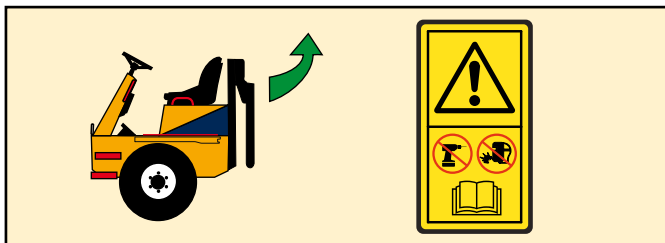

correct and incorrect working practices

**3****CAUTION**HAZARDS OR UNSAFE PRACTICES WHICH **COULD** RESULT IN MINOR PERSONAL INJURY OR PRODUCT OR PROPERTY DAMAGE**Thwaites****HINGED ROPS**

Use grab handles, tread grips (if fitted) and steps when standing on the machine to lower the ROPS frame.



Avoid wet surfaces.

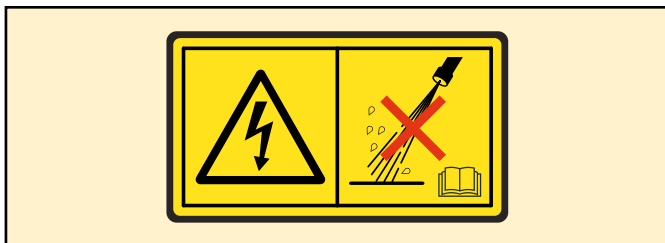

Never modify structure

**ELECTRICAL SYSTEM DAMAGE**When pressure washing the machine avoid electrical system or component damage. **DO NOT** aim directly at electrical components housed beneath the engine cover or located within the instrument panel.*Attention! Section**correct and incorrect working practices*

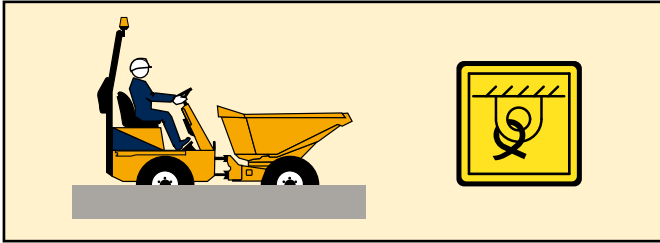
**3****CAUTION**HAZARDS OR UNSAFE PRACTICES WHICH **COULD** RESULT IN MINOR PERSONAL INJURY OR PRODUCT OR PROPERTY DAMAGE**Thwaites****MACHINE RECOVERY****Towing procedure**

Ensure towing straps or chains are suitable for the machine to be towed. (1.5 time more than the gross weight.)

Tow the machine using the front tie down points or around the rear axle.

Tow the machine in neutral with the engine running.

**Moving a disabled machine**

Towing or pushing a disabled machine can only be done after the following has been carried out.

- Handbrake emergency release procedure.

**WARNING**

If rear axle brakes are not disengaged damage will be caused to transmission and hydraulics.

Attention! Section

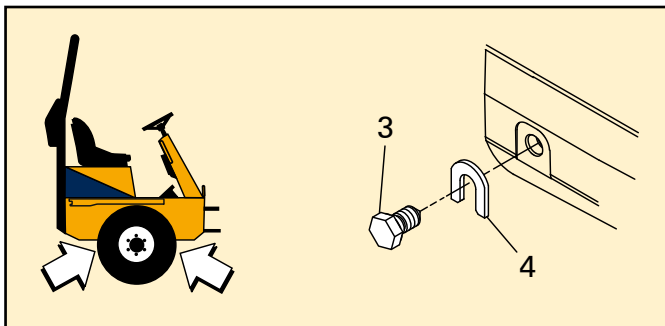

correct and incorrect working practices

**3****CAUTION**HAZARDS OR UNSAFE PRACTICES WHICH **COULD** RESULT IN MINOR PERSONAL INJURY OR PRODUCT OR PROPERTY DAMAGE**Thwaites****To release the fail safe brake:**

- Loosen the two screws (3) on the axle housing and remove the spacers (4).
- Tighten the screws (3) by hand until they are in contact the internal pusher plate. After tightening the screws, alternatively, for  $\frac{1}{4}$  of turn on each side, with a wrench until they are completely tightened.

**RESET OF FAILS SAFE BRAKE FUNCTION**



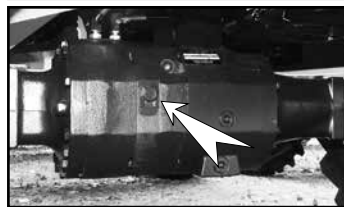
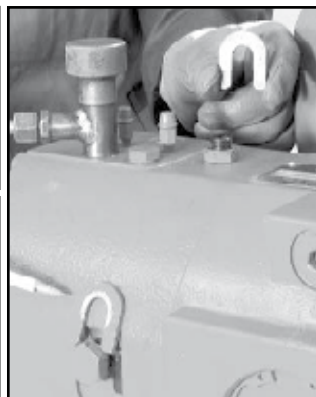
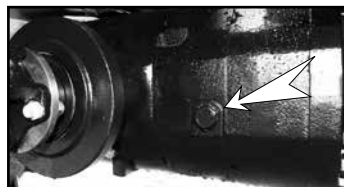



- Loosen again the screws (3) alternatively for  $\frac{1}{4}$  of turn on each side and fit in the spacer (4) between the screw head and the axle cover.
- Tighten the screws (3) completely against the spacer with torque of 95 - 115 N·m.

**TOWING THE MACHINE**

- The maximum towing speed of 2 km/h should not be exceeded.
- The towing distance should not exceed 1 km.

*Attention! Section**correct and incorrect working practices*

# 4 Troubleshooting

Problem	Reason	Solution
Engine will not start	Isolator switch OFF Clutch not depressed Battery voltage too low Faulty fuel supply Electrical stop on fuel pump defective Circuit breaker tripped Seat belt not fastened (if green beacon fitted)	Switch on Depress clutch pedal Check battery and connections Check fuel level and connections Check connections Rectify electrical fault and reset (push to reset) Fasten seat belt
Complete loss of electrical functions	Maxi fuse blown	Rectify electrical fault and replace fuse
Starter motor will not operate	Faulty battery	Replace
Maxi fuse blown	Faulty starter motor/solenoid (Current drawn by solenoid exceeds 25A) Short circuit on main feed or starter solenoid cables	Replace starter motor/solenoid and maxi fuse (only replace with a 30 amp fuse) locate and repair
Engine stops soon after start-up	Blocked fuel or air filter Air in fuel system	Replace fuel or air filter Check fuel line connections
Black engine smoke	Air filter clogged (air filter indicator is red) Fuel system defect Wrong fuel	Replace or clean air filter Contact Thwaites dealer Replace fuel and filter
 ● Engine oil pressure  ● High engine temperature  ● Irregular alternator  ● Transmission oil temperature  ● Transmission oil pressure  ● Low brake oil Warning buzzer sounds	Low oil level  Radiator choked Low coolant level  Defective or loose alternator belt  Oil cooler choked Over/under filled with oil  Low transmission fluid level  Check oil level/leaks  Hand brake ON	Top up engine oil  Clean radiator Top up coolant  Adjust, or, if necessary, replace alternator belt  Clean oil cooler Correct oil level  Top up transmission fluid  Top up brake oil  Release hand brake

Always check panel warning lights, tripped circuit breakers or blown maxi fuse

# 4 Powerswivel and Hi swivel – data chart

**Thwaites**

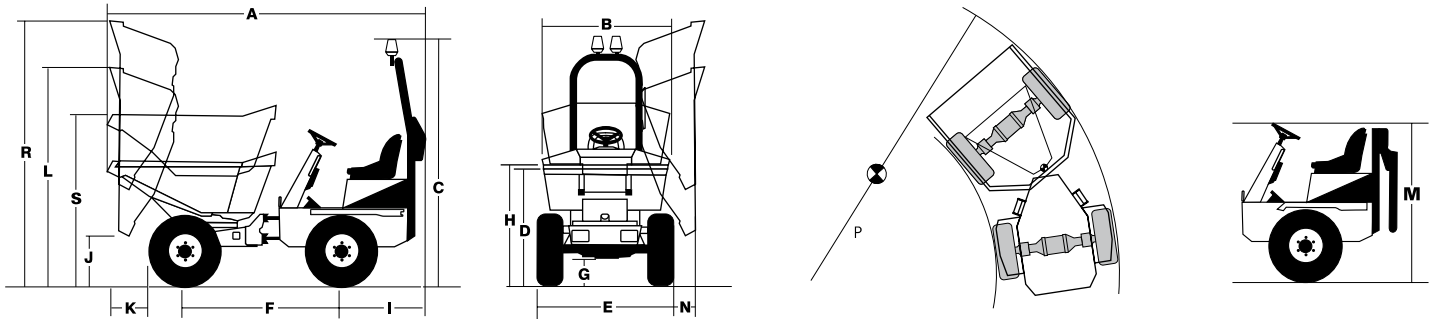



Dimensions (mm)	2T	2T Hi Sw	3T	Weight (Kg)	2T	2T Hi Sw	3T	Noise
A. Length.....	3726.....	3726.....	3934	<b>Unladen</b>				Airborne (10m) 
B. Width.....	1471.....	1471.....	1638	Front axle.....	700.....	920.....	770	
C. Height (ROPS & Beacon).....	3053.....	3053.....	3180	Rear axle.....	1300.....	1340.....	1350	Operator 
D. Skip lip height.....	1356.....	1479.....	1456	Total.....	2000.....	2260.....	2120	
E. Width over tyres.....	1488.....	1488.....	1650	<b>Rated payload (including driver at 80 kg)</b>				
F. Wheelbase.....	1850.....	1850.....	1950	Laden.....	2000.....	2000.....	3000	
G. Ground clearance.....	282.....	282.....	337	Front axle.....	2510.....	2760.....	3460	
H. Skip load height.....	1416.....	1536.....	1581	Rear axle.....	1570.....	1580.....	1740	
I. Axle to rear.....	1042.....	1042.....	1042	Total.....	4080.....	4340.....	5200	
J. Tipping ground clearance.....	728.....	1236.....	751	<b>Towbar (Max)</b>				
K. Tipping tyre clearance.....	475.....	525.....	546	Pull load.....	1500.....	1500.....	2250	
L. Height tipped (skip).....	2671.....	3152.....	2841	Vertical load.....	375.....	375.....	375	
M. Height (ROPS folded).....	1926.....	1926.....	1981	<b>Tyre Pressure</b>				
N. Tipping side clearance.....	189.....	239.....	388	Bar (psi) Front.....	3.5(51)....	3.5(51)....	3.6(52)	
P. Tyre clearance diameter (m).....	7.4.....	7.4.....	9.2	Rear.....	2.3(33)....	2.3(33)....	2.0(29)	
R. Max height tipped (raised skip).....			3642.....					
T. Skip lip height (raised skip).....			1971.....					

Typical vibration levels - whole body 0.7 - 0.8 m/s<sup>2</sup>. Hand/arm less than 2.5 m/s<sup>2</sup>.

# 4 Forward tip – data chart

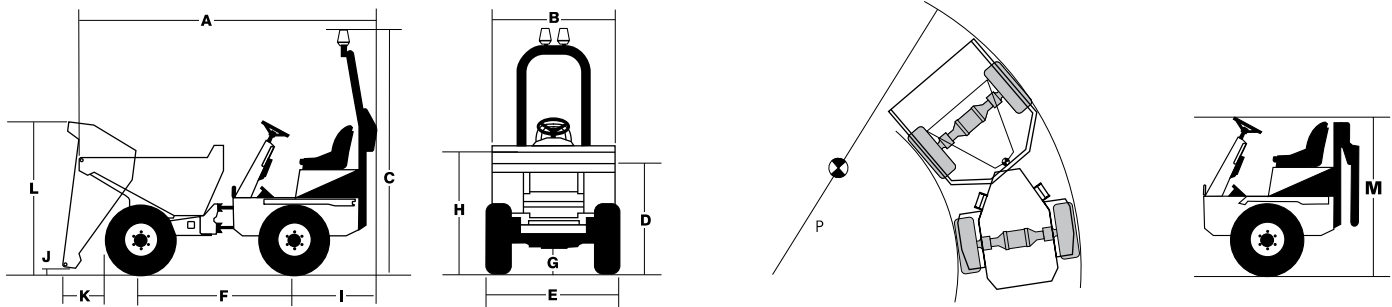
# Thwaites



Dimensions (mm)	2T	3T	Weight (Kg)	2T	3T	Noise
A. Length .....	3603	3785	<b>Unladen</b>			Airborne (10m) 
B. Width.....	1490	1650	Front axle .....	580	620	
C. Height (ROPS & Beacon) .....	3053	3108	Rear axle .....	1300	1350	Operator 
D. Bucket lip height.....	1346	1381	Total .....	1880	1970	
E. Width over tyres.....	1488	1650	<b>Rated payload (including driver at 80 kg)</b>			
F. Wheelbase .....	1850	1950	Laden .....	2000	3000	
G. Ground clearance.....	282	337	Front axle.....	2290	3140	
H. Skip load height.....	1431	1524	Rear axle .....	1670	1910	
I. Axle to rear .....	1042	1042	Total .....	3960	5050	
J. Tipping ground clearance.....	278	321	<b>Towbar (Max)</b>			
K. Tipping tyre clearance.....	594	603	Pull load .....	1500	2250	
L. Height tipped (skip).....	2001	2131	Vertical load.....	375	375	
M. Height (ROPS folded) .....	1926	1981	<b>Tyre Pressure</b>			
P. Tyre clearance diameter (m).....	7.4	9.2	Bar (psi) Front .....	3.5 (51)	3.6(52)	
			Rear .....	2.3 (33)	2.0(29)	

Typical vibration levels - whole body 0.7 - 0.8 m/s<sup>2</sup>. Hand/arm less than 2.5 m/s<sup>2</sup>.



# 4 Maintenance Tasks

Thwaites

## Safe Working Practice:

Before lubrication and maintenance tasks:

- Machine must be on firm level ground.
- Apply parking brake.
- Stop engine and remove ignition key.
- Isolate the battery (See section 1 - Battery isolator)
- Allow engine to cool.
- Place FNR/gear lever in neutral.
- Fit chassis locking bar
- Chock the wheels
- Prop bucket when working beneath
- Lock skip safety prop(s)



Refer to service manual for further reference



## WARNING - FUEL HANDLING

- Diesel fuel is FLAMMABLE.
- Never refuel or service the fuel system while smoking or near naked flames.
- Never refuel the machine while the engine is running.

## Recommended maintenance tasks:

- Turn ignition switch '**ON**' without starting engine, and wait 2 seconds for all warning lamps to turn off.
- Note any lamp that remains lit and correct system fault identified before operating the machine.
- Turn ignition switch '**OFF**'.

## Daily (10 hour) maintenance check list:

- Diesel fuel level
- Engine oil level
- Engine coolant level
- Hydraulic tank oil level
- Hand brake function
- Foot brake resistance
- Steering wheel and column condition
- Tyre pressure
- Air cleaner indicator

## Weekly (50 hour) maintenance check list:

- Wheel nut torque
- Brake oil level
- Fan belt
- Sufficient lubricant in all grease points

## First (100 hours) - New machine - change:

- Axle oil (Refer to service manual for procedures)

## 4 Daily (10 Hour) maintenance checks

**Thwaites**

### Diesel fuel tank volumes

- Check fuel level on gauge (Fig 1, A) and fill fuel tank through filler cap (Fig 1, B) with required amount of diesel, noting MAX/MIN volumes and fuel quality:

Maximum	24.5 litres
Gauge indicates empty	3.0 litres

### Engine oil level

- Pull out lubricating oil dipstick and wipe clean (Fig 2, A)
- Insert lubricating oil dipstick as far as it will go.
- Pull out lubricating oil dipstick, ensure oil level is between the MIN and MAX markers (Fig 3).
- Top up to MAX marker if necessary, through oil filler cap, using recommended oil. Machine initially filled with SAE15W40 (Fig 2, B).

### CAUTION - COMPLIANT FUEL USAGE

To avoid fuel system damage and to satisfy exhaust gas legislation, fuel used in this machine **MUST** comply with one of the following approved low sulphur diesel specifications. DIN 51628, EN 590 or BS 2869 (Sulphur <10 mg/kg)

### CAUTION - HOT FLUIDS

Check oil levels with machine on firm, level ground and with the machine cooled down.

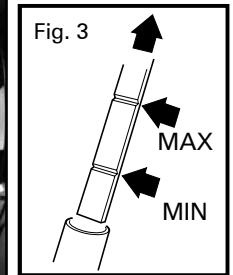
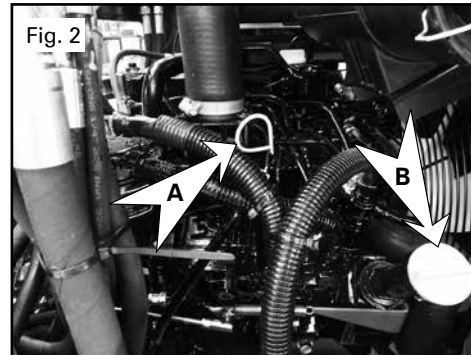
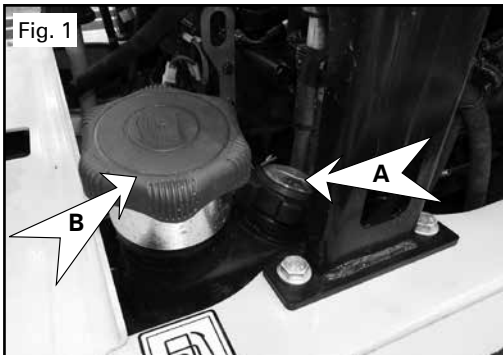

# 4 Daily (10 Hour) maintenance checks

**Thwaites**

## Engine coolant level

- View level of coolant in expansion bottle
- The coolant level must always be between the MIN and MAX marks (Fig 1).
- Top up at radiator cap if necessary (Fig 2).

 Use the correct concentration of coolant. Machine initially filled with water plus 50% antifreeze to BS.6580.

## Hydraulic oil level

- With oil cold, ensure rams are in correct position by lowered bucket, turning steering to full left lock and if power swivel, turn bucket into the straight ahead position.
- Level is correct when visible in sight gauge (Fig 3).
- If no oil can be seen top up as required using approved hydraulic oil to (HV46) through filler cap (Fig 4).
- Do not overfill above sight gauge.



### WARNING - HOT FLUID

**DO NOT** attempt to remove the radiator cap until system has cooled down to avoid serious scalding.



### CAUTION

It is imperative that hydraulic oil is clean to avoid damage to hydraulic components.

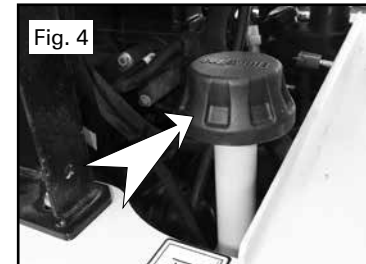
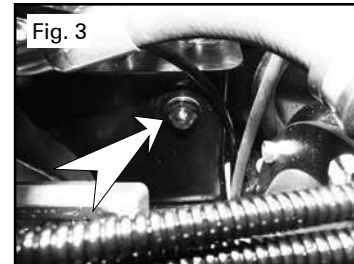
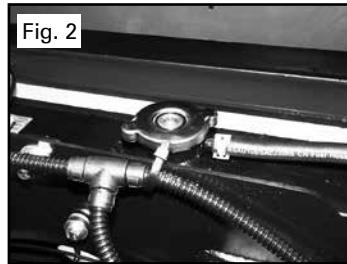

## 4 Daily (10 Hour) maintenance checks

**Thwaites**

### Check brake functions

*Note: Refer to section 1 of this manual for control layout.*

### Hand Brake

No regular maintenance is required. Check hoses for leaks.



If leaks or damage is found do not operate the machine until the fault has been corrected.

### Foot brake (Primary)

From the drivers seat, with your right foot press the brake pedal until resistance to movement is felt.

The pedal position should be no more than half way to the end of the slot in the floor plate.



If pedal travel is excessive do not operate the machine until the fault has been corrected.

### Steering wheel / column

Check the steering wheel for signs of damage (misshapen or broken). Hold the steering wheel push and pull to check for excessive movement in the steering column (Fig 1).



If either is found do not operate the machine until the fault has been corrected.



### Check wheels and tyres

Check tyre pressures (Refer to data chart in section 4)

## 4 Daily (10 Hour) maintenance checks

Thwaites

### Check Air Cleaner Indicator

When window (Fig. 1) indicates RED, replace or clean filter as follows:

- Pull release clip (Fig. 2) and remove the end cup.
- Twist to remove primary element and secondary element (Fig. 3).
- Clean inside body.
- Refit or replace elements twist to ensure correct seating.
- Refit the end cup and secure clip.



DO NOT run engine with air cleaner removed.

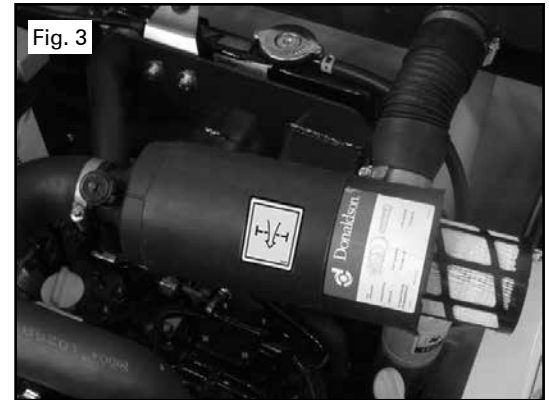
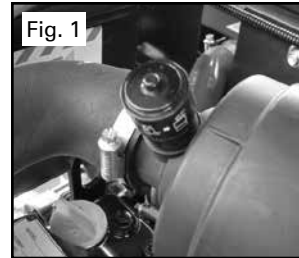

# 4 Weekly (50 Hour) maintenance checks

## Check wheel nut torque

Check wheel nuts are in position and tight (330Nm)

## Check Brake Oil Level

Brake master cylinder reservoir must be checked regularly. If oil level is low check system for leaks at all joints and pipes for damage. Top up to correct level with approved oil (Fig. 1). Should brake reservoir need frequent additions of oil, machine **must not be used**. A thorough check of brake system must be carried out.

**Note:** Before removing filler cap clean area carefully to prevent contamination.

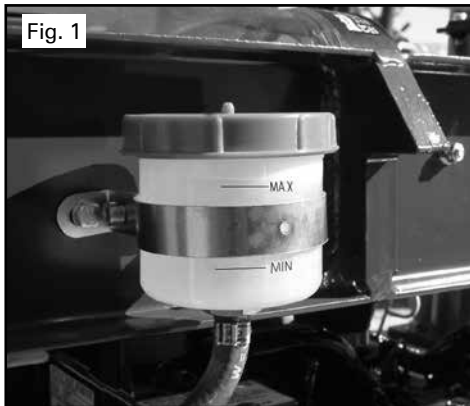

## Check Fan/Drivebelt Tension

- Isolate the battery (Fig. 2).
- Belt should have 10-15 mm of movement for correct tension (Fig. 3). (Refer to service manual for adjustment procedure)

### WARNING

Isolate the battery before servicing, or making adjustments to the electrical system.

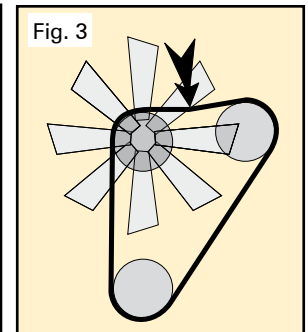
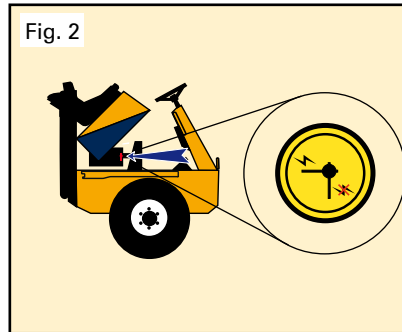

# 4 Weekly (50 Hour) maintenance checks

Thwaites

## Lubricate all grease points:

Apply grease to the following points provided around the machine to improve operation of moving parts:

1. Steering cylinder
2. Tipping cylinder
3. Kinglink assembly
4. Skip pivot pins
5. Propshafts
6. Engine cover hinges
7. Folding ROPS frame pins
8. Slew cylinders (Powerswivel Only)
9. Slew Ring (Powerswivel Only)
10. Central skip lock (Powerswivel Only)
11. Scissor frame pivot pins (Hi Swivel Only)

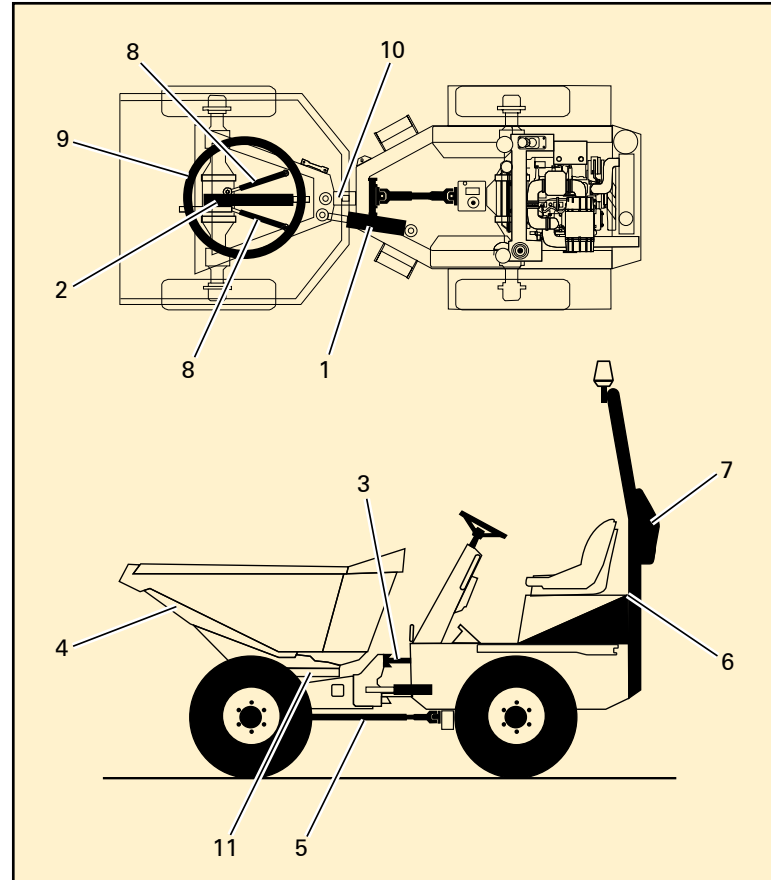

# **Thwaites**

Normal service intervals:  
10hrs, 50hrs, (first 100hrs), 250hrs, 500hrs, 1000hrs, 2000hrs

Please refer to the Thwaites service manual for further maintenance information.

*We reserve the right to change all specifications without prior notice.*

**[www.thwaitesdumpers.co.uk](http://www.thwaitesdumpers.co.uk)**