

INSTRUCTION MANUAL

Tandem roller HD 10 / HD 12

H230 Series	4097 Valid from serial no.
25.05.2021 Date of first issue	
2981339 Order number	en Language





Publisher	HAMM AG Hammstraße 1 95643 Tirschenreuth Germany Phone: +49 (0) 96 31 / 80-0 www.hamm.eu
Name of the document	2981339_01_BAL_HD10_HD12_H230_en Original instruction manual
SMC document version	1621471999440_H230_01
Date of first issue	25.05.2021
Date of change	23.08.2021
Copyright	© HAMM AG 2021

Transmittal and reproduction of this document as well as utilization of its contents and communication thereof to others without express authorization are prohibited. Violations will cause indemnities. All rights regarding patent, utility model and design registration are reserved.



This instruction manual is valid for the following roller types:

TANDEM ROLLER HD 10 VV
 HD 10 VO
 HD 12 VV
 HD 12 VO

COMBINATION ROLLER HD 10 VT
 HD 12 VT

ROLLER DRUMS

	front	rear
VV	Vibration	Vibration
VO	Vibration	Oscillation
VT	Vibration	Tyres

TABLE OF CONTENTS

1	General.....	10
1.00	Preface.....	10
1.00.01	Preface to the instruction manual.....	10
1.00.02	Product information.....	10
1.00.03	Guarantee.....	11
1.00.04	Modifications/reservations.....	11
1.00.05	Packaging and storage.....	11
1.00.06	Signs and symbols.....	11
1.00.07	Explanation of Abbreviations.....	12
1.00.08	Warning notes.....	13
1.01	Documentation.....	15
1.02	Use.....	16
1.02.01	Intended use.....	16
1.02.02	Abnormal use.....	16
1.02.03	Residual risks.....	17
1.02.04	Climatic conditions.....	18
1.03	Environmental protection.....	19
1.04	Disposal.....	20
1.05	EC conformity.....	21
1.06	Type plate.....	23
1.07	Noise and vibration requirements.....	28
1.08	Personnel.....	29
1.08.01	Qualification and duties.....	29
1.09	General safety instructions.....	31
1.10	Driving on public roads.....	32
1.11	Danger zone.....	33
2	Description.....	34
2.00	Information on the machine.....	34
2.00.01	Technical characteristics.....	34
2.00.02	List of auxiliary equipment.....	34



2.01	General view of machine.....	36
2.01.01	Chassis/safety devices.....	36
2.01.02	Stickers on the machine.....	36
2.01.03	ROPS.....	42
2.01.04	Consumable fill holes.....	43
2.02	Control stand.....	44
2.02.01	Seat console.....	44
2.02.02	Operating station controls.....	45
2.02.03	Steering column.....	45
2.02.04	Control panel.....	46
2.02.05	Drive lever.....	47
2.03	Drive unit/diesel engine.....	48
2.04	Hydraulic oil supply.....	50
2.05	Electrical system.....	51
2.06	Transmission.....	52
2.07	Steering system.....	53
2.08	Water system.....	54
2.08.01	Water sprinkling system.....	54
2.08.02	Additive sprinkling.....	54
2.09	Dynamic compaction system.....	55
3	Operation.....	56
3.00	Important information about operating the machine.....	56
3.01	Before loading/transporting/commissioning.....	59
3.01.01	Safety strut.....	59
3.02	Loading and transporting.....	61
3.03	Functional tests before starting work.....	68
3.04	Access to the machine.....	69
3.04.01	Access to the operator's platform.....	69
3.05	Adjust driver's seat.....	70
3.06	Using safety belt.....	73
3.07	Open and close engine hood.....	74
3.08	On-board electrical system/battery isolation switch.....	75
3.09	Switching the electrical system on and off.....	76
3.10	Switching the signal horn and lighting on and off.....	77

3.11	Starting the machine.....	79
3.12	Driving.....	81
3.12.01	Seat contact switch.....	81
3.12.02	Adjusting the engine speed.....	82
3.13	Driving in normal operation.....	83
3.14	Stopping the machine in normal operation.....	85
3.15	Machine is stopped in the EMERGENCY STOP state.....	86
3.16	Stopping the machine because of a fault.....	88
3.17	Driving with the dynamic compaction system.....	90
3.17.01	Switching the compaction system on and off.....	91
3.18	Driving with water sprinkling system.....	93
3.19	Driving with additive sprinkling system.....	95
3.20	Track offset.....	96
3.21	Adjusting scrapers.....	98
3.21.01	Rigid roller drum scraper.....	98
3.21.02	Upper folding roller drum scraper.....	98
3.21.03	Lower folding roller drum scraper.....	99
3.21.04	Scraper tyres.....	99
3.22	Operation monitoring.....	101
3.22.01	Control panel – fill level control indicator.....	103
3.22.02	Control panel – info display/system info.....	104
3.23	Switching diesel engine off.....	105
3.24	Shutting down and leaving the machine safely.....	106
3.25	Towing the machine.....	107
3.25.01	Preparing the machine for towing.....	108
3.25.02	Depressurize the hydraulic system.....	109
3.25.03	Releasing spring-operated brake.....	109
3.25.04	After towing/before repair.....	110
3.26	Start with jump leads.....	111
3.27	Shutting down.....	113
3.27.01	Temporarily shutting down the machine and starting it up again.....	113
3.27.02	Permanently shutting down and disposing of the machine.....	114



4	Maintenance.....	116
4.00	General maintenance instructions.....	116
4.00.01	Important information about maintenance works.....	116
4.00.02	Running-in instructions.....	119
4.00.03	Maintenance overview.....	121
4.00.04	Required maintenance parts.....	123
4.00.05	Welding work on the machine.....	124
4.01	Chassis/safety devices.....	126
4.01.01	Basic maintenance work.....	126
4.01.02	Checking and replacing steps/slip-resistant surface.....	126
4.01.03	Checking that the parking brake is working properly.....	127
4.01.04	Checking that the seat contact switch is working properly.....	127
4.01.05	Checking the EMERGENCY STOP function.....	128
4.02	Control stand.....	130
4.02.01	Checking the drive lever function.....	130
4.03	Drive unit/diesel engine.....	131
4.03.01	Lubricating oil change intervals.....	132
4.03.02	Maintenance points at the diesel engine when changing oil.....	132
4.03.03	Fuel prefilter.....	133
4.03.04	Check and clean the dust discharge valve at the air filter.....	135
4.03.05	Check the air filter.....	135
4.03.06	Replacing air filter cartridge.....	136
4.03.07	Replacing the safety cartridge at the air filter.....	136
4.03.08	Checking/cleaning radiator.....	137
4.03.09	Checking coolant fill level.....	138
4.03.10	Changing coolant.....	139
4.04	Hydraulic oil supply.....	141
4.04.01	Checking hydraulic oil level.....	141
4.04.02	Changing hydraulic oil and ventilation filter.....	142
4.04.03	Replacing filter insert of pressure filter for hydraulic system.....	143
4.05	Electrical system.....	144
4.05.01	Starter battery.....	144

4.06	Transmission.....	147
4.06.01	Checking roller drum/tyre scraper.....	147
4.06.02	Cleaning roller drum/tyre scraper.....	147
4.06.03	Replacing/adjusting the roller drum scraper.....	147
4.06.04	Replacing/adjusting tyre scrapers.....	148
4.06.05	Lubricate the scraper stop lever.....	149
4.06.06	Check that wheel nuts/wheel bolt connections are tight.....	150
4.06.07	Checking air pressure in the tyres.....	150
4.06.08	Changing the tyres.....	151
4.07	Steering system.....	154
4.07.01	Lubricating pivoted bearing.....	154
4.07.02	Lubricating the steering cylinder bolts.....	154
4.08	Water sprinkling.....	156
4.08.01	Checking the fill level.....	156
4.08.02	Checking the spray nozzles.....	156
4.08.03	Cleaning sprinkler nozzles.....	158
4.08.04	Cleaning filter for water sprinkling.....	158
4.08.05	Emptying and cleaning the water sprinkling system.....	159
4.08.06	Emptying and cleaning additive sprinkling system.....	160
4.09	Dynamic compaction system.....	162
4.09.01	Checking damping elements.....	162
5	Tables.....	163
5.00	Technical data.....	163
5.00.01	Engine oil.....	163
5.00.02	Fuel.....	165
5.00.03	Cooling liquid (coolant).....	166
5.00.04	Hydraulic oil (mineral oil).....	167
5.00.05	Biological hydraulic oil.....	169
5.00.06	Wirtgen Group Asphalt Anti Stick.....	170
5.00.07	Overview of lubricant details.....	171
5.00.08	Starting torques.....	172
5.00.09	Wirtgen Group Lubricants.....	173



5.01	Technical data.....	177
5.01.01	HD 10 VV.....	177
5.01.02	HD 10 VO.....	179
5.01.03	HD 10 VT.....	181
5.01.04	HD 12 VV.....	183
5.01.05	HD 12 VO.....	185
5.01.06	HD 12 VT.....	187
5.02	Dimension sheet.....	189
5.02.01	HD 10 (VV, VO).....	189
5.02.02	HD 10 VT.....	189
5.02.03	HD 12 (VV, VO).....	190
5.02.04	HD 12 VT.....	190
5.03	Fuses.....	191
5.03.01	Engine compartment.....	191
5.03.02	Steering column.....	192
5.03.03	Dashboard/control panel.....	192
5.04	Diagnostic code.....	193
6	Auxiliary equipment.....	194
6.00	Roll-over protection structure (ROPS).....	195
6.01	Falling-object protective structure (FOPS).....	197
6.02	Rotating beacon.....	198
6.02.01	Overview.....	198
6.02.02	Description.....	198
6.02.03	Mounting/Dismounting.....	198
6.02.04	Operation.....	200
6.02.05	Maintenance.....	201
6.03	Anti-freeze filling system for water sprinkling.....	202
6.03.01	Overview.....	202
6.03.02	Description.....	202
6.03.03	Operation.....	202

1 GENERAL



When working at the machine please always adhere to the instructions given in your Safety instructions!

1.00 Preface

1.00.01 Preface to the instruction manual

This chapter contains important instructions for the operating personnel on how to operate the machine and to use this instruction manual.

Read the instruction manual carefully and get to know the machine.

Following the instruction manual:

- Helps to avoid risks.
- Helps to avoid malfunctions due to improper use.
- Increases the reliability when working on the construction site.
- Increases the service life.
- Reduces maintenance costs and downtimes.

Please note:

- the instruction manual.
- the safety manual.
- supplementary information.
- regulations and provisions applying at the building site (e.g. accident prevention regulations).

Maintain and care the diesel engine according to the instructions for the motor. Observe the safety instructions.

1.00.02 Product information

You have received a quality product. All the components of this machine have been carefully inspected and tested. Therefore they comply with the quality that you expect.

The reliability of the machine is preserved through correct use and careful maintenance. Only use the specified operating supply items and the original HAMM spare parts of the machine manufacturer.

Our representations will help you to keep your roller in perfect operating condition.

After the warranty period, our representatives will also assist you with advice and service. They will supply you with our original spare parts which do not only meet the technical requirements but also ensure exchangeability and quality.

The instruction manual contains

- safety instructions,
- operating instructions and
- maintenance instructions.

They are intended to be used by the operating personnel. Thus, keep the instruction manual always at hand!

1.00.03 Guarantee

Warranty claims can only be accepted:

- if you operate the machine correctly.
- if you use original spare parts.
- if you use the specified operating supply items.
- if you install the accessory equipment that the manufacturer has approved.
- if you maintain the machine as prescribed.
- if you use the machine how described in the instruction manual.

In all other cases, the warranty is excluded.

1.00.04 Modifications/reservations

The instruction manual describes the current version of the machine. But we may not exclude errors completely. We can modify the product and its operation so that we do not lose our technological lead. We assume no liability for malfunctions, downtimes and resulting damage.

1.00.05 Packaging and storage

We pack the machine carefully for shipment. Please check both packaging and the machine for any damage to the machine upon receipt of the goods. The machines must not be operated if they are damaged. Only use undamaged cables and plug connections.

Please contact your supplier if the machine damaged.

After unpacking, protect the machine from moisture and contamination if it is not going to be brought into operation immediately.

1.00.06 Signs and symbols

The signs and symbols used in this instruction manual are to help you use this instruction manual and the machine in a safe and fast manner.

Note



Informs about application hints and useful information.

Enumeration

- Unordered lists list various possibilities.

Operating step

- ▶ Action steps describe the activities required to use the machine correctly and safely.

Result

- ✓ Describes the result of a sequence of action steps.

Directions

Information on directions always describe to the directions of the machine driving forwards. Possible is information on directions like:

- left or right
- front or rear

Cross-references

Cross-references allow you to quickly find certain sections in the operating manual that provide additional important information. The cross-reference provides the page for the relevant section.

Example: (see "Hydraulic oil supply", page 176)

Positioning in illustrations

Figures are labelled with numbers. Item lines connect the correct items in the figure with the numbers. The numbers only annotate the items for the text section to which the figure belongs. The numbering starts anew for each figure. In descriptive text, these numbers are in square brackets. So you can obtain important and additional information quickly. The end of the item line is a point or an arrow. A point marks a visible element in the figure. An arrow marks an invisible element, which lies in the direction of the arrow.

If necessary, figures have legends to provide the information required.

Example

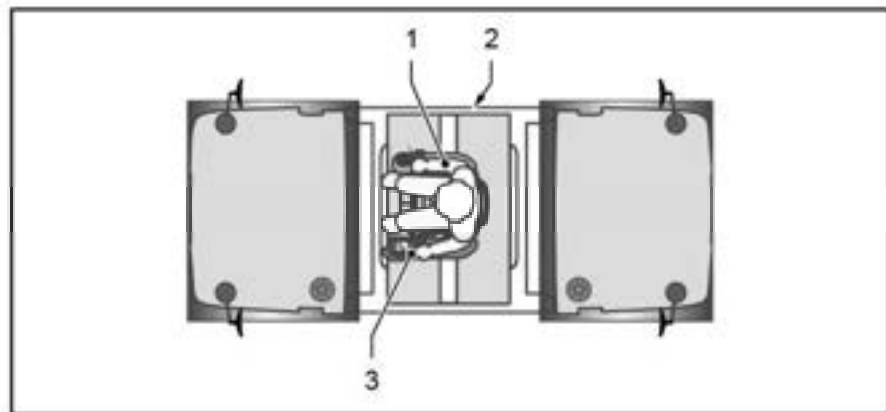

[1]	Driver	[2]	Engine compartment
[3]	Drive lever		

Descriptive text

You use the drive lever [3] to determine the direction of travel and driving speed.

1.00.07 Explanation of Abbreviations

Abbreviations are used for machine elements and processes in this instruction manual

Abbreviations that are not in the list are explained at the first positions in the text that they occur in the instruction manual.

Abbreviation	Meaning
DOC	Diesel oxidation catalyst Exhaust gas after-treatment system
DPF	Diesel Particulate Filter

Abbreviation	Meaning
	<i>Exhaust gas after-treatment system</i>
FOPS	Falling Object Protective Structure <i>Protective structures for the driver's cabin and driver's cab to protect against falling objects</i>
HMV	HAMM Measurement Value <i>Measured value for HAMM compaction indicator</i>
RMV	Resonance Measurement Value <i>Measured value for the resonance behaviour of the compaction system</i>
ROPS	Roll Over Protective Structure <i>Roll-over protection structure for the driver's cabin and driver's cab</i>
SCR	Selective Catalytic Reduction <i>Exhaust gas after-treatment system</i>

1.00.08 Warning notes

Warning notices inform about sources of danger, and state risks and how to avoid them.

Always follow the instructions to avoid risks!



Warning notices always apply to the complete section of the instruction manual that they precede.

Signal words

The signal word indicates the particular seriousness of the danger to persons and machines, objects and the environment.

▲ DANGER

Indicates an immediate danger to persons.
If the danger is not averted, death or the most serious, irreversible injuries will ensue.

▲ WARNING

Indicates a possible danger to persons.
If it is not averted, death or the most serious, irreversible injuries could ensue.

▲ CAUTION

Indicates a possible danger to persons.
If this situation is not avoided, minor or light injuries may be caused.



NOTICE

Indicates a danger to machines, objects or the environment.
If it is not averted, material damage will ensue.



1.01 Documentation

This instruction manual is intended to make the operating personnel familiar with the basic work and activities on and with the machine.

The entire instruction manual consists of:

- Safety manual
- Instruction manual of the machine
- Instruction manual of the diesel engine
- If necessary, additional information (e. g. QR code)

This instruction manual must be kept on the machine at all times. Read this instruction manual carefully. Let someone explain to you the things that you do not understand. Until this has been done, do not carry out any work with or on the machine.

1.02 Use

1.02.01 Intended use

The machine represents state-of-the-art technology and complies with all valid safety regulations concerning its intended use at the time the machine was launched on the market.

When designing the machine it was not possible to avoid all possible foreseeable misuse or residual risks without restricting the machine's intended functionality.

The machine's intended use is:

- To pave roads and traffic areas.
- To ram and smooth loose earth, road bedding, pavement or similar ramable subgrade in layers.

Use the machine only on load-bearing soil.

Not capable of bearing are e.g. high fillings, batters, roadside ditches.

The machine may not be used in explosive areas, on landfill sites and in mining.

The machine is only used for commercial applications within fenced construction sites.

The machine must only be operated by authorized operating personnel and only if in proper technical condition and in accordance with this instruction manual.

All unintended use and/or all machine-related activities not described in this instruction manual is to be deemed as unauthorised misuse outside the legal limits of indemnity of the manufacturer.

1.02.02 Abnormal use

Any abnormal use or any misuse of the machine can cause serious personal injury and/or death and will void the manufacturer's warranty obligation, and the owner will bear the sole responsibility in this case.

Abnormal uses shall be deemed to include:

- Non-compliance with this instruction manual.
- Operating errors by operating personnel not qualified or not instructed.
- Conveyance of passengers.
- Leaving the driver's position during operation.
- Starting, using the machine outside the driver's position.
- Errors due to reflexive behaviour and/or choosing the easiest way.
- Operating the machine if it is not in a proper technical condition.
- Using the machine with improper ambient conditions (e.g. temperature, gradient, transverse gradient).



- Using the machine with the protective equipment removed.
- Spraying with high-pressure cleaners or fire extinguishing equipment.
- Towing trailing loads.
- Non-compliance with maintenance intervals.
- Omission of measurements and tests to detect damages early.
- Omission of replacing wear parts.
- In the case the spare parts used are no original spare parts.
- Omission of maintenance and repair work.
- Improper maintenance and repair work.
- Unauthorized modifications of the machine.

1.02.03 Residual risks

Residual risks have been analysed and evaluated prior to starting the construction and planning the machine. Existing residual risks are referred to in the documentation. However, the manufacturer cannot foresee all situations that may pose a risk in practice.

You can avoid existing residual risks if you comply with and implement the following instructions:

- Special warnings at the machine.
- General safety instructions in this instruction manual and in the safety instructions.
- Special warnings in this instruction manual.
- Instructions contained in the safety instructions.
- Operating instructions of the operator.

Danger of life/risk of personal injury when operating the machine due to:

- Misuse.
- Improper operation.
- Transport.
- Missing protective equipment.
- Defective and/or damaged components.
- Operation/usage by personnel not trained and/or instructed.

The machine may cause risk to the environment e.g. with:

- Improper operation.
- Operating supply items (lubricants etc.).
- Noise emission.

Property damage may occur at the machine e.g. with:

- Improper operation.
- Non-compliance with operating and maintenance instructions.
- Improper operating supply items.

Property damage may occur at further assets within the machine's operating area e.g. with:

- Improper operation.

Reduction in performance and/or the machine's functionality may occur at the machine e.g. with:

- Improper operation.
- Improper maintenance and/or repair work.
- Improper operating supply items.

1.02.04 Climatic conditions

The permissible ambient temperature range for using the machine is -20 °C (-4 °F) up to 55 °C (130 °F).

Operation outside this temperature range requires the express authorization of the manufacturer. Use under extreme climatic conditions places special demands on equipment and fuel.

▲WARNING

Explosion!

Severe injury and death due to burns and moving parts.

- Do not use aerosol start-up aid (e.g. ether).
- Do not use any liquids as start-up aid (e.g. alcohol).
- Adapt operating materials, such as oils and coolant, to the ambient temperature.
- Observe the instruction manuals for the battery and diesel engine.

Low ambient temperature **The diesel engine's starting behaviour and the machine's operation depend on:**

- The fuel used.
- The viscosity of the motor, gear and hydraulic oil.
- The battery's charge state.

Please note:

The acceleration and braking behaviour of the machine are influenced by viscous hydraulic oil. Before starting operation at a low ambient temperature, adapt the operating materials (coolant, oils etc.) to the low temperatures.

At temperatures below 0 °C (32 °F), use winter-grade fuel. Do not charge batteries at temperatures below 0 °C (32 °F).

Extensive ambient temperature, extensive height

At high ambient temperature and/or use of the machine at high altitudes:

- Do not completely fill the fuel and operating liquid tanks/reservoirs.
- Adjust the control system to reduce the amount of fuel injected quality fuel engine.



Observe the instruction manual for the diesel engine.



1.03 Environmental protection

Send packaging, cleaning materials and used or residual operating materials for recycling. Observe the environmental protection regulations applicable at the place of use.



When operating the machine, observe the notes in this instruction manual in order to avoid unnecessary impact on the environment.

1.04 Disposal

Conservation of nature is one of our major tasks. Properly disposed devices avoid negative impacts on human beings and the environment and allows re-using our precious resources.

Operating supply items

Please dispose all operating supply items according to relevant specifications and local regulations of the relevant country.

Materials (metal, plastics)

To be able to dispose materials professionally, these materials need to be correctly sorted. Cleanse materials of adhesive impurities.

Please dispose all materials as demanded by local provisions of the relevant country.

Electrical/electronic system/battery

Electrical/electronic components are not subject to Directive 2012/19/EC and relevant national regulations (in Germany e.g. ElektroG).

Dispose electrical/electronic components directly at a specialised recycling company.



1.05 EC conformity

The declaration of conformity is part of the documentation provided separately and will be submitted to you together with the machine.



The pictogram represents the machine's conformity.



For machines without EC Conformity, neither an EC Declaration of Conformity nor a CE type plate can be issued. This is the case if, for example, the machine does not have a drum drive, drum brake or ROPS.



If the machine type plate does not bear a CE pictograph, the machine does not correspond to the applicable EU Directives. Any operation of this machine in the European Economic Area (EEA), in Switzerland and in Turkey is inadmissible.



In case the machine has been modified in a way that has not been agreed by the manufacturer, the EC declaration of conformity expires.

**EC declaration of
conformity**



Manufacturer: HAMM AG - Hammerstraße 1 - D-95643 Tirschenreuth

CE

EC DECLARATION OF CONFORMITY
according to EC Machinery Directive 2006/42/EC, Annex EA

We hereby declare that the

Designation of the machinery:
Type:
Serial no.:

complies with the following provisions:

- EC Machinery directive 2006/42/EC
- EMC Directive 2014/30/EU
- EC Sound directive 2000/14/EC
with evaluation form: Annex VII

Notified Body: Notified Body Number: 0515

measured L_{Aeq} (dB(A))
guaranteed L_{Aeq} (dB(A))
Power (kW/min⁻¹)

- Emissions standard EU/USA:
- Exhaust gas after treatment:

Applied harmonised standards, in particular:

- EN 500 1:2006+A1:2009: Mobile road construction machinery - Safety
Part 1: Common requirements
- EN 500 4:2011: Mobile road construction machinery - Safety
Part 4: Specific requirements for compaction machines
- EN ISO 3744:2010: Allocation of the sound capacity level of sound sources

Authorised agent for the composition of the relevant technical documents:
Mr. Matthias Lob, HAMM AG ICE representative

Tirschenreuth, _____
Date

Dr. Axel Römer
Head of Research and Development

1. Nachdruck, Vertrieb 0515 05647 Fax: 0515 05647 E-Mail: info@hammag.com oder info@hamm.com



1.06 Type plate

The entire marking represents an official document and must not be altered or effaced.



The pictogram represents the machine's conformity.



If the machine type plate does not bear a CE pictograph, the machine does not correspond to the applicable EU Directives. Any operation of this machine in the European Economic Area (EEA), in Switzerland and in Turkey is inadmissible.



The EAC (Eurasian Conformity) pictogram confirms the conformity of the machine with the requirements of the Eurasian Customs Union



Please state the vehicle identification number (VIN) and the type of your machine for every spare part order.

Machine type plate

The type plate is fixed to the machine frame ("Chassis/safety devices", page 36).

			
Homologation	①		
Beschreibung Description	②		
Typ Type	③	Baujahr Year of Manufacture	④
Fz. Ident. Nr. Prod. Ident. No. (VIN)	⑤	Leergewicht Basic Weight	⑦ kg
Motorleistung Engine Power	⑥	kW/min ⁻¹	Betriebsgewicht Operating Weight
Max. Betriebsgewicht Maximum Operating Weight			⑧ kg
Zul. Gesamtgewicht STVZO Admissible Total Weight STVZO			⑩ kg
Zul. Achslast vorn / hinten STVZO Admissible Axle Load front / rear STVZO			⑪ kg
Hersteller: HAMM AG - Hammstraße 1 - D-05643 Tirschenreuth - Germany Made in Germany			

[1] Homologation (for example the registration driving on public roads)	[2] Description
[3] Type	[4] Year of construction
[5] Vehicle identification number (VIN/PIN)	[6] Engine power/Nominal speed
[7] Basic weight	[8] Operating weight
[9] Max. Operating weight	[10] Gross vehicle weight rating STVZO (only valid on public roads)
[11] Permissible axle load, front/rear STVZO (only valid on public roads)	



17-digit vehicle identification number

The vehicle identification number [5] is used to identify, among other data, the machine's series and serial number, e.g., WGH0H184CHAA01234. Digits # five to eight indicate the series (H184), while the last four digits represent the serial number within this series (1234).



The maximum operating weight [9] is the static weight of the machine including:

- Working substances and lubricants
- 100 % fuel tank contents × 0.84 specific weight
- 100 % water & additive tank contents
- 75 kg for the driver
- the static weight of all options or attachments manufacturer the same time and approved by manufacturer (e.g., chip spreader).

No additional ballasting is allowed.

ROPS/FOPS type plate

The ROPS (cab, roll-over bar) and/or FOPS (falling-object protective structure) approved for this machine by the manufacturer is identified by a nameplate and is fastened to the cab/roll-over bar ("Control stand", page 44).

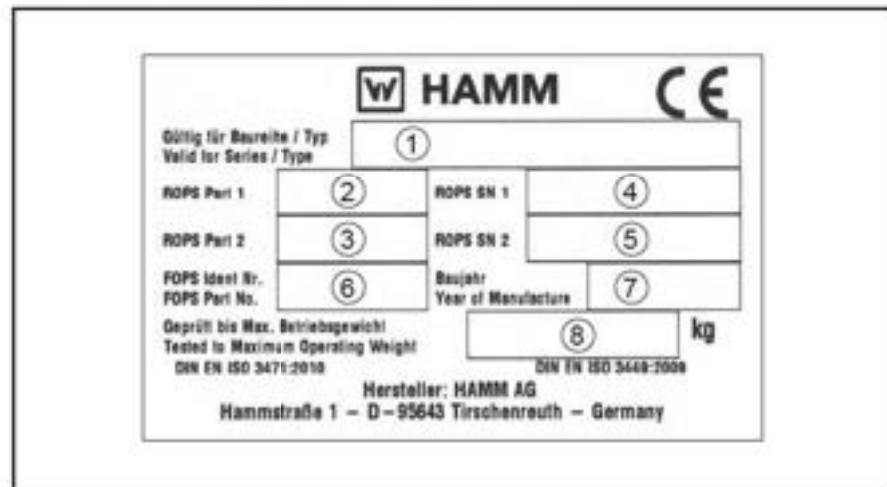

[1]	Series/type (part of the VIN/PIN)	[2]	Cabin/ROPS identification number 1
[3]	Cabin/ROPS Identification number 2	[4]	Cabin/ROPS Serial number (if available) 1
[5]	Cabin/ROPS Serial number (if available) 2	[6]	FOPS identification number (if installed)
[7]	Year of construction	[8]	Tested up to the maximum operating weight



Engine nameplate

The engine approved by the manufacturer for this machine is also indicated by a specially produced type plate. It is located on the side of the machine type plate (in the engine compartment).

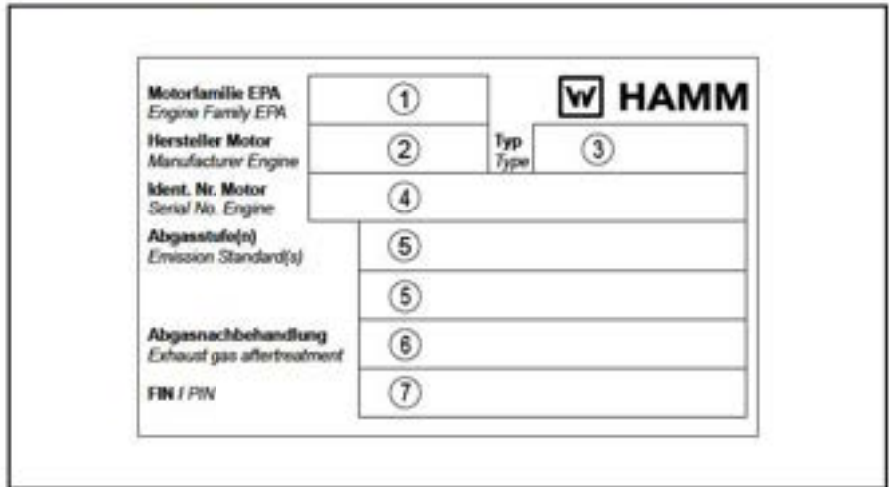

[1]	EPA engine family	[2]	Engine manufacturer
[3]	Type	[4]	Engine identification number
[5]	Exhaust emissions category/categories	[6]	Exhaust gas after-treatment
[7]	Vehicle identification number (VIN)		

1.07 Noise and vibration requirements

The sound emission of the machine was measured according to the CE Sound Emission Directive in the version 2000/14/EC.

The noise and vibration data at the driver's seat correspond to the requirements of the EC Machinery Directive, version 2006/42/EC.

Sound power level

Sound indication of the machine

The guaranteed sound power level is specified in the technical data (see "Technical data").

Emissions sound pressure level

Noise data at the driver's seat

The emissions sound pressure level at the driver's seat is specified in the technical data (see "Technical data") (measurement uncertainty in accordance with DIN EN ISO 11201).



When working in the immediate vicinity of the machine, values may exceed 85 dB(A). In this case, please always wear personal protective equipment (ear protection).

Vibration data at the driver's seat

Whole-body vibrations

The weighted effective acceleration values, as per DIN EN 1032, for whole-body vibrations at the driver's seat of $a_w = 0.5 \text{ m/s}^2$ are not exceeded.

Hand arm vibrations

The weighted rms values of the acceleration with hand arm vibrations have been assessed in accordance with DIN EN 1032 and do not exceed $a_{hw} = 2.5 \text{ m/s}^2$.



1.08 Personnel

1.08.01 Qualification and duties

Operating personnel

All activities at the machine must be carried out by authorised operating personnel only. For the purpose of this instruction manual, operating personnel shall be deemed to include every authorized person entrusted with operating, maintaining, installing, setting, cleaning or transporting the machine.

This comprises the following persons:

- Machine operator
- Maintenance personnel

Persons are deemed as authorised that have been trained, qualified and instructed for carrying out relevant activities at the machine and that have proven their skills to the operating organization. The operating personnel must be authorized by the operating organization for those activities at the machine.

In addition to the qualifications specified in the safety instructions, the operating personnel must:

- Have read and understood the instruction manual.
- Be trained and instructed according to the rules of action in case of trouble.

Please adhere to the following instructions:

- Please drive the machine only if you are entirely familiarized with the operating and control elements and the method of operation.
- Please use this machine only according to its intended purpose.
- In case you detect any defects, such as at the safety equipment, that may affect the safe operation of the machine, please immediately notify the supervising body.
- With defects that may endanger persons, please stop operating the machine immediately.
- Please ensure that the machine is compliant with all requirements concerning traffic law.

Banksman/Spotter

Only such persons are allowed to instruct others in machines independently who also:

- Have been trained in instructing others (the machine).
- Have successfully proven their participation in such a course.
- Have proven their skills to the operating organization.
- Fulfil their tasks in a reliable manner.
- Have been appointed by the operating organization as a banksman/spotter.

The meaning of signals must be unambiguous between driver and banksman/spotter.

To avoid ambiguities, clarify hand signal, such as specified by the German BG Directive "Safety and Health Protection Signals at Work", must be used.

Please adhere to the following instructions:

- Please make yourself familiar with the machine's and the loading vehicle's dimensions.
- Wear reflective clothing.
- For instructing please use voice radio (e.g. when loading with a crane) or via hand signals (e.g. when reversing the machine).



1.09 General safety instructions

Safety manual	The safety manual is part of the instruction manual. Please make yourself familiar with these safety instructions prior to working with the machine.
Warning notes	Observe and follow the warning notes in this instruction manual and on the machine (warning signs) without fail.
Regulations and Provisions	In addition to this instruction manual, it is also necessary to adhere to all laws, standards, regulations and provisions applicable in the country of use and at the building site.
Additional information	If you obtain additional technical and/or safety-relevant information for the machine, they also must be adhered to and need to be attached to the instruction manual.
Electrical system	During working at the electrical system, the machine must be de-energised at the battery isolation switch (if available) or by disconnecting the negative terminal (ground strap) at the battery.
ROPS/FOPS protective structures	<p>The machine frame in the area of the ROPS/FOPS mounting must not be warped, bent or cracked (deformation). The reinforcing elements of the cab/roll-over bar (ROPS)/protective roof (FOPS) must not show any signs of rust, damage, hairline cracks or overt breakages. All screwed connections for the reinforcing elements must meet the prescribed specifications and must be securely screwed together. Pay attention to the tightening torques! Screws and nuts must not be damaged, bent or deformed. Any changes or repairs/fixes to the reinforcing elements are prohibited (see chapter "Auxiliary equipment").</p> <p>It is absolutely necessary to use a safety belt in proper working condition to be protected by the protective structures of the machine.</p>
Safety belt	The condition and function of the machine's safety belt must not show any damage or unacceptable wear such as to make the safety belt non-functional. It is absolutely necessary to use a safety belt in proper working condition. It is absolutely necessary to use a safety belt in proper working condition.

1.10 Driving on public roads

The following is applicable in Germany (StVZO – German Road Traffic Type Approval Law)

The government of Upper Palatinate grants an exemption permit (see the details indicated on the original) for this machine pursuant to section 70, subsections 1 and 2 of the German Road Traffic Type Approval Law (StVZO).

Notes:

- This exemption permit may be revoked at any time and applies to This corresponding vehicle owner only.
- A corresponding driving licence is required for operating this vehicle on public roads.
- The exemption may not be used unless an insurance cover is available.
- Both the original exemption permit and the original proof of insurance must be carried when driving the machine.



Increasing road safety

Before driving on public roads, remove the protective grille from the lighting package and/or the protective bar from the water tank.

The following is applicable outside

The laws, regulations, guidelines and standards applicable at the place of use must be observed (for example those concerning the lighting and warning systems).



1.11 Danger zone



The machine's danger zone is divided into the areas inactive and moving.



There are other danger areas when the machine is loaded by crane and transported. Also observe the instruction manual and the notes for the loading and transporting machines.

Zone "inactive"

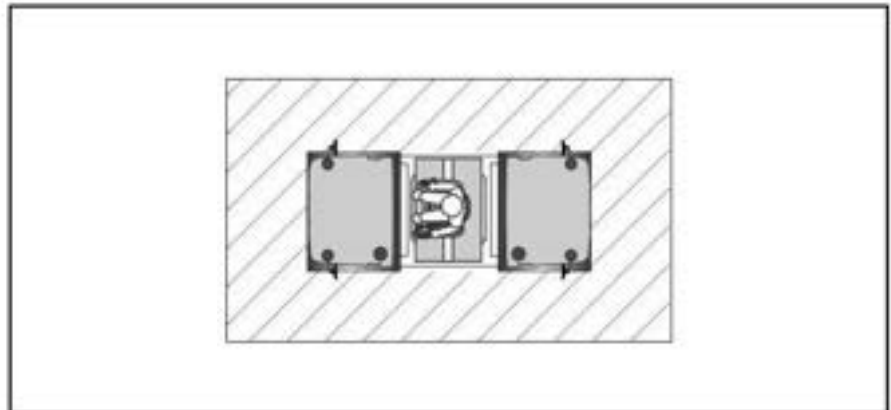

With the machine put out of operation and with the diesel engine switched off, an area 1 metre around the machine is defined as danger zone. No entry is allowed to the danger zone unless to operating personnel.

Zone "moving"

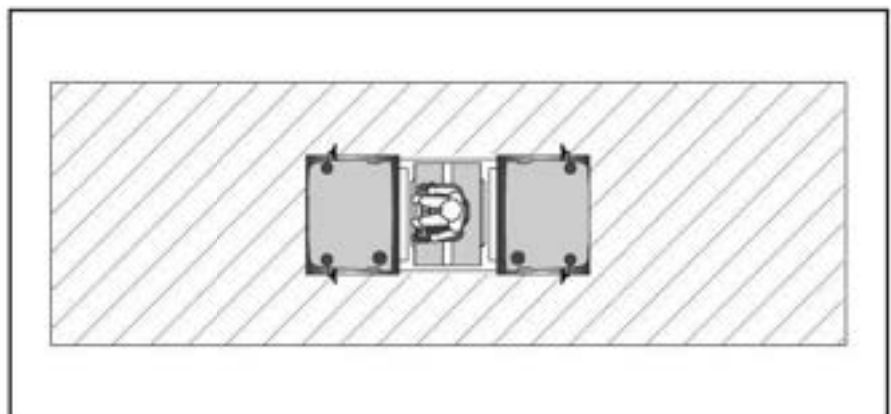

For a moving machine the danger zone is defined as follows:

13 metres	In front of and in the rear of the machine
3 metres	To the left and right of the machine

During compacting work and transport operations ensure that no persons are within the danger area.

2 DESCRIPTION

2.00 Information on the machine



When working at the machine please always adhere to the instructions given in your Safety instructions!

2.00.01 Technical characteristics

Drive unit	Hydrostatic all-wheel drive <ul style="list-style-type: none">▪ infinitely variable▪ Single lever operation
Dynamic compaction system	Direct hydrostatic drive
Steering	Hydrostatic assisted steering via three-point articulation <ul style="list-style-type: none">▪ Large steering angle to both sides▪ Pendulum compensation upwards and downwards
Track offset	Mechanical track offset <ul style="list-style-type: none">▪ infinitely variable▪ Track offset to the right
Service brake	During operation, the machine is braked with the hydrostatic drive. <ul style="list-style-type: none">▪ Wear-free brakes
Parking brake	Spring-operated brake acting upon each hydromotor of the drive. <ul style="list-style-type: none">▪ Manually and automatically
EMERGENCY STOP	Machine is braked with spring-operated brakes and hydrostatic drive.
Water sprinkling	Pressure sprinkling <ul style="list-style-type: none">▪ Manual actuation▪ Interval automatic
Additive sprinkling	Pressure sprinkling <ul style="list-style-type: none">▪ Manual actuation
Electrical system	Operating voltage 12 V
Drive system	Diesel engine

2.00.02 List of auxiliary equipment

The following list shows possible (optional) special attachments. This operating manual also describes special attachments that may not be present on your machine. Please contact your customer service if you have any questions about availability.



Special attachments are not specifically marked in the operating manual. Please observe chapter 6. You will find more detailed information about special attachments here.



Auxiliary devices may change the sequence of action steps or events. This is indicated by an additional note in the text, for example: **For versions with an air conditioning system.**

- ROPS (roll-over bar), rigid or folding
- Mechanical seat adjustment
- Anti-freeze filling system
- Back-up alarm
- Lighting package for driving on public roads
- Working spotlights
- Rotating beacon
- Drum edge lighting
- Battery isolation switch with mechanical remote control
- Lockable dashboard cover
- Smooth drum scrapers
- Protective roof
- Cup holder
- Lockable hydraulic oil tank cover

2.01 General view of machine

2.01.01 Chassis/safety devices



[1]	Lifting lugs for crane loading	[2]	Engine hood
[3]	Lashing point	[4]	Chassis
[5]	Safety strut	[6]	Steps
[7]	Vehicle identification number (VIN)	[8]	Machine type plate
[9]	Seat belt		

2.01.02 Stickers on the machine

Below please find a list of warning signs and information signs affixed to the machine. The images and values may vary according to the type of machine.



For the detailed arrangement of warning and information signs, please refer to the spare parts catalogue.



Be sure to observe the warning signs and information signs affixed to the machine and strictly follow their instructions.

Information sign

Below is a list of examples of the information signs. The images and values may vary according to the type of machine.



Drive lever function

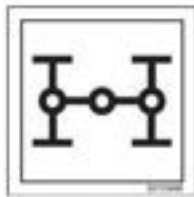

All-wheel lock



Engine speed



Water sprinkling



Inlet water tank

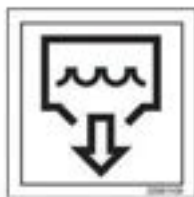

Water tank outlet



Additive sprinkling



Water tank inlet of additive sprinkling



Water tank outlet of additive sprinkling

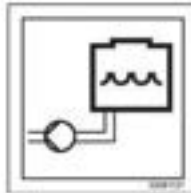

Water pump



Hydraulic oil filling level



Hydraulic oil reservoir inlet



Hydraulic oil reservoir outlet



Socket 12V



Engine oil outlet



Water sump fuel filter outlet

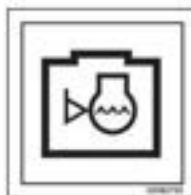

Coolant filling level



Coolant inlet



Inflation pressure



Guaranteed sound power level



First Aid



Expert inspection test badge



Maintenance overview



10 hrs; daily maintenance The activities that are shown on the sign must be carried out on a daily basis before starting up the machine – at least every 10 hours.

The check and maintenance work that is to be carried out may deviate from what is shown, depending on the model and equipment of the machine.

This is not an exhaustive representation of the activities. The sections "Functional checks before starting work" and "Maintenance overview" in this operating manual are binding and must be followed.



The sign is for informational purposes only. It should not and cannot replace instructions/training from the operator on how to handle the machine.



Check:

- Hydraulic oil fill level (top up if required)
- Coolant fill level (top up if required)
- Engine oil fill level (top up if required)
- Dust valve at the air filter (clean if required)
- Tyre pressure (correct if required)

Clean:

- Filter for the water-sprinkling system
- Sprinkler nozzles
- Drain the water sump on the water separator

Functional check in the case of an existing machine:

- Seat contact switch
- EMERGENCY STOP
- Safety switch for multifunction armrest
- Parking brake

2.01.03 ROPS

Version with rigid ROPS roll-over bar

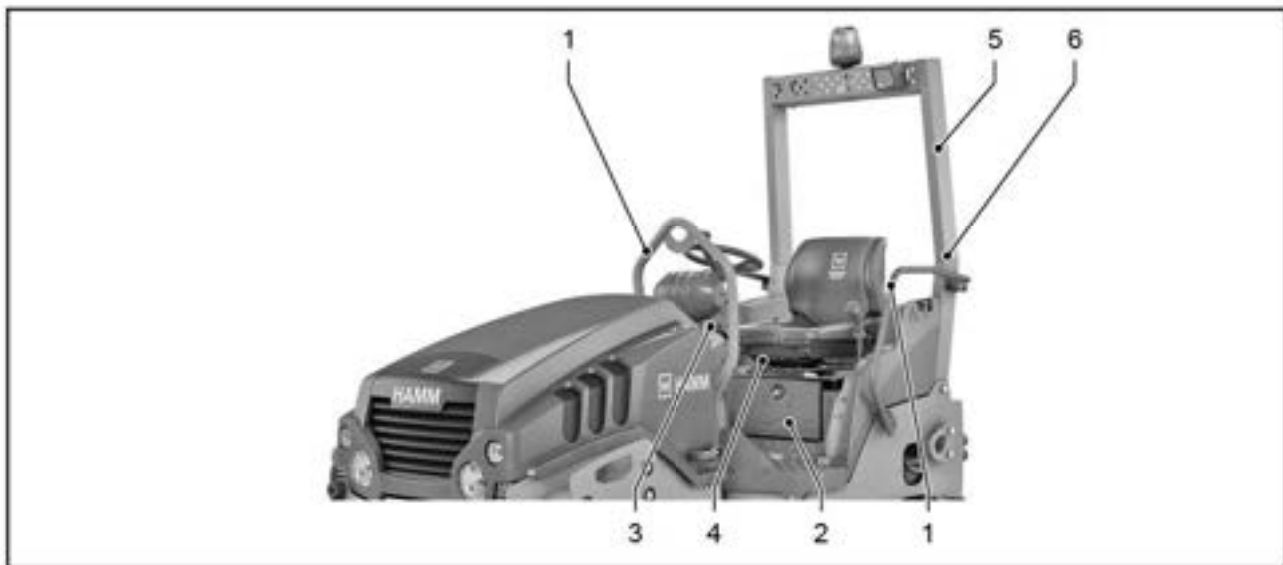

- | | | | |
|-----|-----------------|-----|--|
| [1] | Handrails | [2] | Storage compartment for instruction manual/first aid kit |
| [3] | Steering column | [4] | Operator's seat console |
| [5] | Roll-over bar | [6] | ROPS roll-over bar type plate |

Version with folding ROPS roll-over bar

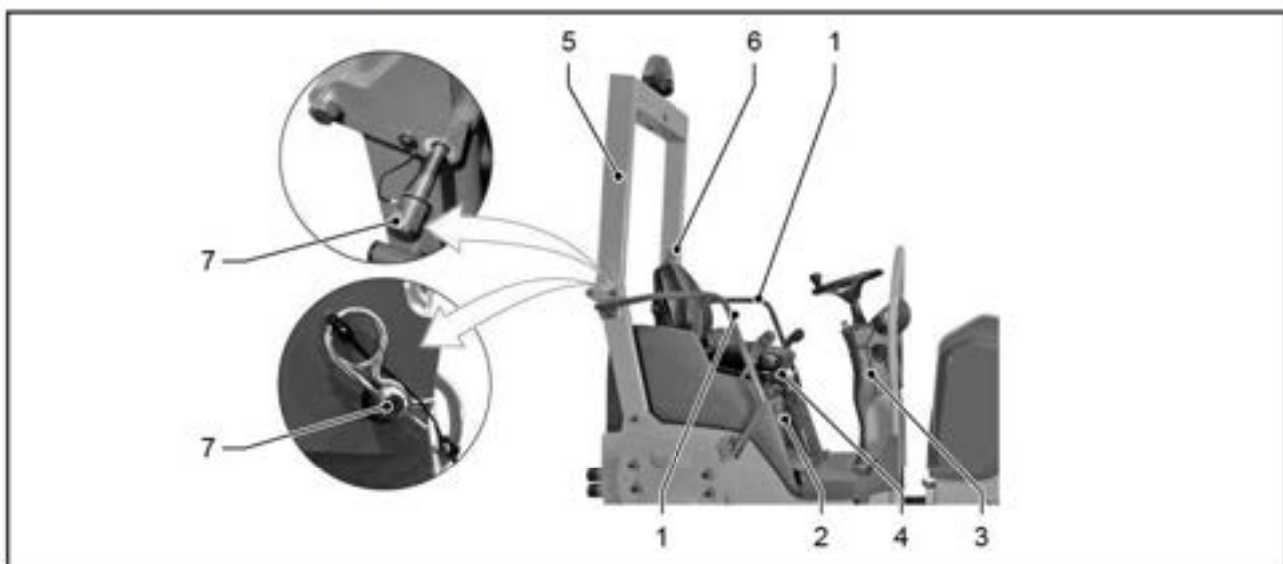

- | | | | |
|-----|-----------------|-----|--|
| [1] | Handrails | [2] | Stacker for instruction manual/first aid kit |
| [3] | Steering column | [4] | Operator's seat console |
| [5] | Roll-over bar | [6] | ROPS roll-over bar type plate |
| [7] | Locking pin | | |



2.01.04 Consumable fill holes

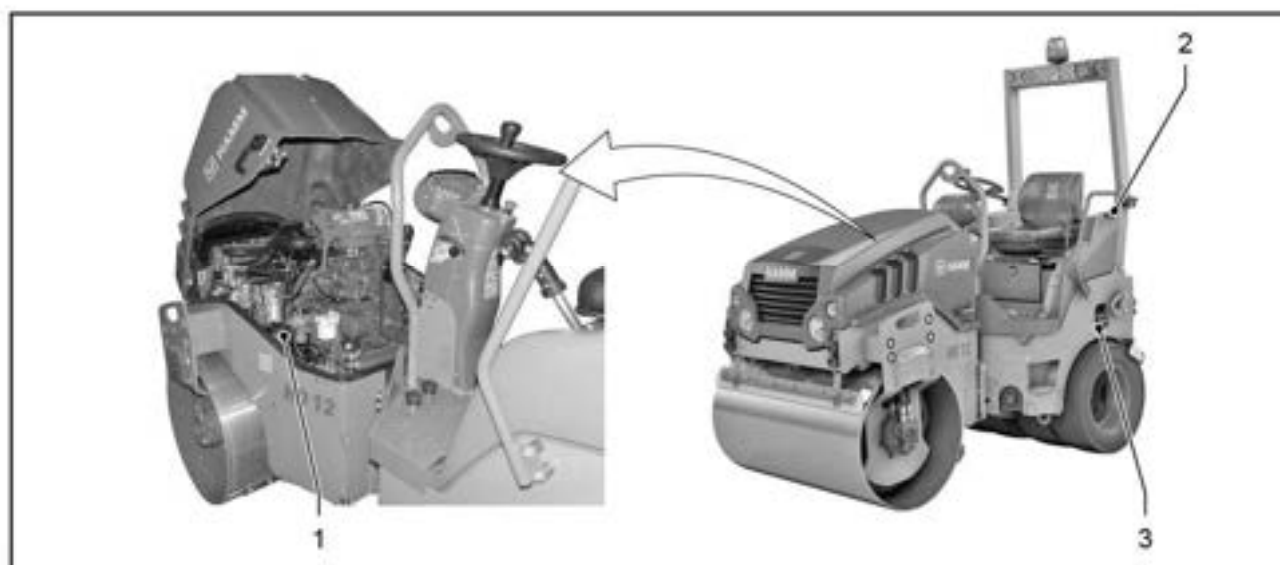

[1] Fuel

[2] Water sprinkling

[3] Additive sprinkling

2.02 Control stand

2.02.01 Seat console

Driver's seat design A



- | | | | |
|-----|--------------------------|-----|----------------------------------|
| [1] | Seat adjustment weight | [2] | Seat adjustment forward/backward |
| [3] | Seat adjustment backrest | [4] | Seat adjustment left/right |
| [5] | Safety belt | | |

Driver's seat design B



- | | | | |
|-----|--------------------------|-----|------------------------------------|
| [1] | Seat adjustment weight | [2] | Seat adjustment forwards/backwards |
| [3] | Seat adjustment backrest | [4] | Seat adjustment left/right |
| [5] | Seat belt | | |



2.02.02 Operating station controls

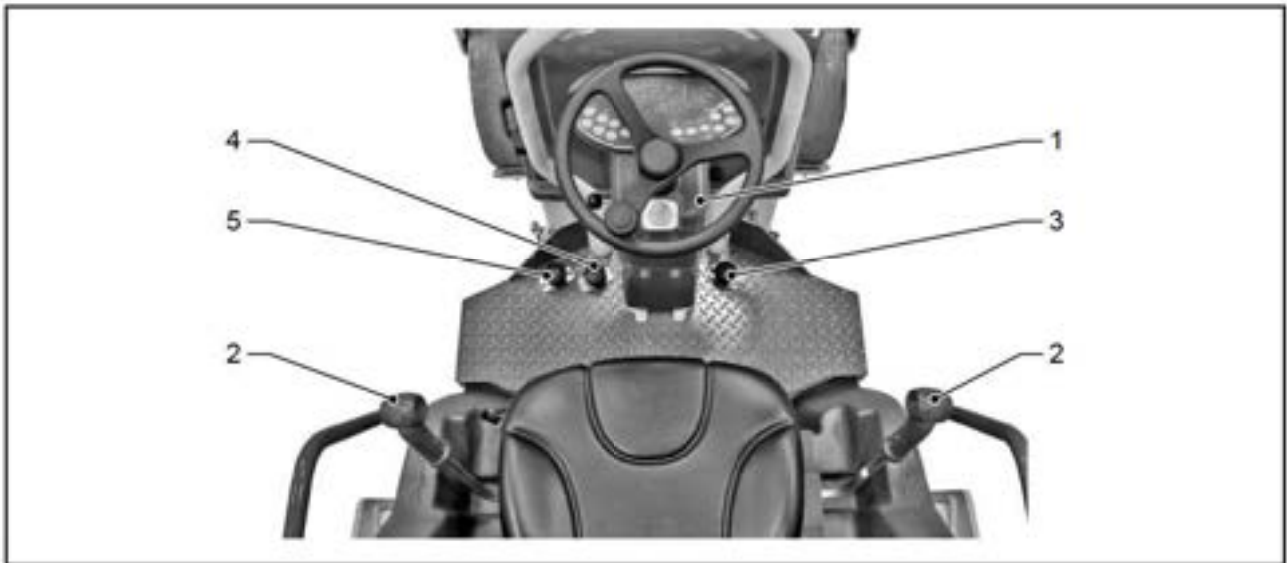

[1] Steering column

[2] Drive lever

[3] Switch all-wheel lock

[4] Switch sprinkling

[5] Additive sprinkling switch

2.02.03 Steering column

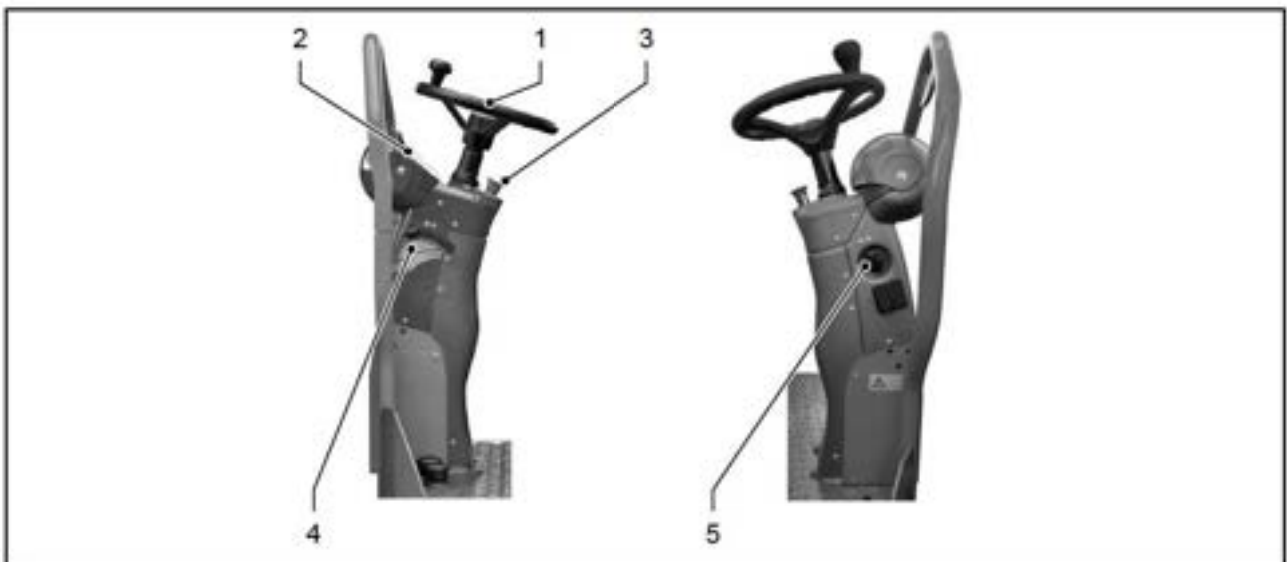

[1] Steering wheel

[2] Instrument panel

[3] EMERGENCY STOP

[4] Engine speed preselection

[5] Electrical system/engine start switch

2.02.04 Control panel

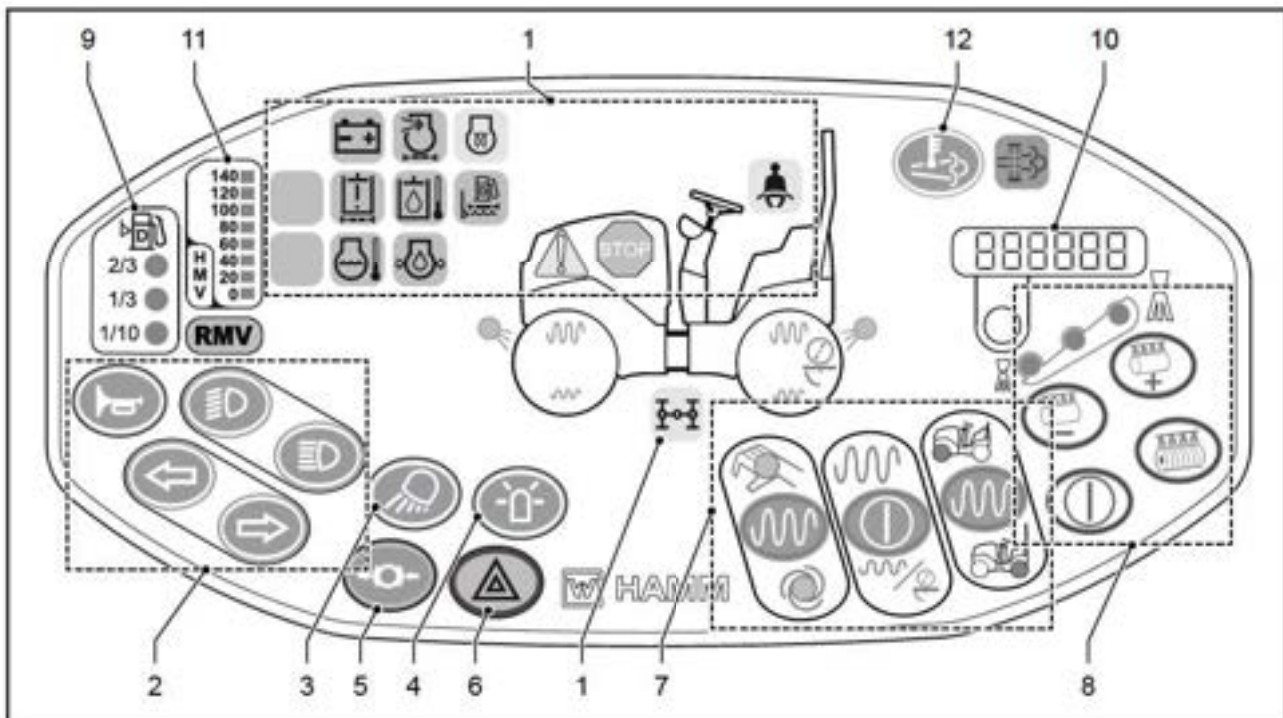

[1]	Warning or pilot lights	[2]	Driving light, blinker, signal horn
[3]	Work light	[4]	Rotary beacon
[5]	Parking brake	[6]	Warning flashers
[7]	Dynamic compaction system	[8]	Water sprinkling system control
[9]	Fill level indicator for fuel	[10]	Info display system info/diagnostic code
[11]	Indicator compaction	[12]	without function



2.02.05 Drive lever

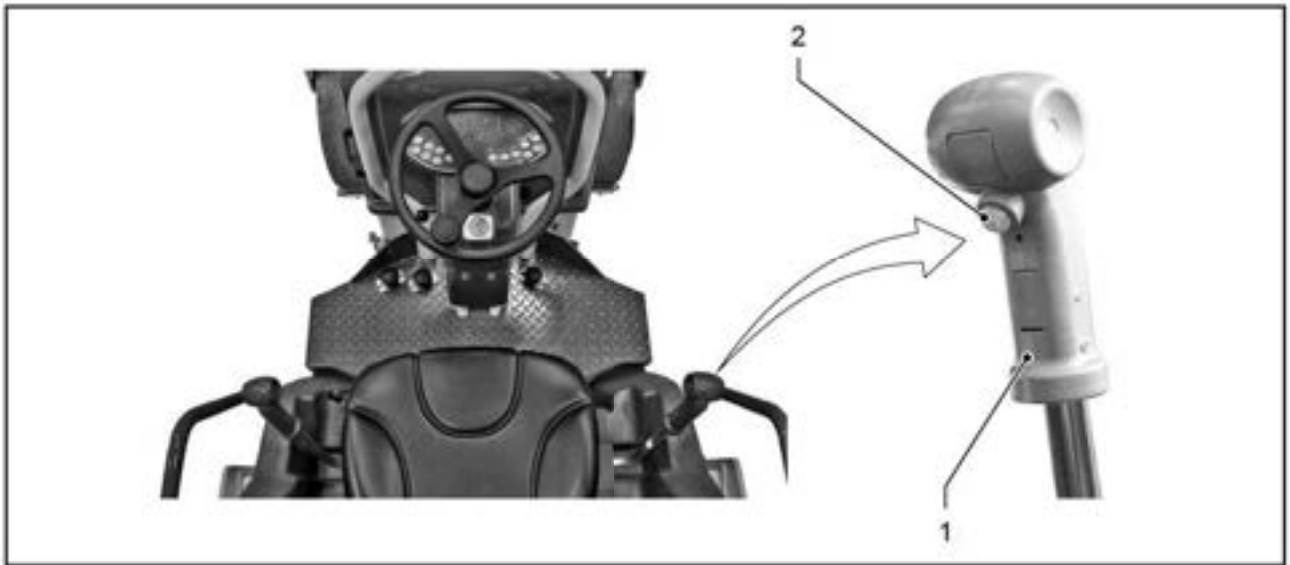

[1] Drive lever

[2] Dynamic compaction system ON/OFF switch

2.03 Drive unit/diesel engine

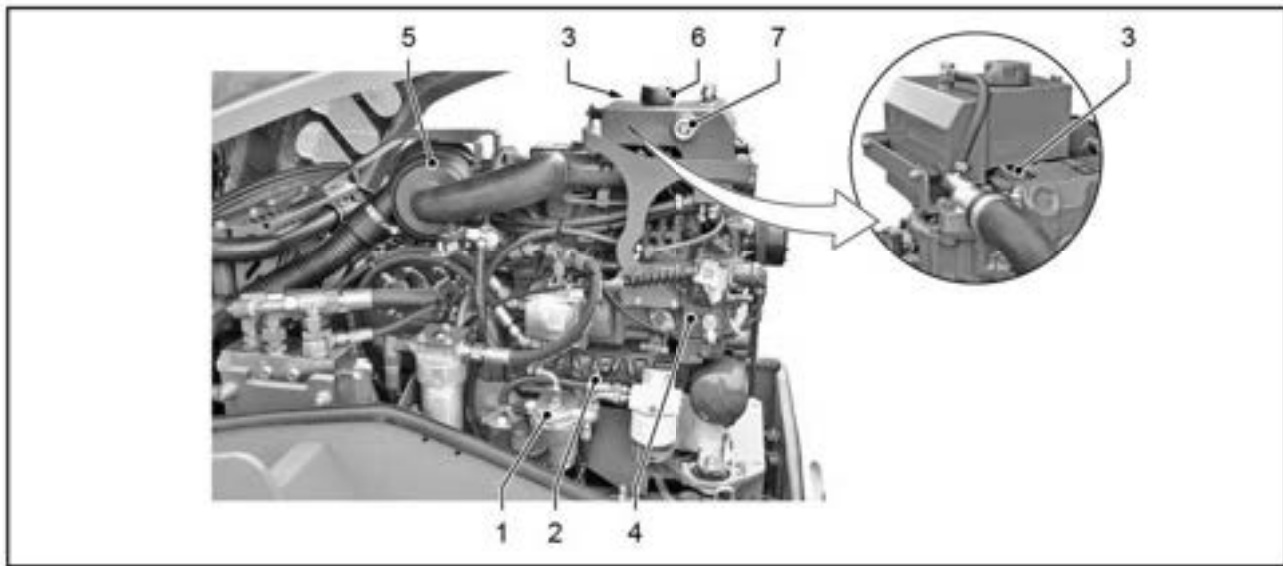

- | | | | |
|-----|--------------------------------|-----|--------------------------------|
| [1] | Fuel system | [2] | Engine oil dipstick |
| [3] | Filling opening for engine oil | [4] | Diesel engine with drive units |
| [5] | Air filter | [6] | Filling opening for coolant |
| [7] | Coolant level indicator | | |

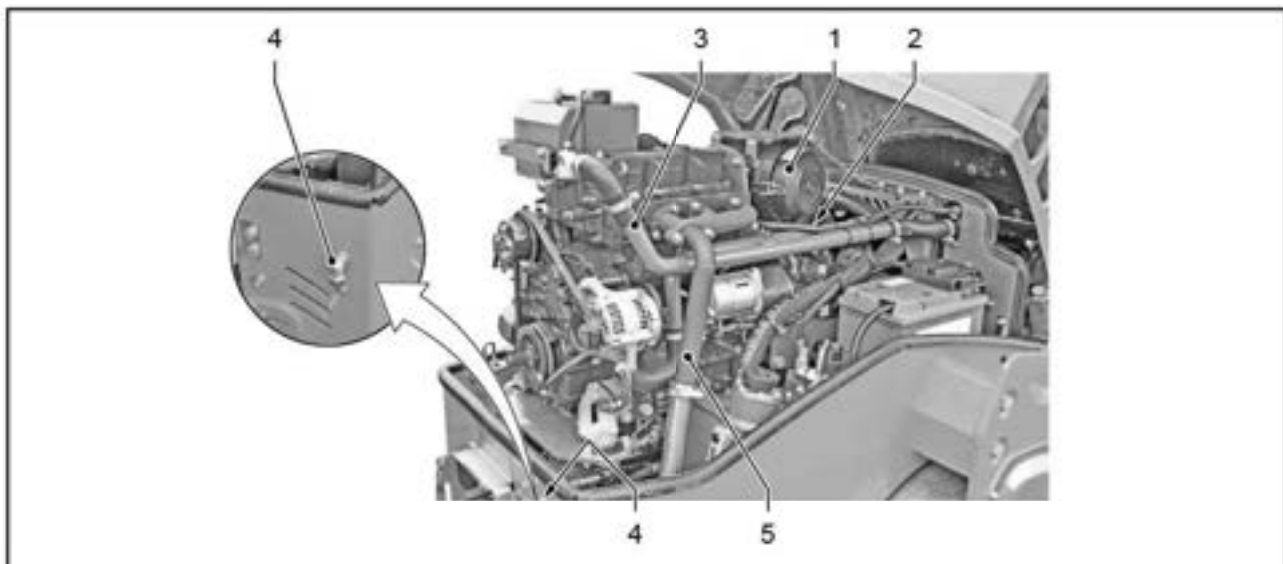

- | | | | |
|-----|--------------------|-----|-----------------------------|
| [1] | Air filter | [2] | Dust valve |
| [3] | Cooling system | [4] | Drain outlet for engine oil |
| [5] | Exhaust gas system | | |

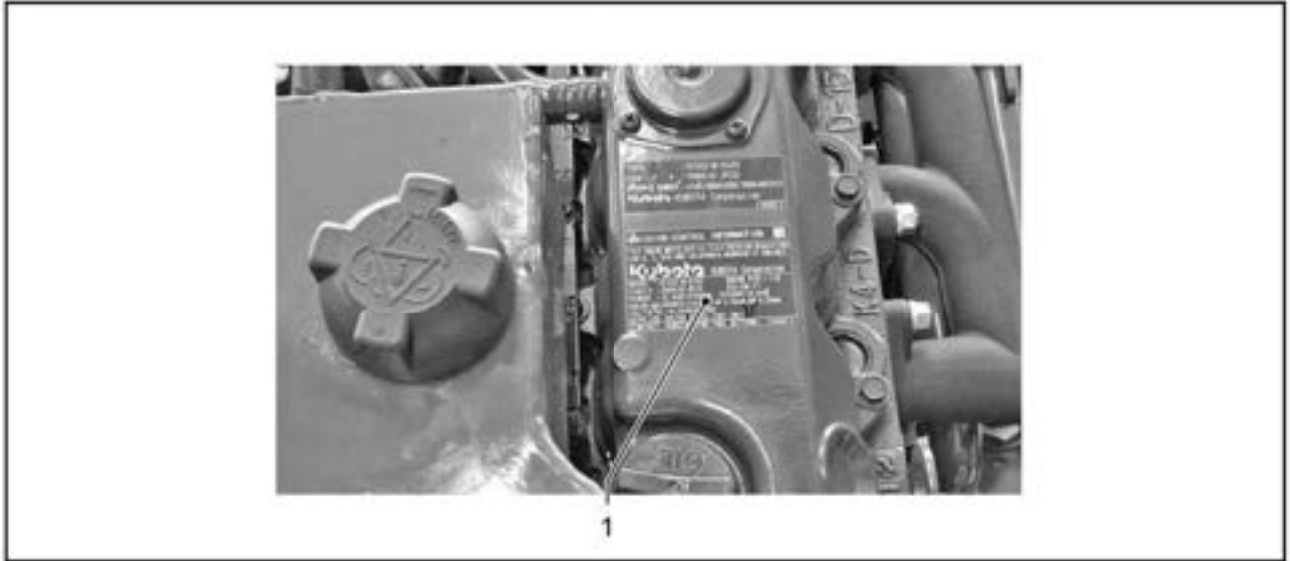

[1] Diesel engine type plate

2.04 Hydraulic oil supply

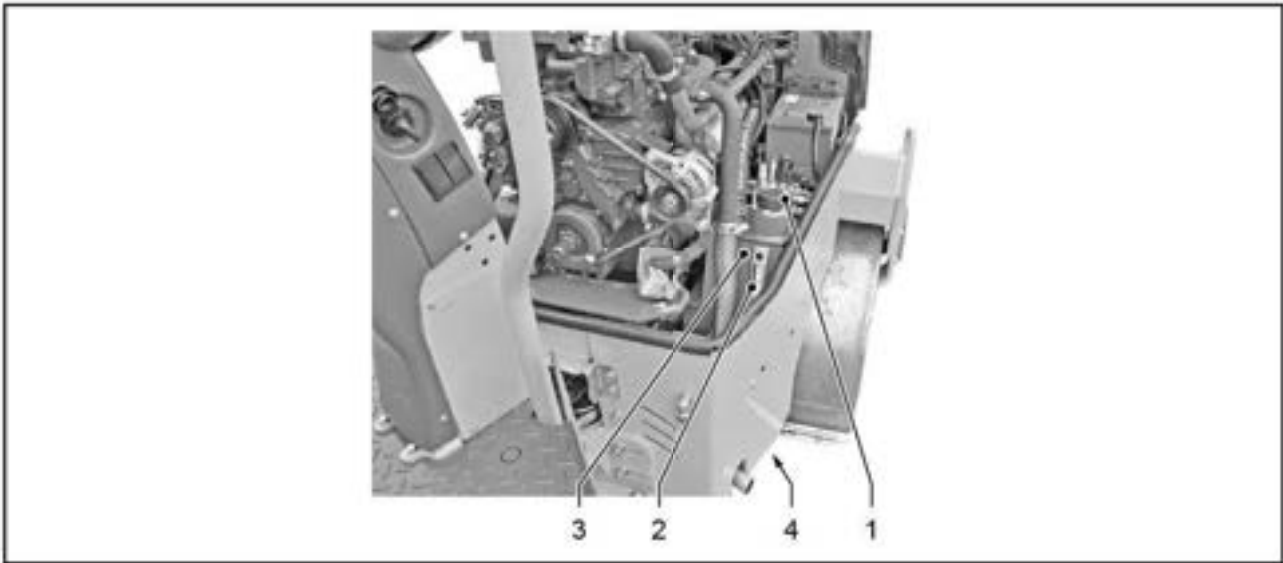

- | | | | |
|-----|-----------------------------------|-----|--------------------------------|
| [1] | Filling opening for hydraulic oil | [2] | Level indicator |
| [3] | Hydraulic oil tank | [4] | Drain outlet for hydraulic oil |

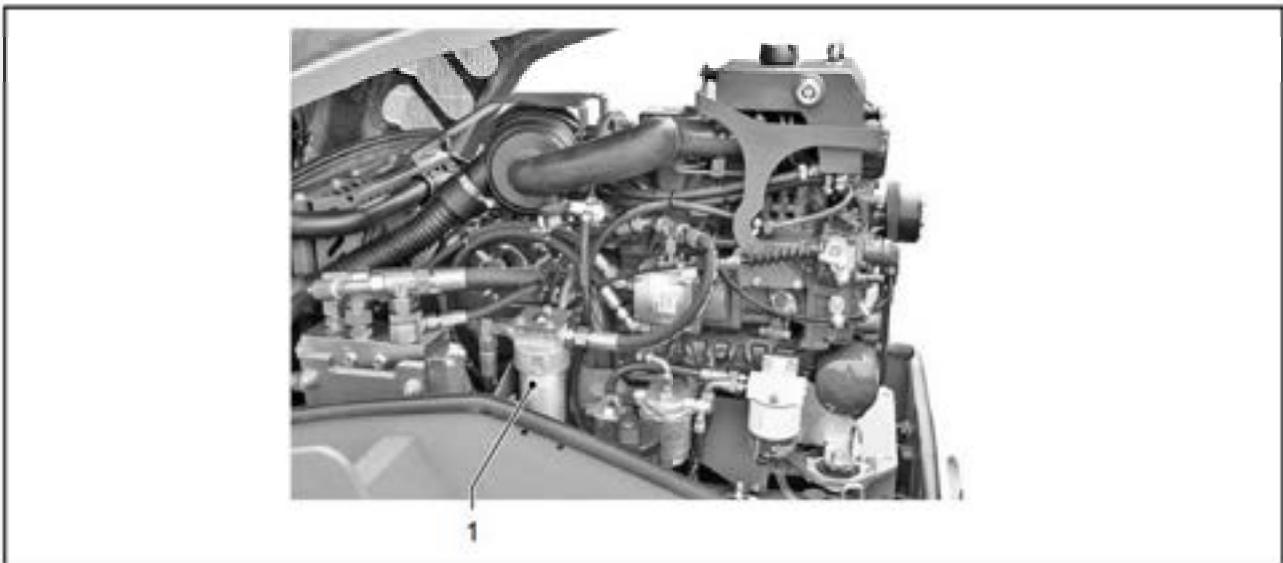

- | | |
|-----|----------------------|
| [1] | Hydraulic oil filter |
|-----|----------------------|



2.05 Electrical system

Engine compartment

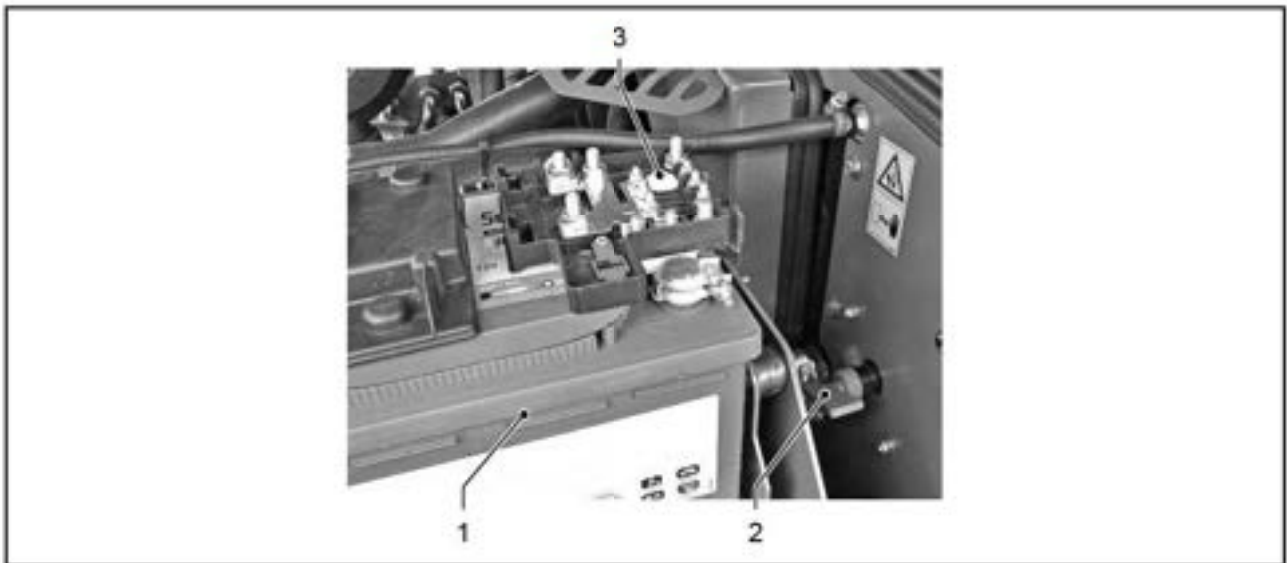

[1] Battery

[2] Battery isolating switch

[3] Main fuse

Control stand

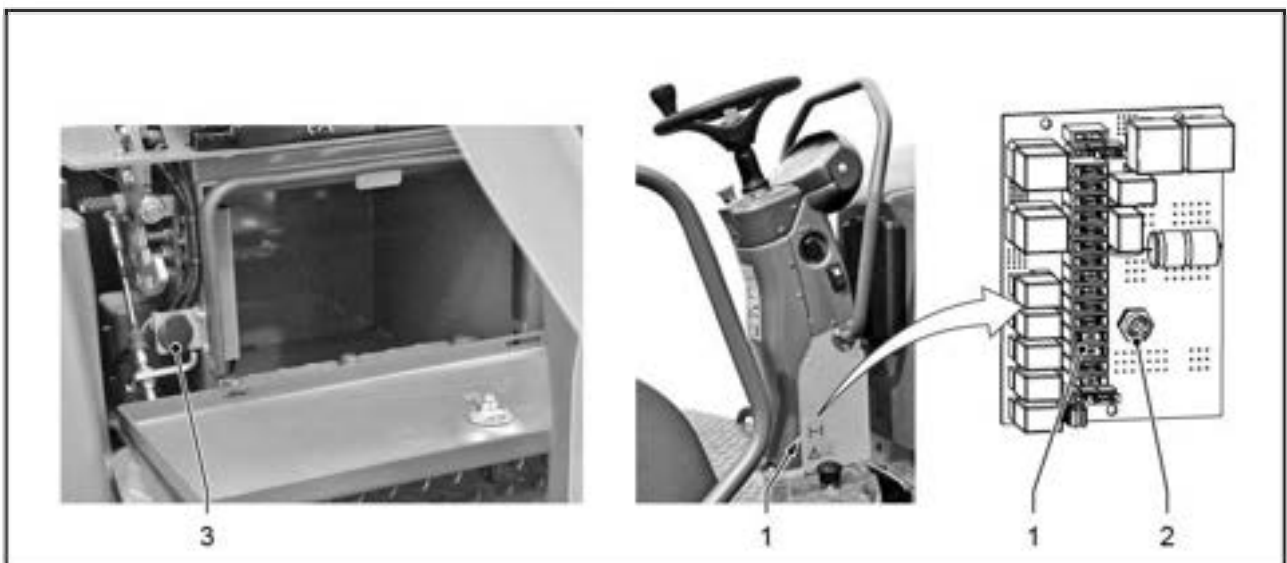

[1] Fuses

[2] Machine diagnostic interface - for version with add-on equipment

[3] Socket 12 V

2.06 Transmission

Tandem roller



- | | |
|-------------------------------|------------------------------|
| [1] Gear hub motor | [2] Roller drum scraper, top |
| [3] Roller drum scraper, down | |

Combination roller



- | | |
|-------------------------------|------------------------------|
| [1] Gear hub motor | [2] Roller drum scraper, top |
| [3] Roller drum scraper, down | [4] Scrapper tyres |



2.07 Steering system

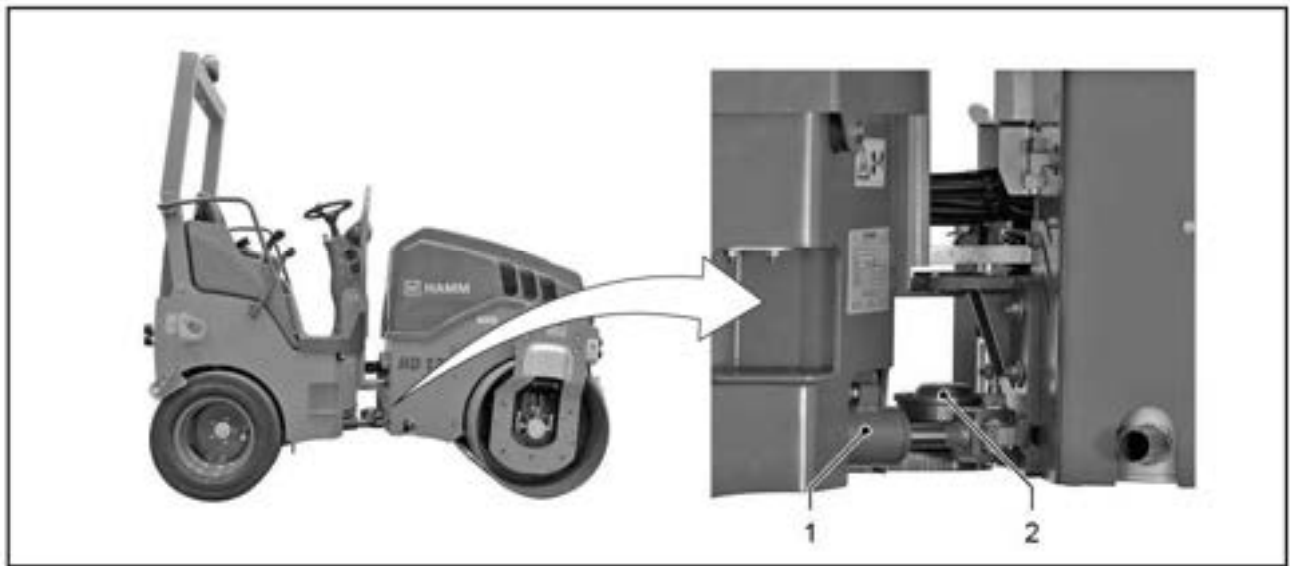

[1] Steering cylinder

[2] Three-point articulation

2.08 Water system

2.08.01 Water sprinkling system



- | | | | |
|-----|--------------------------------------|-----|----------------------------|
| [1] | Sprinkler nozzles of sprinkling unit | [2] | Water tank filling opening |
| [3] | Water tank | [4] | Water tank drain outlet |
| [5] | Water filter | [6] | Water pump |

2.08.02 Additive sprinkling

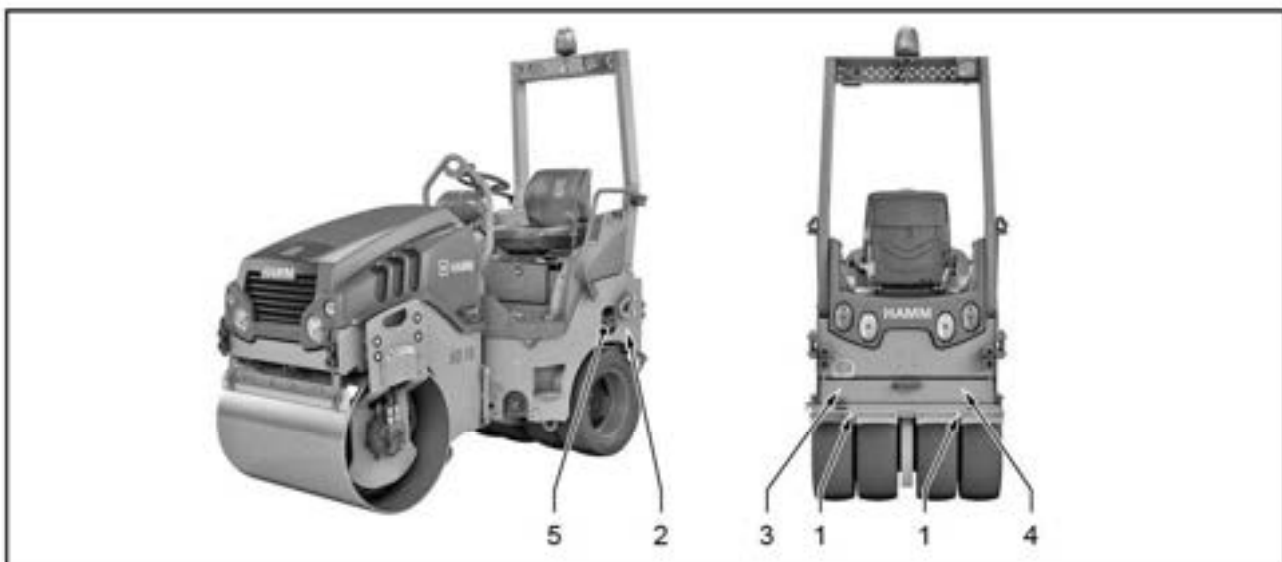

- | | | | |
|-----|--|-----|----------------------------|
| [1] | Sprinkler nozzles of additive sprinkling | [2] | Additive tank |
| [3] | Water pump for additive sprinkling | [4] | Additive tank drain outlet |
| [5] | Additive tank filling opening | | |



2.09 Dynamic compaction system

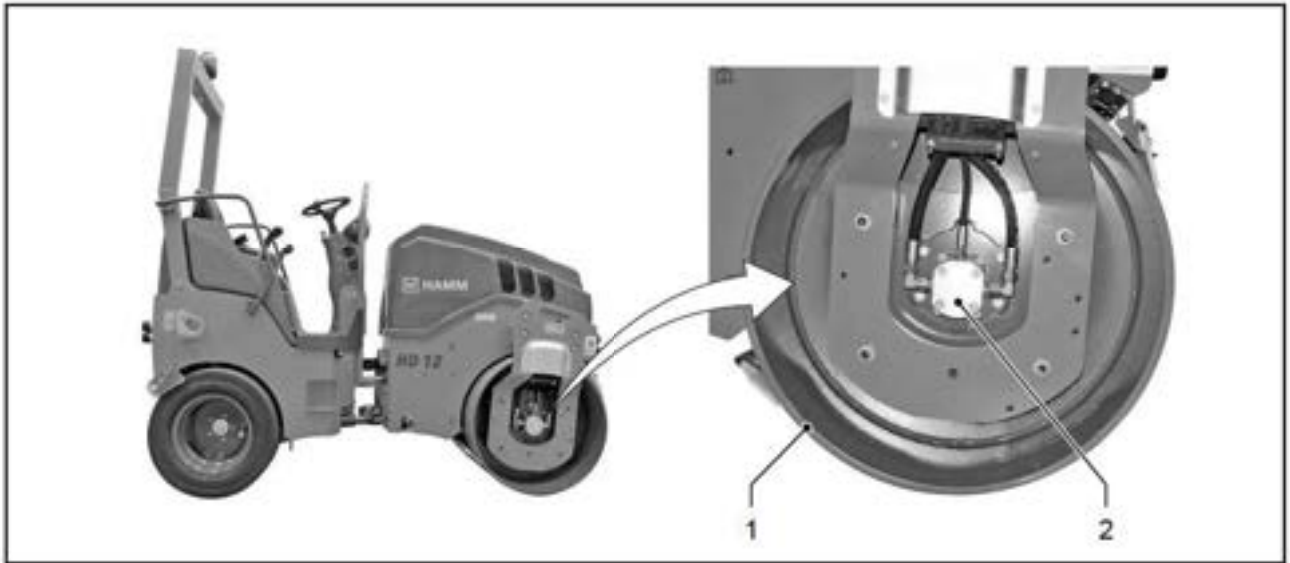

[1] Drum with vibrator/oscillator

[2] Vibration drive motor



3 OPERATION

3.00 Important information about operating the machine

Operating the machine requires specialist knowledge about driving construction machines. Only authorized operating personnel may operate the machine.

The following safety instructions apply to all operating activities machine.

▲ DANGER

Operating errors!

Danger to life and limb and risk of injuries and material damage through improper operation of the machine.

- Check the machine for operational and traffic safety.
- Read and observe the instruction manual and the safety manual.
- Ensure that there are no persons or objects in the danger zone of the machine.

▲ DANGER

Uncontrolled driving behavior!

Risk of fatal injury due to the machine's own driving movements or due to any uncontrolled movement.

- Do not continue to operate the machine in the event of error messages about safety-related components. Switch off the machine, park it in a safe place, and inform customer service.
- Allow only specially trained and authorized personnel to work on safety and control-relevant components.
- After work on control-relevant component, the control system must be reset by authorized service personnel.

▲ WARNING

Exposed, rotating parts!

Risk of being trapped, pulled in, and injured by rotating engine parts.

- Operate the machine only with the engine bonnet and the engine compartment door closed.
- Do not perform any testing and adjusting work in the area of the engine unless the diesel engine has been switched off.
- Do not lay down any object or tool in the engine compartment.

▲ WARNING**Uncontrolled movement!**

Injuries caused by the uncontrolled change of position of adjustable elements of the driver's platform while driving.

- Only drive when the adjustable elements of the driver's platform are engaged.
- Do not adjust the driver's seat, seat console, steering column or control panel unit while driving.
- Observe the clearance between body parts and machine parts.

▲ WARNING**Unintended machine movement!**

Serious injuries or death through unexpected movement of the machine during testing and setting work, and outside the operation.

- Do not carry out any testing and adjusting work unless the engine has been stopped and the ignition has been switched off.
- Park the machine on safe ground, i.e., flat and horizontal ground with sufficient bearing capacity.
- Secure machine against rolling away.

▲ WARNING**Unintended engine start!**

Severe injury and death caused in case of an unintended engine start during testing and adjusting work.

- Do not carry out any testing and adjusting work unless the engine has been stopped and the ignition has been switched off.
- Before starting testing and adjusting work, set the battery isolating switch to off in order to de-energize the electrical system. As an alternative, disconnect the earthing/grounding strip from the battery.
- To avoid any unintended engine start by any third person, affix a warning notice at the driver's position indicating that work is in progress on the machine.

▲ WARNING**Noxious exhaust gases!**

Risk of serious injury or death caused by poisoning or suffocation after breathing in exhaust gases when operating the machine in an enclosed space.

- Only operate the machine outdoors.
- If the engine has to run in enclosed spaces:
 - Guide the exhaust gases outside (extension hose).
 - Ensure that there is a sufficient supply of fresh air, e.g. by using a ventilation system or by opening the doors.

**NOTICE****High self-weight of machine!**

Material damage under the heavy weight of the machine.

- When loading and transporting the machine use hoisting gear and means of transport suitable for the weight of the machine.
- Use the machine only on sufficient load-bearing soil.

NOTICE**Uncontrolled movements!**

Damage to machine or environment by uncontrolled steering system movements and by consequent front or rear end swings.

- Applying safety strut before:
 - crane loading the machine.
 - transporting the machine.
 - maintenance and repair work.



3.01 Before loading/transporting/commissioning

▲ WARNING

Heavy weight!

Serious injuries or death caused by crushing or getting caught during assembly.

- Perform installation work on firm ground (flat, stable, horizontal).
- Carry out fitting work only when the engine is stopped.
- Use suitable load suspension and hitching gear with an adequate loading capacity.
- Do not step underneath suspended loads.

3.01.01 Safety strut

▲ WARNING

Unintentional movement of the machine!

Severe injury or death due to unexpected machine movement during setting work.

- Do not connect or disconnect the safety strut unless the engine is stopped and the ignition is set to off.
- Park the machine on safe ground, i.e., flat and horizontal ground with sufficient bearing capacity.
- Secure machine against rolling away.

The safety strut is used to prevent uncontrolled steering system movements. This helps to prevent, e.g., the machine's front end or rear ends from swinging out.

Applying safety strut **always** before:

- crane loading the machine.
- transporting the machine.
- maintenance and repair work.



- Before inserting the safety strut, safely stop the machine
- Remove any steering angle (set the steering system to straight-line motion) and
 - Remove any track offset.

Applying safety strut

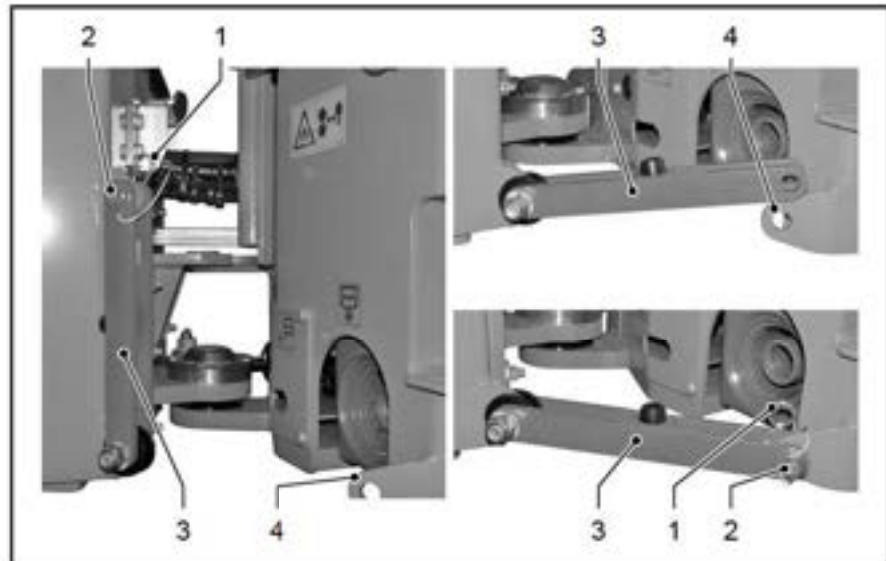

- ▶ Pull the spring cotter pin [1] out of the bolt [2].
- ▶ Pull out the bolt [2].
- ▶ Release the coupling bar [3] and swing it to the holder [4] located opposite.
- ▶ Use the bolt [2] to lock the coupling bar [3] in the holder [4].
- ▶ Slide the spring cotter pin [1] into the bolt [2].
- ✓ The safety strut is now installed.

Releasing safety strut

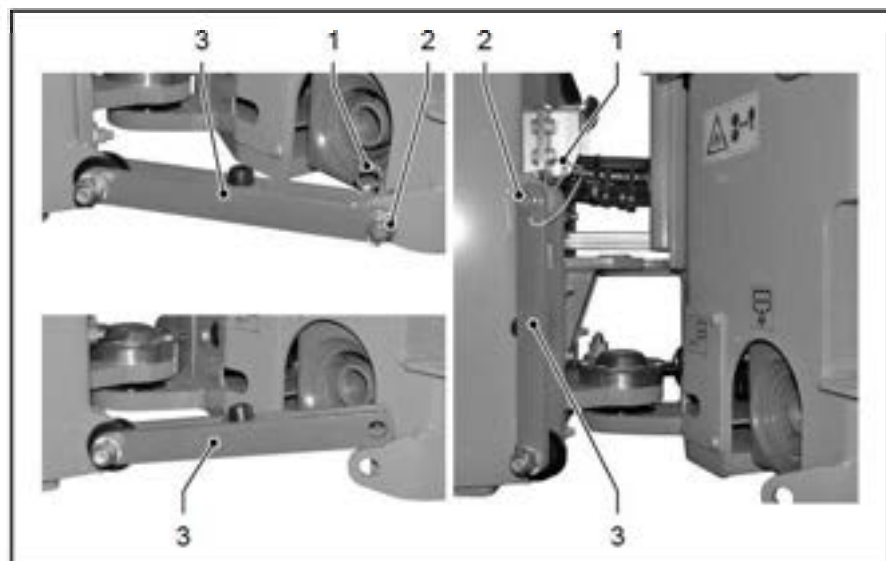

- ▶ Pull the spring cotter pin [1] out of the bolt [2].
- ▶ Pull out the bolt [2].
- ▶ Swing the coupling bar [3] upwards and press it down.
- ▶ Use the bolt [2] to lock the coupling bar [3] in place.
- ▶ Slide the spring cotter pin [1] into the bolt [2].
- ✓ The safety strut is released.

3.02 Loading and transporting



Observe all regulations when loading and transporting the machine to and from its place of use!

Regulations and Provisions

When loading rollers onto trucks, trailers or semitrailers, it is essential to secure the machine properly on the carrying vehicle. The duty for tie-down on street vehicles arises from StVO § 22, StVO § 23, StVZO § 30, StVZO § 31, HGB § 412 as well as from VDI guideline 2700 or other national requirements. Loading and transporting the machine requires sufficient knowledge about the loading of vehicles and their behavior under load. The machine may only be loaded by trained loading personnel. The machine must be fixed or stowed in transport-safe way to the vehicle by an form-locked or friction-locked manner or by a combination with friction. The machine must not change its position on the vehicle during normal traffic loads. Typical transport stresses also include emergency braking, evasive manoeuvres and unevenness of the road. If it is impossible to secure the machine properly onto the vehicle, or if the loading vehicle shows visible defects which do not ensure safe transport, loading must not be performed. This condition or requirement also applies to too little or damaged lashing tackle.

The transport company involved is always responsible for the safe transport of the machine and accessories.

Loading instructions

When loading please observe the following instructions:

- Adhere to section Transport as specified in the safety instructions.
- Note the weight and dimensions ("[Technical data](#)", page 177).
- Observe the legally required maximum height.
- Only use approved gantries or planks that are provided with an antiskid coating.
- Never drive with metal on metal.
- Keep all loading bridges, planks and loading areas clean. Remove grease, dirt, ice, etc.
- Clean roller drums and tyres prior to driving on the gantries.
- Guarantee a frictional force value μ of ≥ 0.6 , e.g. using anti-slip mats.
- For machines with an all-wheel lock, switch this on before driving over ramps or inclines.
- Drive the machine onto/off these with a 2/3 speed setting and the drive lever extended by 1/4.
- Either remove every loose or movable part in or at the machine, or secure such parts separately.
- Lower attachments.
- When transporting rollers with articulated steering, insert the steering block.
- Remove wedges and lashing devices completely before unloading. Unblock steering system by unblocking the safety strut.



- Drive the roller slowly and carefully from the loading area.
- For crane loading, always attach the suitable lifting tackle to the suspension eyelets provided for this. Position the crane vehicle on flat ground with the necessary load-bearing capacity, while taking into consideration all of the relevant safety regulations. Take suitable precautions to block access to the lifting area in order to prevent any persons from entering or moving in the danger zone. The crane's load table must correspond to the machine that is to be lifted. If just one of these points is not fulfilled, the crane loading must not take place.



Load securing

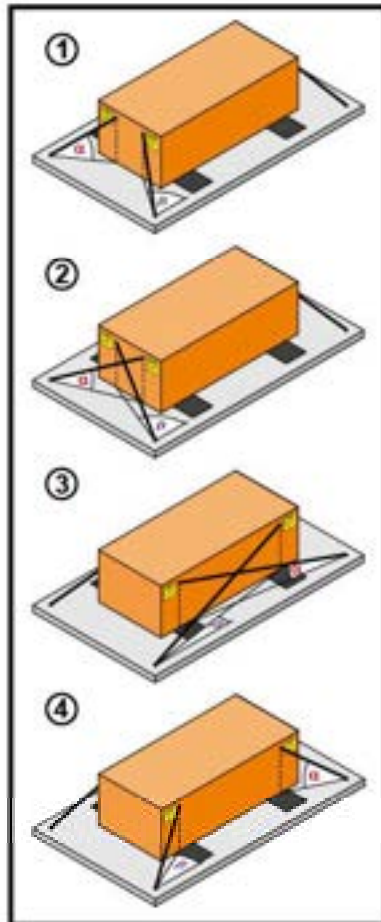

Special notes

- Variant ① and variant ② may be combined. The lashing devices must not necessarily be arranged crosswise.
- Do not use any lashing device unless it is of sufficient dimension, bears the corresponding marking, and has been subjected to a valid inspection.
- Lash the machine with appropriate lashing devices onto the loading area, using only the marked lashing eyes.
- Observe the load for the lashing point(s) at the vehicle/load platform and at the load/roller. Do not overload the lashing points with a tensioning device (see the loading chart).
- To increase load safety, use additional precautions for securing the load including, e.g., wheel stop wedges, or a positive fit at the goose-neck.



Store the machine on the load platform, placing two continuous and clean strips of anti-slide mats (grammage approx. 10 kg/m², loadable up to 630 t/m², 10 mm thick, friction factor $\mu \geq 0.6$) under every roller drum/tyre.

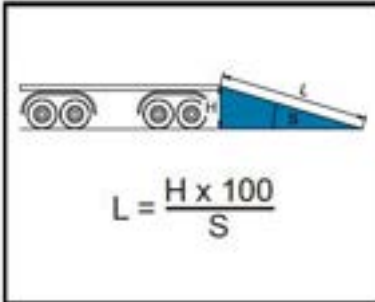

Maximum permissible ramp slope: see loading charts

[L] Ramp length [mm]

[H] Difference in height
[mm]

[S] Ramp slope [%]

Make certain to use a proper load distribution plan.

[☉] Centre of gravity





Crane loading

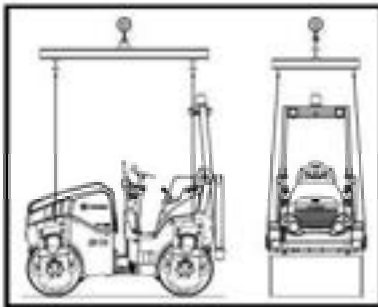
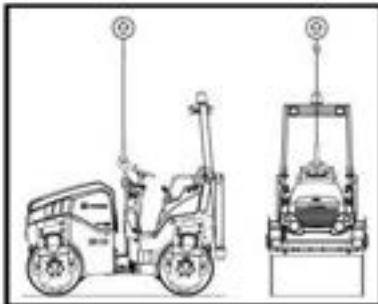

Special notes

- The crane vehicle must be positioned on flat ground providing the bearing capacity required. To do so observe all relevant safety regulations.
- The crane's load table must correspond to the weight and to the centre of gravity of the machine to be lifted.



If the weight of the machine is not known, set the maximum operating weight (see type plate).

- Take suitable precautions to block access to the lifting area in order to prevent any person from moving or staying within the danger zone.
- Attach hoisting gears to the appropriate lifting lugs provided for them.
- Observe the lifting capacity of the hoisting gears.
- Use lifting frames or spreader beams if necessary.
- Before loading by crane, engage the safety strut on the machine.

Loading chart

Diagram of the transport position

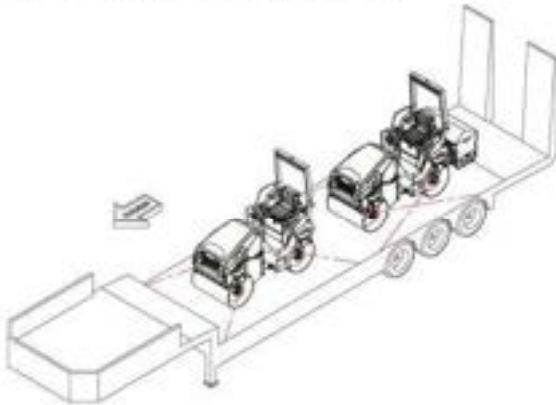
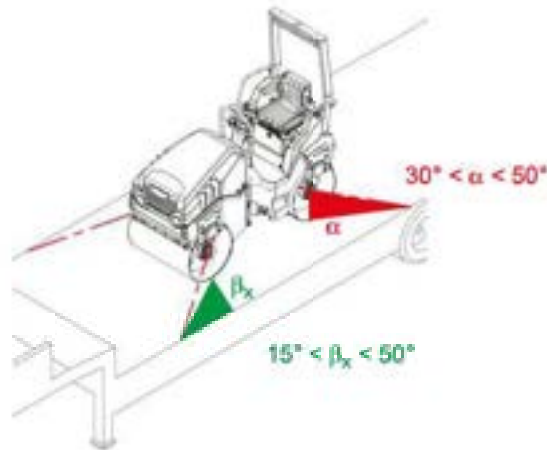
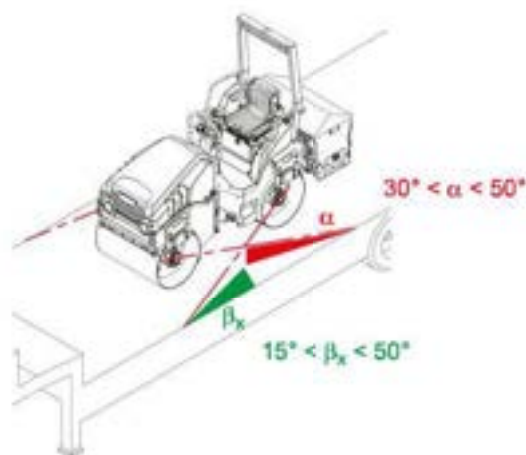

Diagram of the centre of gravity specifications



Lashing variant 1

Weight class [t]	Lashing capacity LC ($\mu=0.6$) [daN]
to 5.7	2000



Lashing variant 2

Weight class [t]	Lashing capacity LC ($\mu=0.6$) [daN]
to 5.7	2000



Machine parameters	
Weight of machine [t]	1,5 t < m < 5,7 t
Area of centre of gravity [mm]	$X_{CoG} = 778-1048$ $Y_{CoG} = 428-753$ $Z_{CoG} = 650-1030$
Identification reference point:	Centre drum, front left
Interface parameters:	
Type of contact:	Slip-resistant material
Frictional force [μ]:	0.6
Heavy load capacity:	yes
Contact points:	under contact pair
Vertical lashing angle α :	$30^\circ < \alpha < 50^\circ$
Longitudinal, horizontal angle β_x :	$15^\circ < \beta_x < 50^\circ$

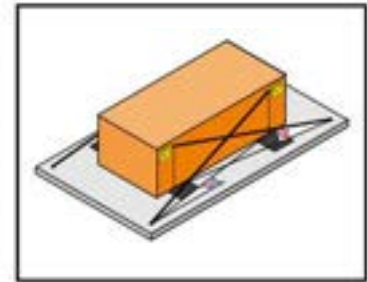
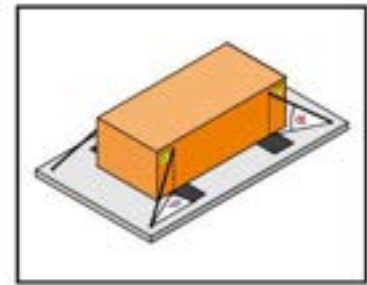

Specification of attachment points on the load:	
Tensile capacity of lashing point [daN]:	2000
Marking of lashing point:	Symbol ISO 6405-1
Number of lashing points:	4
Specification of lashing points on the means of transport:	
Tensile capacity of lashing point [daN]:	≥ 2000
Number of lashing points:	4
Load securing equipment:	
Wedge blocks:	no Quantity: 0 Miscellaneous:
Other types of blocking:	Positive blocking longitudinally/transversely to the direction of travel
Lashing equipment capacity [daN]:	10000 Quantity: 4 Miscellaneous:
Recommended type of lashing equipment:	Chain (6/8 2200 daN), Belt (2000 daN) as an alternative
Connecting pieces to the lashing point:	Hook with safety latch

Specific safety instructions

- Slowly drive the machine up/down with the speed set to 2/3 and the drive lever at the 1/4 position.
- Do not exceed the maximum ramp slope (28.5 %, approx. 16°).
- Secure the clamping devices.
- On rubber wheeled rollers with tyre filling system, the tyre filling system must be set to 0.6 MPa (6 bar, 87 psi).
- Check the inflation pressure at least every 24 hours and, if refill the air, if necessary (see Technical data).

Miscellaneous

- Lock the seat console in position
- Put down the add-on equipment



3.03 Functional tests before starting work

Check the following conditions to ensure that operating the machine is safe:

Testing	see
Can the machine be accessed safely?	page 69
Has the driver's seat been adjusted?	page 70
Has the seat belt been checked?	page 73
Has the position of the seat been adjusted?	page 70
Power supply to battery isolation switch is on	page 75
Are the turning signal and hazard warning lights working?	page 77
Is the signal horn working?	page 77
Are the lights working?	page 77
Is the reversing warning system working?	page 83
Is the rotating beacon working?	page 77
Is the parking brake working?	page 127
Is the EMERGENCY STOP working?	page 128
Has the fuel fill level been checked?	page 103
Coolant fill level checked?	page 138
Has the hydraulic oil fill level been checked?	page 141
Water tank fill level checked?	page 156
Additive tank fill level checked?	page 156
Air pressure in the tyres checked?	page 150
Scraper checked?	page 147



3.04 Access to the machine

▲ WARNING

Slipping when climbing in and out!

Risk of injury caused by slipping when climbing into and out of the machine.

- Use only the ladders, handrails and steps provided.
- Only climb into or out of the machine when it is at a standstill and secured in place.
- When climbing in and out, always ensure that any three of your hands and feet are in secure contact with the machine at all times.
- Keep ladders and steps clean and free of frost.
- If the anti-slip surfaces of the steps and treads are worn, repair or replace these.



[1] Step to driver's cab [2] Handrail

3.04.01 Access to the operator's platform

Access to the operator platform is possible from both sides of the machine.

Steps and handrails are arranged so that they are within easy reach and offer secure footing and handholds.

3.05 Adjust driver's seat

▲ WARNING

Uncontrolled motion!

Injuries due to uncontrolled movements when changing the driver's seat position when driving.

- Only drive with latched operator's seat.
- Do not adjust the driver's seat during travel.
- Free access to bodywork and engine parts.

The seat is adjusted to suit the size of the driver's body with the various setting options.

Driver's seat design A



Setting driver's weight

There is damping built into the driver's seat that compensates for shock-like machine movements. For this damping to function optimally, the seat must be adjusted to the weight of the driver.



Only adjust the weight setting when the seat is unloaded.

- ▶ Turn the lever into the corresponding position:
 - Light driver's weight (approx. 50 – 70 kg) – position I
 - Medium driver's weight (approx. 70 – 100 kg) – position II
 - Heavy driver's weight (approx. 100 – 130 kg) – position III

Setting the slope of the backrest

- ▶ Turn the hand wheel [2] in + (plus) direction.
 - ✓ The seat back is inclining backwards.
- ▶ Turn the hand wheel [2] in – (minus) direction.
 - ✓ The seat back is inclining forward.

Seat adjustment forward/backward

- ▶ Lift the lever [3].
- ▶ Slide the seat forward or backward to reach the desired position.
- ▶ Release the lever [3] and let the seat pedestal snap in place.

Seat adjustment left/right

- ▶ Lift the lever [4].
- ▶ Slide the seat pedestal to the desired position to the left or right.
- ▶ Release the lever [4] and let the seat pedestal snap in place.

Driver's seat design B



Set driver's weight

There is damping built into the driver's seat that compensates for shock-like machine movements. For this damping to function optimally, the seat must be adjusted to the weight of the driver.

The driver's weight can be adjusted in 9 steps between 50 kg and 130 kg.



The handle for setting the weight must only be pushed downwards from above.

- ▶ Push the handle [1] down hard towards the end stop.
- ✓ The weight setting is adjusted upwards to its 50 kg home position.
- ▶ Push the handle [1] downwards and set the driver's weight.

Setting the slope of the backrest

- ▶ Lift the lever [2].
- ▶ Move the seat face forwards.
- ✓ The seat back is inclining backwards.
- ▶ Move the seat face backwards.
- ✓ The seat back is inclining forward.
- ▶ Release lever [2].

Seat adjustment forward/backward

- ▶ Lift the lever [3].
- ▶ Slide the seat forward or backward to reach the desired position.
- ▶ Release the lever [3] and let the seat pedestal snap in place.

Seat adjustment left/right

- ▶ Lift the lever [4].
- ▶ Slide the seat pedestal to the desired position to the left or right.
- ▶ Release the lever [4] and let the seat pedestal snap in place.

3.06 Using safety belt

⚠ WARNING

Driving without safety belt!

Serious injuries or death can occur if the machine brakes suddenly or tips over and the seat belt is damaged or not worn correctly.

- Only drive the machine when wearing the seat belt.
- Put on the seat belt correctly and do not twist it.
- Make a visual examination of the seat belt when putting it on.
- Have the seat belt immediately replaced by an authorized service provider:
 - If it is worn or damaged
 - After an accident
 - As a general rule, every 3 years



When putting on and taking off the seat belt, avoid pulling it jerkily or tightening it excessively.



Putting on belt

- ▶ Pass the seat belt closely over the hips.
- ▶ Adapt the length of the safety belt to your body size so as to ensure that your freedom of movement is not restricted.
- ▶ Insert the locking plate [1] into the belt lock [2].
- ✓ Seat belt is applied and locked.

Loosing belt

- ▶ Press knob at the buckle [2].
- ✓ Seat belt is released.
- ▶ Place the seat belt on the driver's seat or allow it to roll into the belt retainer.

3.07 Open and close engine hood

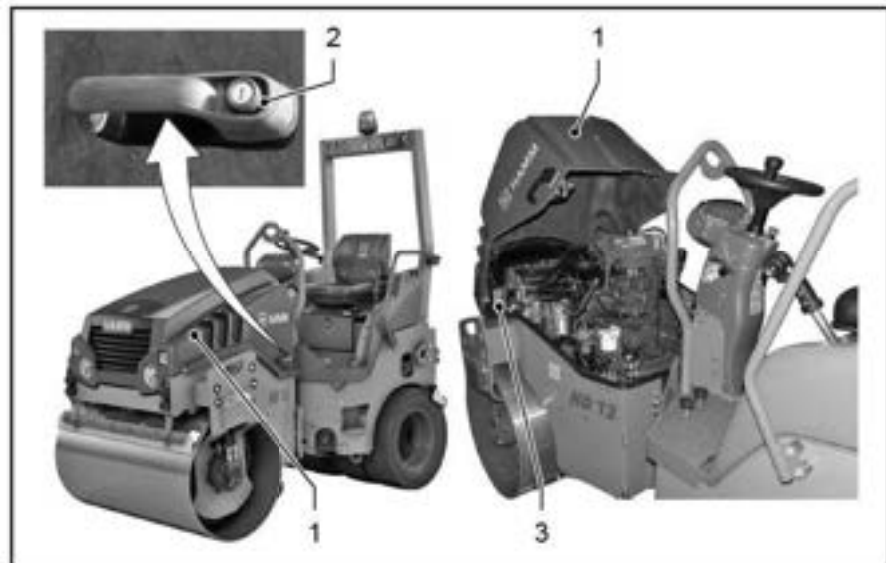

Opening the engine hood

- ▶ Use the ignition key in the lock on the handle [2] to unlock the engine hood [1].
- ▶ Press the push-button on the handle [2].
- ▶ Raise the engine hood [1].
- ✓ The engine hood is open.
- ✓ The engine hood is held in place by pneumatic springs [3].

Closing the engine hood

- ▶ Lower the engine hood [1] and push it into the lock.
- ▶ Use the ignition key in the lock on the handle [2] to lock the engine hood [1].
- ✓ The engine hood is closed.



The engine hood must be locked while the machine is operating.

3.08 On-board electrical system/battery isolation switch

NOTICE

Voltage spikes!

Damage or destruction of electrical components.

- Only interrupt the electrical circuit at the battery main switch when the engine is at a standstill and the electrical system is switched off.

The circuit to the minus terminal of the battery is interrupted at the battery isolation switch. All electric components will be off.

Battery isolating switch positions

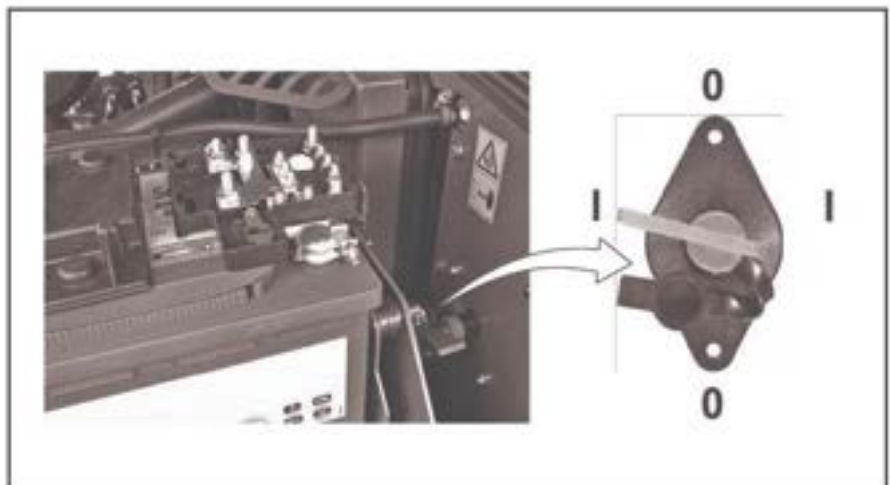

- Electrical circuit interrupted, on-board electrical system OFF – position **0** (key free)
- Electrical circuit closed, on-board electrical system ON – position **I** (key engaged)



The battery isolating switch is located inside the engine compartment. To actuate the switch, the engine hood must be opened.

As an option, the battery isolating switch can be operated via a Bowden wire at the machine side. The on-board electrical system can then be switched off without opening the engine hood.

3.09 Switching the electrical system on and off

Ignition key



The electrical system is switched on and off and the diesel engine started and stopped with the ignition key.

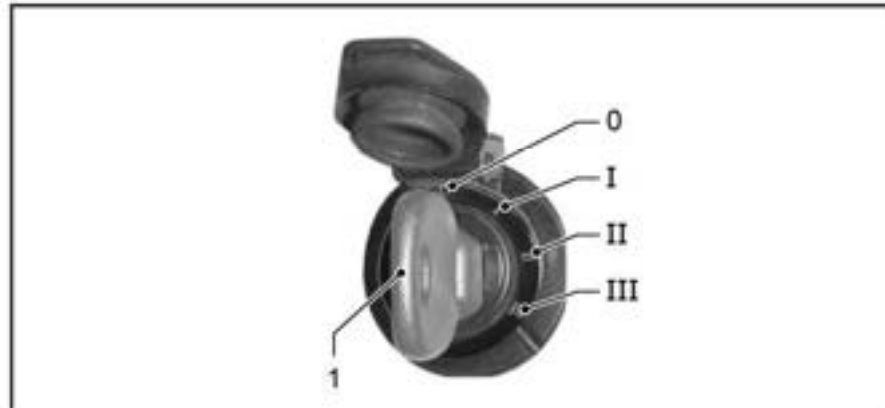

Switching on electrical system

- ▶ Turn ignition key [1] to position I.
- ✓ The electrical system is switched on.
- ✓ Functional control of warning and pilot lights
- ✓ Diesel engine remains switched off.

Switching off the electrical system

- ▶ Turn the ignition key [1] to position 0.
- ✓ The diesel engine is stopped.
- ✓ The electrical system is switched off.

3.10 Switching the signal horn and lighting on and off



When the lights are set to on for a longer period of time although the engine is stopped, the battery will be discharged quickly.

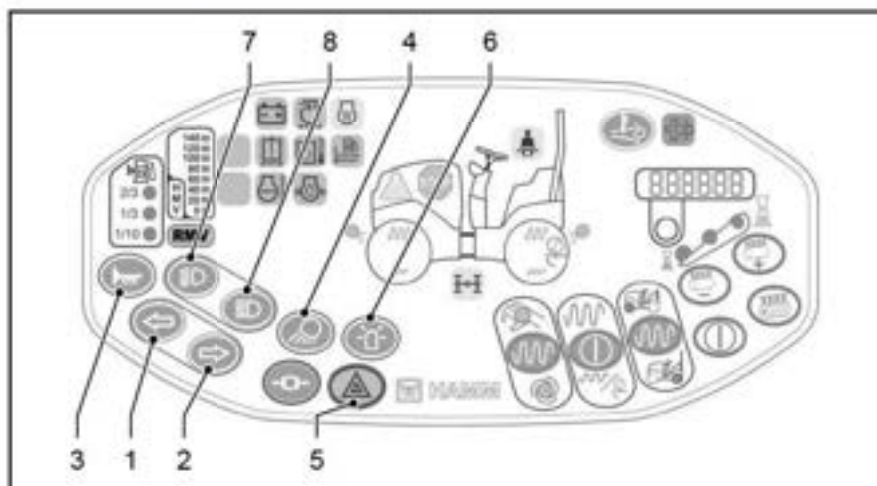

Actuating signal horn

Requirement: Electrical system is ON.

- ▶ Press the signal horn switch [3].
- ✓ A short acoustic signal sounds when a fault is detected.

Switching the hazard warning lights on and off

- ▶ Press switch [5].
- ✓ Switch [5] flashes: The hazard warning light is switched on.
- ▶ Press the switch [5] again.
- ✓ Switch [5] is not lit up: The hazard warning light is switched off.

Signalling left/right

Prerequisite: The electrical system is ON.

- ▶ Press switch [1] for signalling left.
- ▶ Press switch [2] for signalling right.
- ✓ The relevant switch [1/2] flashes: The turn signal light is switched on.
- ▶ Press the switch [1/2] again.
- ✓ Switch [1/2] is not lit up: The turn signal light is switched off.



If the light bulb in one of the direction indicators is defective, the indicator lights/switches flash rapidly. To guarantee road safety, the defective light bulb must be replaced.

Switching the parking light on and off

Prerequisite: The electrical system is OFF.

- ▶ Press switch [7].
- ✓ Switch [7] lights up: The parking light is switched on.
- ▶ Press the switch [7] again.
- ✓ Switch [7] is not lit up: The parking light is switched off.

Switching the driving light on and off

Prerequisite: The electrical system is ON.

- ▶ Press switch [7].
- ✓ Switch [7] lights up: The driving light is switched on.
- ▶ Press the switch [7] again.
- ✓ Switch [7] is not lit up: The driving light is switched off.



When it is set to on, the parking light will automatically change to driving light as soon as the electrical system is set to on.

When it is set to on, the driving light will automatically change to parking light as soon as the electrical system is switched off.

Switching the high beam on and off

The high beam switch [8] is not working.

Switching the work light on and off

Depending on the machine's configuration, the working light can consist of various components, e.g.

- front and/or rear working spotlights.
- Drum edge lighting.

Prerequisite: The electrical system is ON.

- ▶ Press switch [4].
- ✓ Switch [4] lights up: The work light is switched on.
- ▶ Press the switch [4] again.
- ✓ Switch [4] is not lit up: The work light is switched off.

Switching the rotating beacon on and off

Prerequisite: The electrical system is ON.

- ▶ Press switch [6].
- ✓ Switch [6] lights up: The rotating beacon is switched on.
- ▶ Press the switch [6] again.
- ✓ Switch [6] is not lit up: The rotating beacon is switched off.

3.11 Starting the machine

Requirement: Fill levels for the operating materials, for example fuel, water etc., are adequate.

Before starting the machine, check all functions and settings (see "Function tests before starting work").



The electrical system is switched on and off and the diesel engine started and stopped with the ignition key.

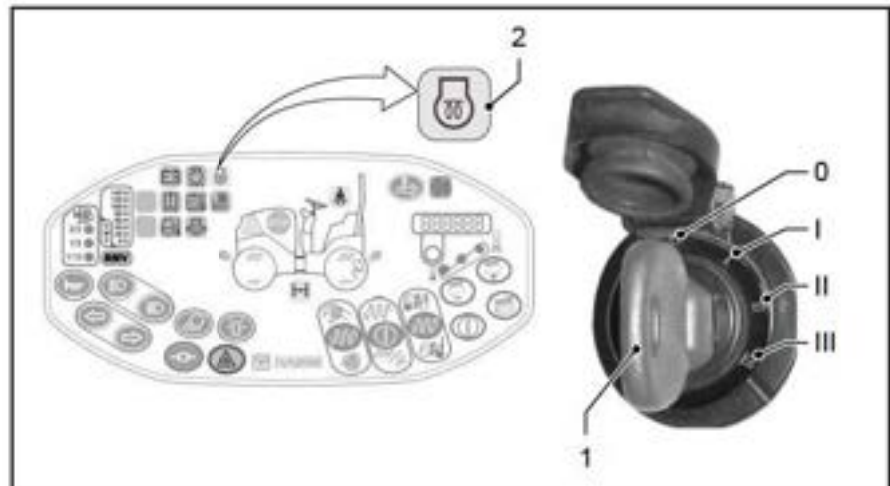

[0]	Electrical system OFF, diesel engine STOP	[I]	Electrical system ON
[II]	No function	[III]	Engine start



When the engine is at a standstill and the electrical system is switched on for a longer period (position I), the battery discharges rapidly.

Switching on electrical system

- ▶ Turn ignition key [1] to position I.
- ✓ Electrical system is ON.
- ✓ Functional control of warning and pilot lights
- ✓ Diesel engine remains switched off.

Cold start assistance/ preheating

The diesel engine needs to be preheated when it is cold. This step can be omitted when the engine is at operating temperature.

- ▶ Turn and hold the ignition key [1] in position II.
- ✓ The cold start assistance [2] pilot lamp is lit.
- ✓ The cold start assistance [2] pilot lamp goes out after a few seconds.
- ✓ Ignition key turns back to position I after releasing.
- ✓ The engine is ready to start.



When the starting temperature is reached, the indicator light switches off. Do not start the diesel engine before this.
Preheating is time controlled only. When the temperature is low, preheat twice if necessary.

Starting diesel engine

NOTICE

Damage of the starter!

Damage or destruction of the starter as a result of an excessively long start phase.

- Keep the ignition key not longer than 5 seconds in position III.
- If a starting attempt fails, make a fault diagnosis.

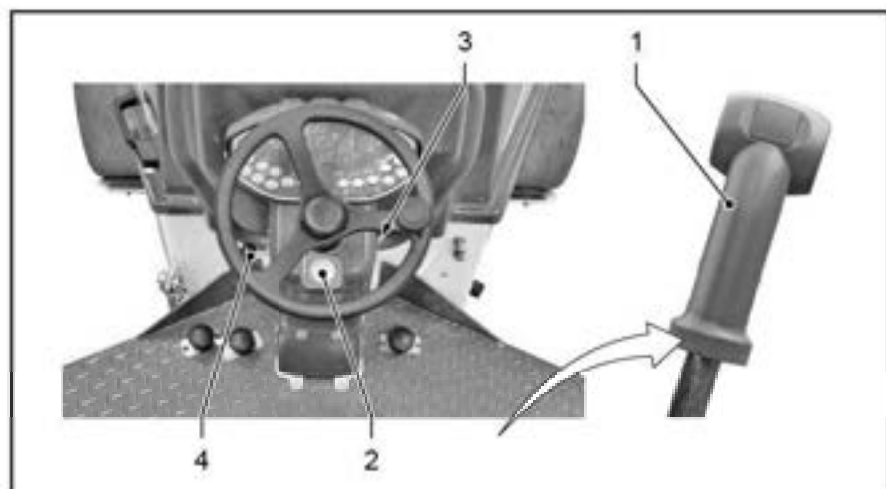

The starter is not connected to the starting switch unless the drive lever is in 0 position. This is the only way to start the diesel engine.

Conditions for starting the engine:

- The drive lever [1] is latched into the position 0.
- The EMERGENCY STOP [2] button is released.
- Internal power supply and electrical system are switched on:
 - Battery isolating switch in position I (circuit closed).
 - Turn ignition key [3] to position I or II.
- Cold starting device pilot light is off.

Starting diesel engine:

- ▶ Set the motor speed [4] to MIN.
- ▶ Turn the ignition key [3] to position III and hold it there until the diesel engine starts.
- ✓ Diesel engine starts.
- ✓ Ignition key turns back to position I after releasing.



3.12 Driving

▲ WARNING

Braking delay!

Severe injury or death due to a longer braking distance at a low operating temperature and especially when freezing.

- After starting the diesel engine, wait for a few minutes before driving off until the machine reaches the operating temperature.
- Whilst the hydraulic oil temperature warning light is on, drive the machine at only a moderate speed.

▲ WARNING

Full braking!

Severe injuries caused by a strong braking force.

- Drive with foresight and adjust your speed to the environmental and weather conditions.
- In case of visible obstacles reduce speed in good time.

NOTICE

Contamination!

Material damage to scrapers and other parts of the machine as a result of soiled drums or tires.

- Before driving off, ensure that there are no clumps of earth sticking to the drums or tyres.
- Park machine on boards or dry gravel if there is a risk of frost.



Operate the machine sitting on the operator's seat only! Multiple safety systems prevent the machine from being driven further as soon as the driver stands up from his seat.

3.12.01 Seat contact switch

Machine may only be operated from the operator platform. In order to ensure this, the machine is equipped with a seat contact switch. If the driver rises from his seat while driving, the seat contact switch is activated and the machine is braked after a delay.

▲ WARNING

Fast automatic braking!

Delayed, fast braking of the machine that starts automatically can lead to serious injuries or death.

- Only drive the machine when seated.
- Do not use the function of the safety switch to stop the machine.
- Brake and stop the machine with the driving lever.

Operator's seat monitoring

- ▶ If the operator does not remain seated while driving, an audible
✓ signal is heard immediately.

- ▶ If the driver fails to react,
- ✓ the machine will be braked until it stops after a total of **3 seconds**, and the working functions will be set to off.
- ✓ The diesel engine continues running.

Braking is not initiated if the driver returns to his seat within 2 seconds of leaving it.

If the machine is braked by the safety switch, the machine has to be returned to its home position before operation.

Bring the machine into the home position - drive on after the delayed braking.

Prerequisites:

- Machine at a standstill, after the delayed braking.
- Driver sitting on the seat again.
- Diesel engine is running.
- ▶ Move drive lever in position 0.
- ✓ The work functions are active again.

3.12.02 Adjusting the engine speed



The speed of the diesel engine can be adjusted between idling speed and max. speed using the adjusting lever.

The lever engages at idling speed and at max. speed, and can be positioned anywhere between these detent positions.

- Idling speed – MIN
- Max. speed – MAX



The vibration frequency is coupled to the engine speed. The adjustment of the engine speed will elements in the vibration frequency (see Technical Data).

3.13 Driving in normal operation

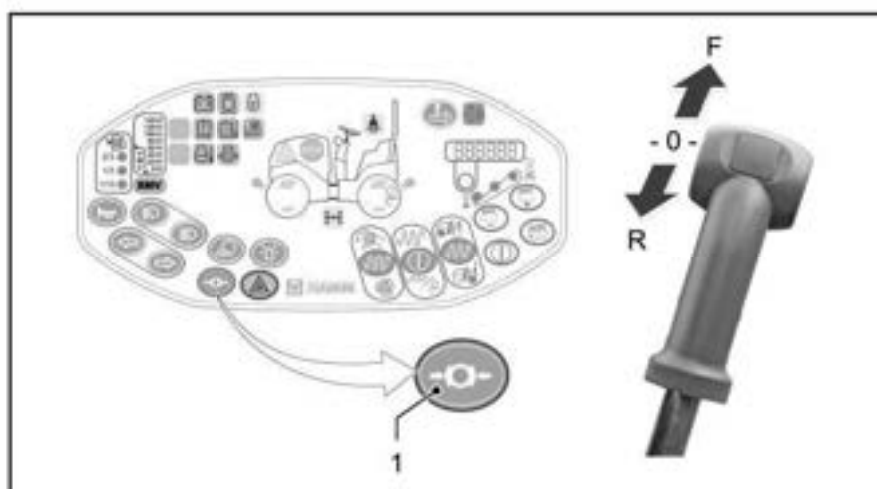

Make ready to drive/ release parking brake

Requirement: Diesel engine running, drive lever in position 0

- ▶ Press the parking brake switch [1].
- ✓ The parking brake switch [1] is not illuminated.
- ✓ Machine is ready to start.

Driving forwards

- ▶ Preselect the motor speed.
- ▶ Move the drive lever in the F direction.
- ✓ The machine travels forwards. The final speed depends on the deflection of the drive lever and on the selected motor speed.

Driving backwards

- ▶ Preselect the motor speed.
- ▶ Move the drive lever in the R direction.
- ✓ The reversing lights are on.
- ✓ The machine travels backwards. The final speed depends on the deflection of the drive lever and on the selected motor speed.



For versions equipped with a back-up alarm, an audible signal is heard as soon as the drive lever is in position R.

Reversing

- ▶ While driving, slowly move the drive lever via the 0 position in the opposite direction.
- ✓ The machine brakes to a halt and accelerates in the opposite direction, depending on the deflection of the drive lever and on the motor speed selected.

Four-wheel blocking (option)

The machine is equipped with a hydraulic four-wheel drive, which is driven by a variable displacement pump. The blower output is fed to both hub motors in the drum. The driving power of the machine is used for the locomotion according to the surface conditions and the corresponding drift. If the coefficient of friction between the ground and a drum drops to the extent that a drum starts slipping, the entire pump oil flow will empty across the hub motor of the turning drum, thereby substantially reducing the tractive force of the still-standing hub motor.

The switching on of the four-wheel blocking triggers the automatic division of the oil flow. Every gear hub motor is now provided with a separate oil flow, which ensures a constant traction force for each roller drum without pressure compensation.

The four-wheel blocking can be switched on when driving on difficult surfaces, as long as both drums are still turning.

If the machine is at a standstill while the drum is still turning, the drive lever should be placed in the 0 position before the four-wheel blocking is applied. To drive away, slowly move the drive lever until both roller drums are being propelled. Once the machine is driving, the four-wheel blocking can be switched off again.



When the machine is loaded, the all-wheel lock must be applied before driving onto the loading ramp.

Switching on the all-wheel lock

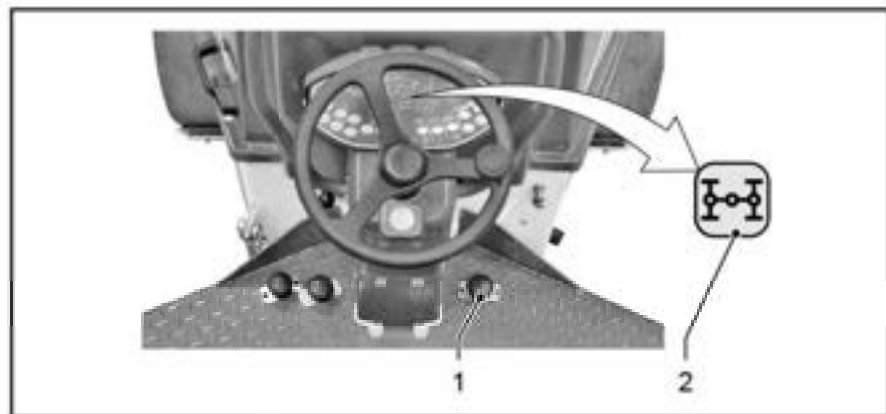

- ▶ Step on the foot switch [1].
- ✓ The all-wheel lock is activated.
- ✓ The activated all-wheel lock is shown by indicator light [2] on the operator control panel.



The all-wheel lock is applied only as long as the switch is pressed.



3.14 Stopping the machine in normal operation

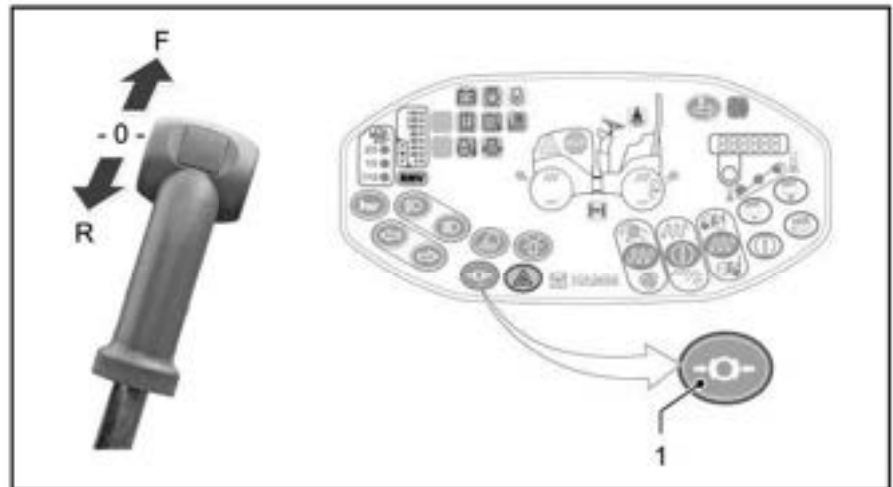

- ▶ Quietly and steadily move the drive lever to position 0 and stop it/let it click into place there.
- ▶ Set the motor speed to idle (MIN).
- ✓ The hydrostatic transmission brakes the machine to a standstill.
- ✓ The parking brake has not been activated.

Activating the parking brake

- ▶ Press the parking brake switch [1].
- ✓ The parking brake is activated.
- ✓ The parking brake switch [1] lights up.



The parking brake can only be released if the drive lever is engaged in position 0.

3.15 Machine is stopped in the EMERGENCY STOP state

▲ WARNING

Full braking!

Stopping the machine suddenly can lead to serious injuries or death.

- Only use the EMERGENCY STOP in the event of danger.
- Do not use the EMERGENCY STOP as the service brake.

NOTICE

Incorrect performance of an EMERGENCY STOP!

Material damage to electronic or mechanical components of the machine as a result of incorrect performance of an EMERGENCY STOP.

- Always use the EMERGENCY STOP function to switch off the machine in the event of danger.

In case of danger, actuate the EMERGENCY STOP

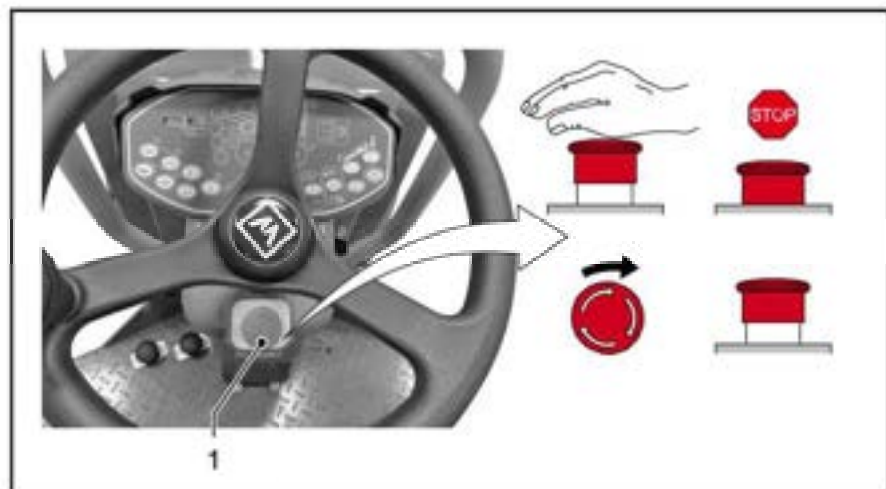

In an emergency, the EMERGENCY STOP brings the machine to a controlled stop and switches it off. Using the EMERGENCY STOP is the only way to guarantee that all operating functions will be disabled immediately without causing any further danger to driver, the machine or the environment.

- ▶ Press down hard on the EMERGENCY STOP button [1].
- ✓ The machine will disable all operating functions automatically and
 - stop the travel drive immediately.
 - switch the diesel engine off.
 - apply the brakes.
- ▶ Switch off the electrical system using the ignition key.
- ▶ Engage the drive lever in position 0.
- ▶ To release the EMERGENCY STOP [1]: Turn the button clockwise until the lock is released.

Restarting the machine after an EMERGENCY STOP



- ▶ Switch on the electrical system using the ignition key.
- ✓ The diesel engine can be started.

3.16 Stopping the machine because of a fault

NOTICE

Severe malfunctions!
 Damage or destruction of machine components caused by continuing operation despite serious faults.

- When a serious fault is indicated, immediately stop the machine at a safe position outside the danger zone.
- Determine and remove the cause of the malfunction.
- Do not use the machine again until the fault has been rectified.

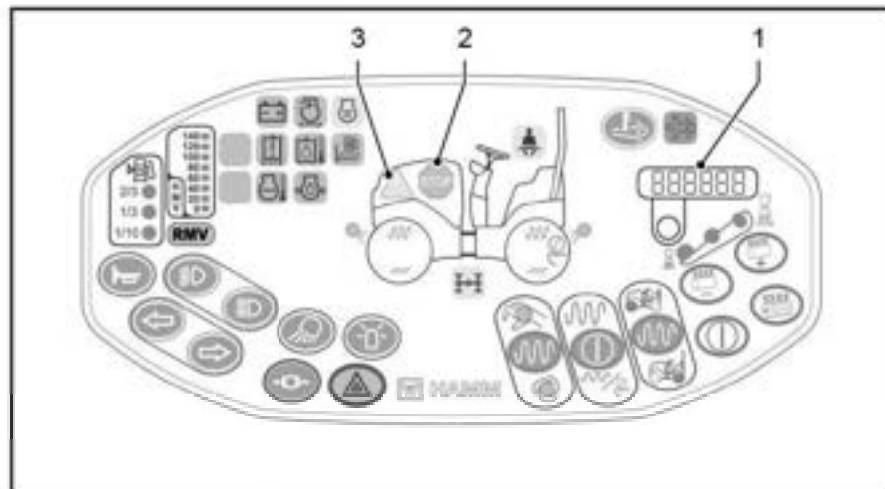

Serious fault

In the event of a serious fault:

- ✓ A permanent acoustic signals sounds.
- ✓ At least one warning light lights up.
- ✓ The system info [1] displays an error code.
- ✓ The STOP warning light [2] flashes.
- ▶ Stop using the machine.
- ▶ Park the machine out of the danger zone.
- ▶ Switch off the diesel engine immediately.
- ▶ Rectify the cause immediately.

i Write down the error code indicated. If you cannot correct the error yourself, please contact the customer service.

The STOP symbol appears when:

- Hydraulic oil temperature is too high
- Engine/coolant temperature is too high
- Coolant fill level is too low
- Engine oil pressure is too low/too high
- Water in diesel (water sump fuel prefilter)

Note on a fault

If there is a deviation from the normal operating status:



- ✓ The indicator light lights up [3].
- ✓ An acoustic signal sounds briefly.
- ✓ At least one warning light lights up.
- ✓ The system info [1] displays an error code.
- ▶ Further operation of the machine is admissible for a short period of time.
- ▶ Park the machine out of the danger zone.
- ▶ Rectify the cause of the fault without delay, no later than at the end of the work shift.



No further operation of the machine is admissible unless the error messages indicated do not cause any immediate risk to the safety of people, machinery or environment.

3.17 Driving with the dynamic compaction system

▲ WARNING

Reduced road adhesion!

Serious injuries or death through the machine tipping over because of reduced ground adhesion.

- Never switch on the dynamic compaction system when traveling across a slope or on hard ground.

▲ WARNING

Explosion!

Severe injury or death by gas explosion.

- Before switching on vibration, make certain that no gas line is buried in the ground you will be working on.

NOTICE

Vertical oscillations caused by vibration!

Collapse or damage at buildings or on lines laid in the underground.

- Do not switch on vibration system near buildings!
- Prior to switching on the vibration function, it must be ensured that there are no lines laid in the underground in the vibration area.

Vibration

In the vibration mode the roller drum is shifted to vertical oscillations. These hammering impacts produce a manifold increase in the compaction force of the machine.

Effect on the environment:

Vibration oscillations can spread in the ground over a wide area. They are generated in circles around the roller drum and effect also the deeper ground. This may cause a damage to buildings or pipe systems under the machine.

Amplitudes/frequency:

The vibration system uses an amplitude. The frequency depends on the preselected motor speed.

Oscillation

In the oscillation mode the roller drum is shifted to tangential oscillations. The compression of the material to be compacted is conducted by flexing movements.

Effect on the environment:

Oscillation vibrations are developed predominantly on the surface of the ground and spread only in front of the roller drum and on its rear. Thus the damaging force is reduced considerably.

Amplitudes/frequency:

Oscillation uses a tangential amplitude. The frequency depends on the preselected motor speed.

3.17.01 Switching the compaction system on and off

The dynamic compaction system is deactivated every time the engine is started.

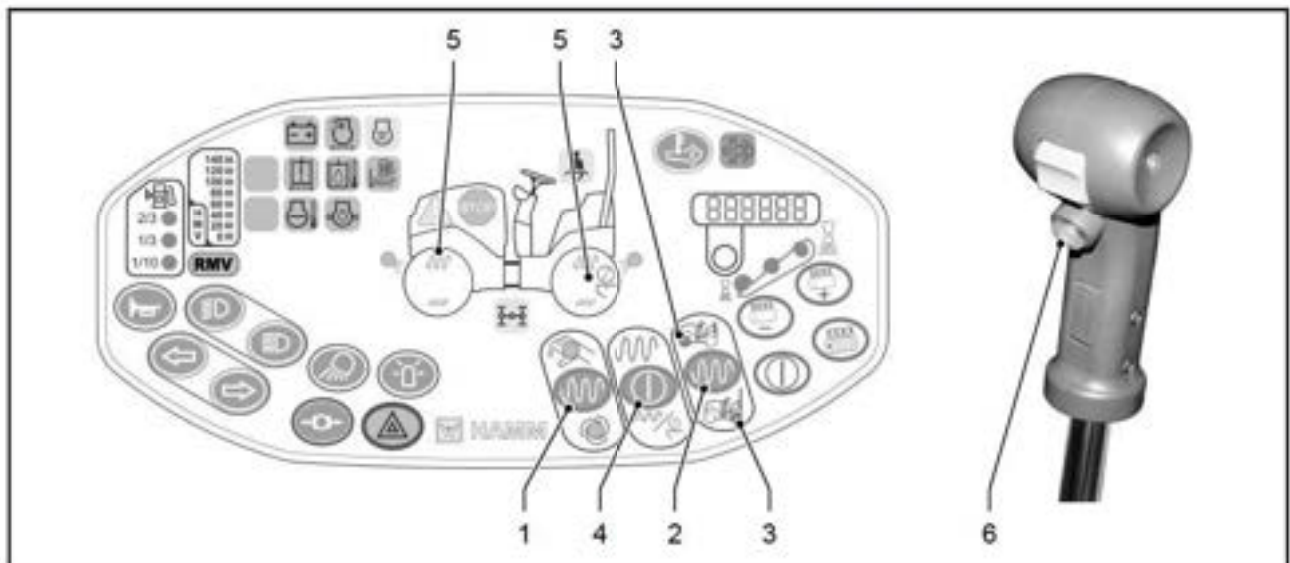

No.	Switch/symbol	Meaning
[1]		Operating mode switch
		Manual
		Automatic
[2]		Preselect the drum
[3]		Indicator LED for the preselected drum
[4]		Activate the drum
[5]		Vibration/oscillation symbols
[6]		Dynamic compaction system ON/OFF switch

Preparing for working with dynamic compaction system

Requirement: Electrical system ON

Selecting manual operating mode

- ▶ Press switch [1].
- ✓ LED *Manual* lights up green.
- ✓ Use the switch [6] at the drive lever to set the dynamic compaction system to ON or OFF.

Selecting automatic operating mode

- ▶ Press switch [1].
- ✓ LED *Automatic* lights up green.
- ✓ The dynamic compaction system is switched on/off automatically depending on the vehicle speed. The dynamic

compaction system is switched off when at low or high speed.



Always preset manual mode when restarting the machine.

Preselect the roller drum

The dynamic compression of the roller drums can be performed both in combination and single for every roller drum.

- ▶ Press switch [2].
- ✓ The pilot LEDs [3] of the preselected roller drums light up in green.

To select or unselect the roller drums either individually or in combination, repeatedly press the switch [2].

Activate the roller drum

- ▶ Press switch [4].
- ✓ The vibration/oscillation icon [5] is lit.
- ✓ the selected roller drum is ready for operation with vibration/oscillation.



The opportunities available for activation depend on the configuration of your machine:

- V: Front and/or rear vibration.
- O: Rear oscillation.
- T: Rear tyres (no dynamic compaction).

Setting drum in vibration

Requirement: Diesel engine is running.

- ▶ Press switch at drive lever [6].
- ✓ In accordance with the settings, the compaction system works immediately (manual) or when driving starts (automatic).

Switch off vibrations

- ▶ Press the switch on the drive lever [6] again.

Activating/deactivating the compaction system

3.18 Driving with water sprinkling system

After each engine start water sprinkling system is deactivated.

The water sprinkling system wets the drums/tyres and the edge pressure and cutting device with water. The wetting prevents that bitumen sticks on roller drums/tyres when laying blacktops. This is the way to make a neat and even covering.

An electric water pump supplies the water sprinkling system with water. The built-in automatic sprinkling unit adjusts the water consumption to match the conditions of use optimally. A multilevel automatic interval system determines the minimum use of water for optimum moisturing, using a combination of spray quantity and pump pause time. The water pump can also be switched manually to continuous operation at any time.



The sprinkling control is switched off at a road speed of less than 0.5 km/h (0.3 mph). Continuous operation is still possible in this case.

Sprinkling the roller drum/tyres

Requirement: Diesel engine is running, water sprinkling system is activated.

- ▶ When the driving speed exceeds 0.5 km/h (0.3 mph) the sprinkling is switched on.
- ▶ When the machine is at a standstill, the sprinkling is switched off.

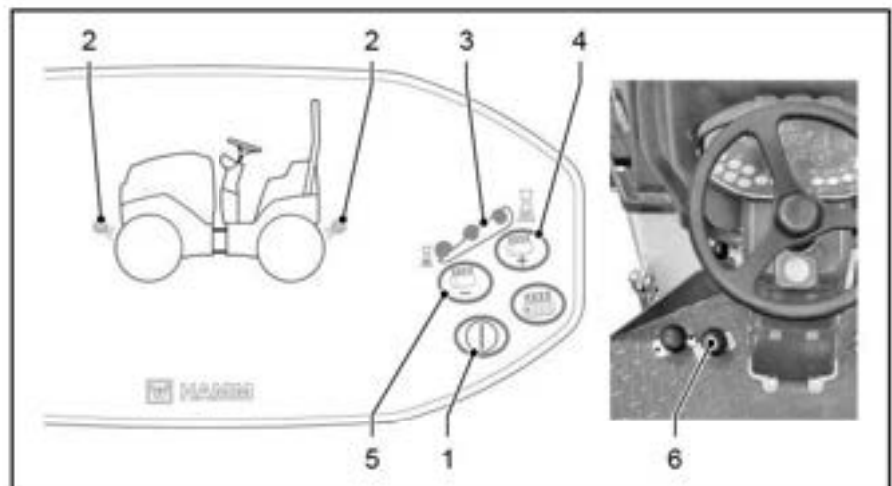

Switching the water-sprinkling system on and off

Activating the water-sprinkling system

Prerequisite: Electrical system is ON

- ▶ Press the switch [1].
- ✓ The illuminated dots [3] show the current sprinkling stage.
- ✓ The indicator LED [2] is on when the sprinkling system is switched on via the automatic interval system.

**Deactivating water sprinkling system**

- ▶ Press the switch [1] again.
- ✓ Water sprinkling system is deactivated.
- ✓ Luminous spots [3] are off.
- ✓ Pilot LED [2] is permanently off while driving.



Ensure that the drums/tyres are wetted evenly.

Selecting sprinkling stage

When the water sprinkling system is activated, the water consumption can be regulated areas using sprinkling stages.

Requirement: Water sprinkling system is activated.

- ▶ Press switch [4] + (plus).
- ✓ Sprinkling increases by one stage.
- ✓ The luminous spots [3] show the current sprinkling stage.
- ▶ Press switch [5] - (minus).
- ✓ Sprinkling decreases by one stage.
- ✓ The luminous spots [3] show the current sprinkling stage.
- ▶ Press and hold the foot pedal [6].
- ✓ Water sprinkling takes place for as long as the foot pedal is held down.
- ✓ Sprinkling also is possible when the machine is stationary.

Switching continuous water sprinkling on and off

3.19 Driving with additive sprinkling system

The additive sprinkling moistens the tyres with a separating compound. The wetting prevents that bitumen sticks on tyres when laying blacktops. This is the way to make a neat and even covering.



The frequency of sprinkling depends on the temperature of the tyres. Cold tyres must be moistened more often than warm ones. Prior to driving on hot blacktops take care that the running surfaces of the wheels are clean and sufficiently moistened.



The emulsion may only be mixed of parting agent concentrate and water according to the indications of the parting agent producer (Observe regulations for environment protection).

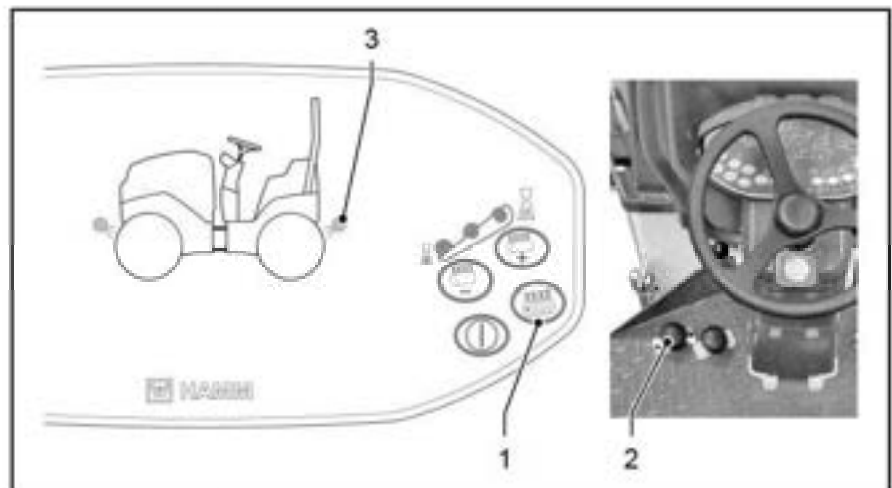

Switching the additive-sprinkling system on and off

Prerequisites:

- Version of the machine as a combination roller
- Electrical system ON
- No chip spreader mounted as an additional device.
- ▶ Press and hold the switch [1] or foot pedal [2].
- ✓ Additive sprinkling takes place for as long as one of the switches is held down.
- ✓ When the switch is pressed [1]: Indicator LED [3] on.
- ▶ Release the switch [1] or foot pedal [2].
- ✓ Additive sprinkling stops.
- ✓ The indicator LED [3] is off.

3.20 Track offset

Compacting work along kerbs or similar borders cannot be carried out, or only in a limited way, without track movement of the drums. A track adjustment especially developed for this problem enables the machine to drive very precisely along such problem areas.

Adjust track movement

▲WARNING

Unintentional movement of the machine!

Severe injury or death by unexpected machine movements during readjustment.

- Do not perform any readjusting work unless the engine is stopped and the ignition switched off.
- Park the machine on safe ground, i.e., Flat and horizontal ground with sufficient bearing capacity.
- Secure machine against rolling away.

NOTICE

Wrong performance of track offset readjustment!

Damage to the steering system due to wrong track offset readjustment.

- Do not use any lever tool (e.g., erection bar, other bars) for readjusting the track offset.
- The track offset must only be adjusted at the articulated joint console, never at any other components of the steering system.

NOTICE

Sharp-edged tools!

Damage to paint work when using unsuitable tools.

- Do not apply any sharp-edged tool to a painted surface when readjusting the track offset.

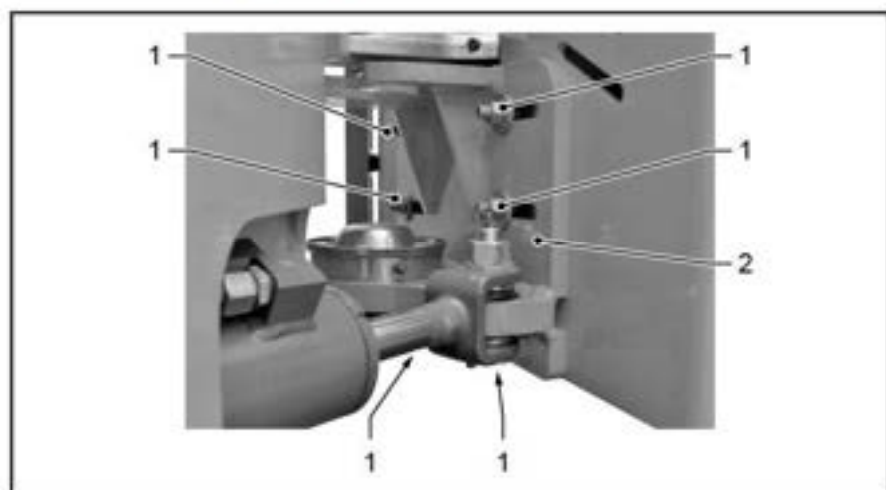

- ▶ Remove any steering angle before parking the machine.
- ▶ Switch off diesel engine and remove ignition key.



- ▶ Loosen the 6 × hexagon nuts [1] at the articulated joint console by a maximum of two turns.
- ▶ Apply a piece of squared timber to the side of the console [2].
- ▶ Readjust the track offset to the right or left by giving hammer blows.
- ▶ Tighten the 6 × hexagon nuts [1].



When there is no track offset (roller drums/tyres in a straight line one behind the other), the screw joints are in contact with the elongated holes of the console on the left. The front roller drum can be offset steplessly to the right by shifting.

3.21 Adjusting scrapers

The scrapers remove dirt adhering to the surfaces of the drums/tyres.

For transport driving, move the scrapers away from the drums/tyres. This prevents premature wear.

 Rinse out dirt embedded between drums/tyres and scrapers with a water jet. Remove any extremely stubborn dirt with a spatula or similar tool.

▲ CAUTION

Spring mechanism under tension!

Injury when caught and pinched.

- Do not put your hands or fingers between scraper and roller drum/tyre when applying or lifting off the scrapers.

3.21.01 Rigid roller drum scraper



The scrapers are constantly rubbing against the roller drums. They are pressed against the roller drums with spring force and cannot be lifted up.

3.21.02 Upper folding roller drum scraper

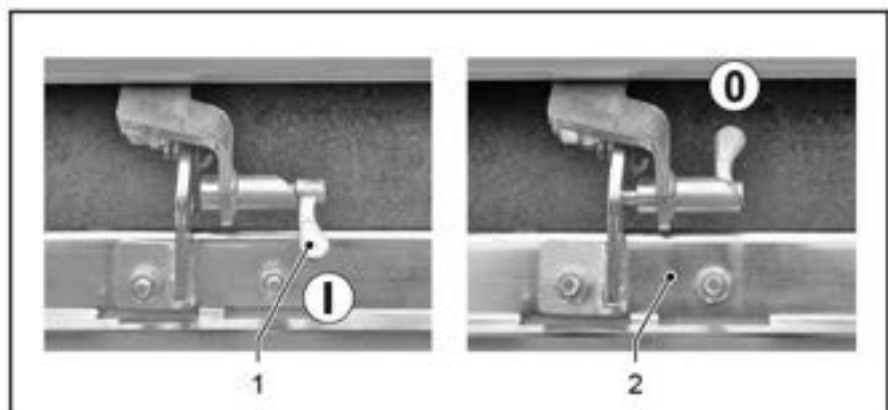

Attach scraper

- ▶ Switch off diesel engine and remove ignition key.
- ▶ Turn stop lever [1] to I position.
- ✓ The scraper folds down to the roller drum/tyre.

Moving the scraper away

- ▶ Switch off diesel engine and remove ignition key.
- ▶ Turn stop lever [1] to 0 position.
- ▶ Lift the scraper bracket [2] until the catch latches in.

3.21.03 Lower folding roller drum scraper

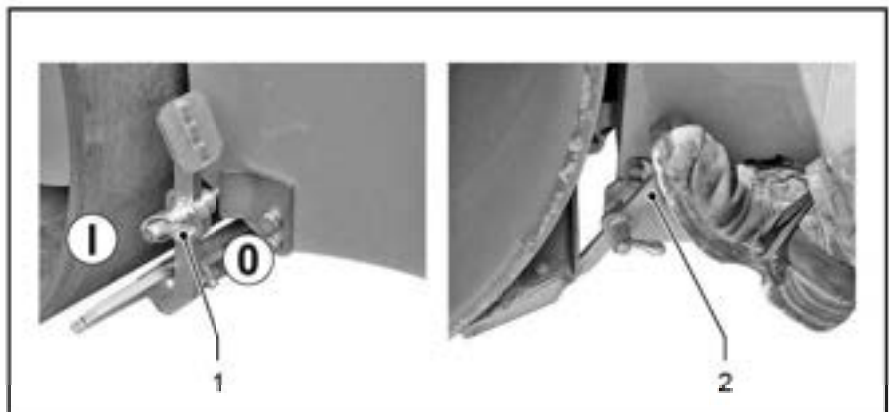

Attach scraper

- ▶ Switch off diesel engine and remove ignition key.
- ▶ Turn stop lever [1] to I position.
- ✓ The scraper folds up to the roller drum.

Moving the scraper away

- ▶ Switch off diesel engine and remove ignition key.
- ▶ Turn stop lever [1] to 0 position.
- ▶ Press the pedal [2] until the catch latches in.

3.21.04 Scraper tyres

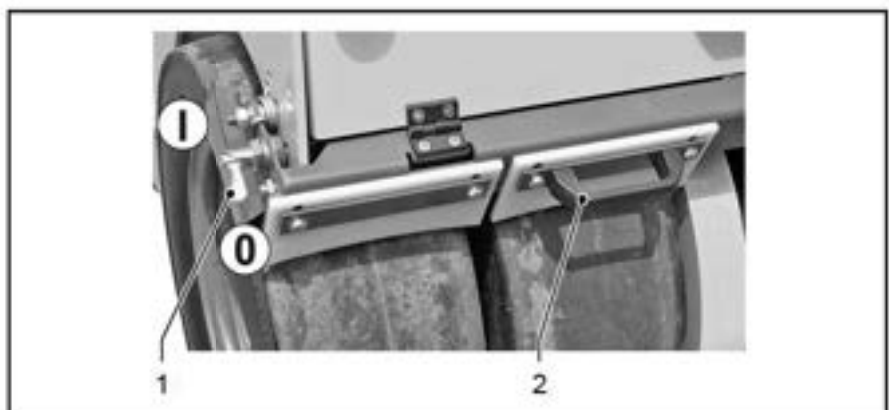

Attach scraper

- ▶ Switch off diesel engine and remove ignition key.
- ▶ Turn stop lever [1] to I position.
- ✓ The scraper folds down to the roller drum/tyre.







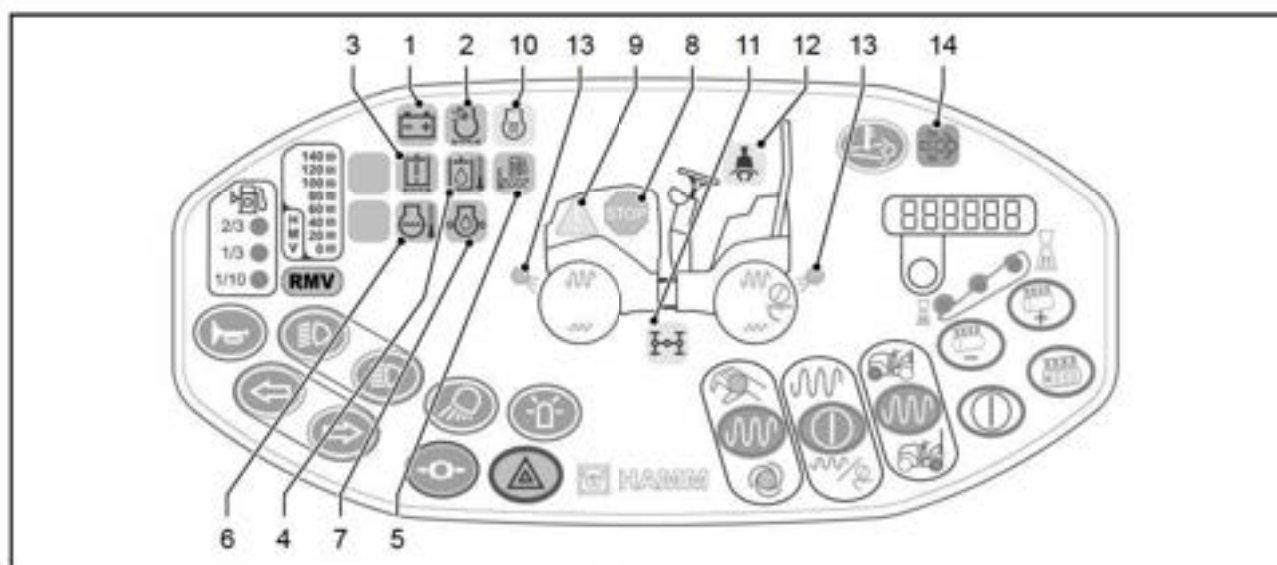

Moving the scraper away







- ▶ Switch off diesel engine and remove ignition key.
- ▶ Turn stop lever [1] to 0 position.
- ▶ Lift the scraper bracket [2] until the catch latches in.

3.22 Operation monitoring

Control panel – warning and indicator lights



No.	Symbol	Warning and indicator light	Status	Meaning/measure
[1]		Charge current (battery)	Flashes red	No charge current: Check the electrical system. Request assistance from customer service.
[2]		Air filter	Flashes red	The air filter cartridge is contaminated. Check the air filter.
[3]		No function		
[4]		Hydraulic oil temperature	Flashes red	Hydraulic oil temperature is high or the hydraulic oil has overheated. Switch off the engine, request assistance from customer service if necessary.
[5]		No function		
[6]		Engine temperature	Flashes red	Engine temperature is high or the engine has overheated. Switch off the engine, check the coolant fill level, check the radiator.
[7]		Engine oil pressure	Flashes red	Engine oil pressure is too low. Check the engine oil fill level.
[8]		Serious fault	Flashes red	Indicates a serious fault. At least one warning light is flashing and an error code

No.	Symbol	Warning and indicator light	Status	Meaning/measure
				is displayed. Stop using the machine!
[9]		Warning, notification, fault	Lights up yellow	Deviation from the normal operating status. At least one warning light is flashing and an error code is displayed.
[10]		Cold start assistance	Lights up yellow	Lights up during preheating. Goes out once the start temperature has been reached.
[11]		No function		
[12]		Seat belt monitoring device (optional)	Lights up yellow	Lights up when the seat belt is not being used. Put on the seat belt!
[13]		Water sprinkling	Lights up yellow	Lights up when the water-sprinkling system or additive-sprinkling system is switched on.
[14]		No function		

3.22.01 Control panel – fill level control indicator

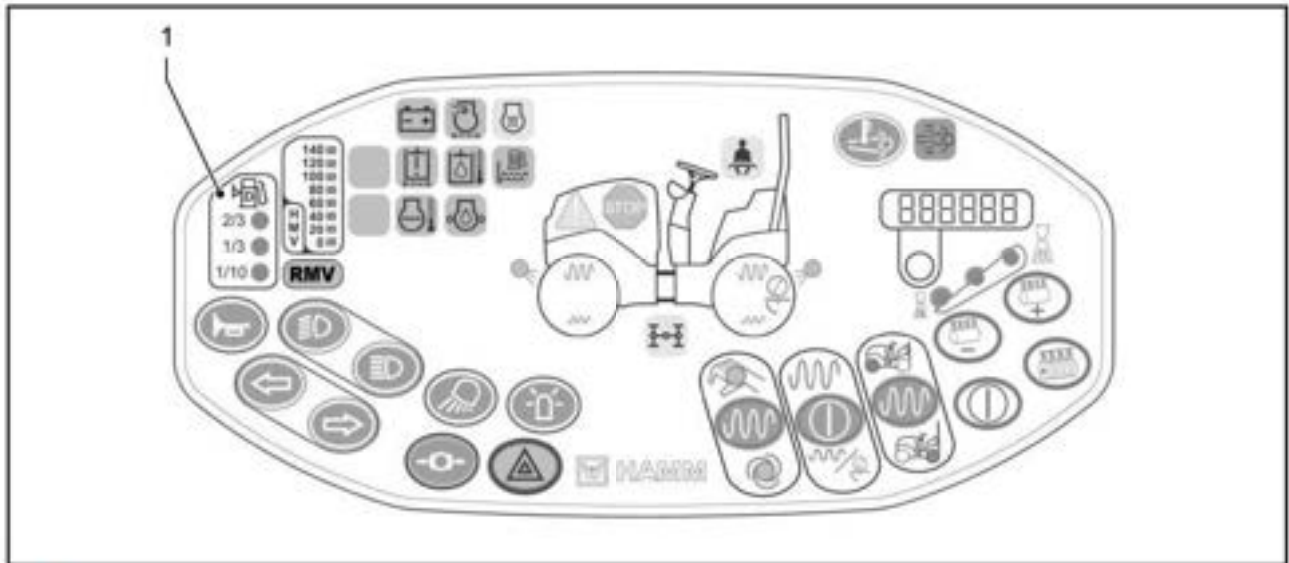

The filling levels in the service fluid tanks are indicated by luminous spots. One or more luminous spots light up according to the filling level.

No.	Symbol	Indicator	Status	Meaning/measure
[1]		Fuel fill level	lights up green	Fuel available
			flashes green	Fuel fill level between 2/3 and 1/3: Top up the fuel.
			flashes yellow	Fuel fill level below 1/10: Top up the fuel.

3.22.02 Control panel – info display/system info

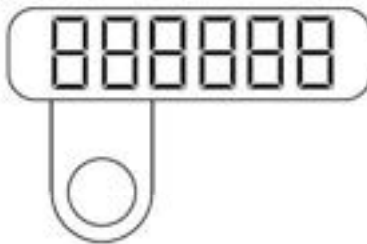

The driver can use this display unit to access information about the machine status, settings and system messages.

In the "System info" menu, you can choose between two levels by pressing and holding the switch.

Within the levels, you can change between various displays by briefly pressing the switch.

Level 1

- **Operating hours**
After the electrical system is switched on, the operating hours of the machine are shown in the display field. Maintenance work has to be carried out according to the accumulated operating hours.
- **Engine speed**
No indicator.
- **Asphalt temperature**
No indicator.
- **Diagnostics code**
A short acoustic signal sounds when a fault is detected. The display shows all the existing faults one after the other in the form of diagnostic codes.

→ Press and hold the switch to change to level 2.

Level 2

- **Roller type** e.g. HD 10 VV
- **Dashboard software version**
- **Compaction computer software version**



3.23 Switching diesel engine off

Requirement: Diesel engine is running.

- ▶ Latch driving lever in position 0.
- ▶ Fully lower attached accessory equipment.
- ▶ Switch off accessory equipment.
- ▶ Apply parking brake.
- ✓ Parking brake is applied.
- ✓ Diesel engine is running in idle speed.
- ▶ Allow the diesel engine to continue to idle for 1 to 2 minutes.
- ▶ Turn ignition key to position 0.
- ✓ Diesel engine is switched off.
- ✓ Electrical system is switched off.



3.24 Shutting down and leaving the machine safely

▲ WARNING

Unintended machine movement!

Severe injury or death due to unexpected machine movements.

- The driver may only leave the machine when it has been properly and safely shut down.
- Observe the road traffic regulations.
- Park the machine on safe ground, i.e., flat and horizontal ground with sufficient bearing capacity.
- Secure machine against rolling away.

Prior leaving the machine

- ▶ Switch off the diesel engine.
- ▶ Apply parking brake.
- ▶ Latch the seat console in the centre of the machine.
- ▶ Pull off the ignition key.
- ▶ Switch off the machine, using the main battery switch.
- ▶ Lock the instrument panel covering, as well as all cladding covers.
- ▶ Use suitable precautions (e.g., parking chock) to secure the machine against rolling away in addition when parking on an uphill or downhill gradient.

3.25 Towing the machine

An inoperable machine can be towed by another vehicle for short distances.

For distances longer than 500 m, the machine must be loaded for further transport.

▲ WARNING

Spring-operated brake out of function!

Severe injury or death due to machine rolling away.

- Prevent the machine from rolling away with chocks before releasing the spring-operated brake.
- Do not attach the machine for towing unless at the points intended for this.
- Use a towing vehicle with enough pulling power.
- Tow machine only with low speed 1 km/h (0.6 mph).
- Only tow the machine for short distances (max. 500 m).



Towing of the machine requires sufficient knowledge of the functioning of the hydrostatic transmission and the operation of the spring-operated brake.

Only allow towing to be performed by persons with towing experience, who have been informed of the dangers.

Necessary towing tool

- **Towing bar**
Use a towing bar with adequate pulling power (at least the operating weight of the machine) for a normal case of use on a flat surface with the spring-operated brake released.



To recover the machine from hazardous situations, the machine can be lifted (see Loading and transporting). Alternatively, the machine can be pulled out of hazardous situations using towing ropes or towing chains (pulling power at least double the machine's operating weight).

When using towing ropes or chains:

▲ WARNING

Towing equipment live!

Serious injuries or death due to tensioning or tearing towing equipment.

- Keep your distance from towing equipment (at least the length of the towing rope or chain).
- The tractive force of the towing equipment must correspond to at least double the operating weight of the machine.
- Keep the length of the towing equipment as short as possible in accordance with the rescue situation.

3.25.01 Preparing the machine for towing

NOTICE

Uneven distribution of the tractive force!

Material damage to the machine caused by uneven application of force if traction mechanisms are attached incorrectly.

- Only attach the machine to the points intended and marked for it.
- If no central suspension point (e.g. suspension eyelet) is available, the towing tools must be attached in pairs on both sides at the marked lashing points/towing points on the machine.
- The towing must only take place forwards/backwards in the machine's direction of travel.



- ▶ Move the drive lever into the zero position.
- ▶ Press the parking brake switch.
- ✓ The drive lever is blocked.
- ✓ Parking brake is active.
- ✓ The transmission is not active.
- ▶ Shut down the diesel engine, if still functional.
- ▶ Use parking chocks to secure machine against rolling away.
- ▶ Replace damaged pipes and hoses from which oil leaks before towing (environment protection).
- ▶ Attach towing tools to the lashing points [1] of the machine and the towing vehicle.
- ▶ Depressurize the hydraulic system. (see "Depressurize the hydraulic system").
- ▶ Releasing spring-operated brake (see "Release spring-operated brake").

3.25.02 Depressurize the hydraulic system



The hydraulic system must be depressurized before towing starts.

Only if the oil flow can circulate without pressure in the hydraulic system, can the machine be towed.



Separating the hydrostatic drive power train

- ▶ Loosen lock nut [1] at the drive pump [3].
- ▶ Screw in the locking screw [2] until the screw end flushes with the lock nut.
- ✓ Frictional connection is interrupted: Machine is ready to be towed.

Restoring the traction for the hydraulic travel drive

- ▶ Unscrew the stud screw [2] as far as it will go.
- ▶ Tighten the lock nut [1].
- ✓ Traction is established: The machine is ready for the repair work.

3.25.03 Releasing spring-operated brake





The spring-operated brake may only be disabled when:

- The engine is defective, or
- The hydraulic system is defective

Putting spring-powered brake out of operation

- ▶ Loosen the screw [1] at the parking brake valve block and unscrew it until you feel resistance (approx. 5 turns).
- ▶ Release the spring-operated brakes by turning the steering wheel to the left until increased turning power is required.
- ✓ Pretension force of the spring-operated brake is reduced.
- ✓ The parking brake is non-functional.
- ✓ The machine can be towed.
- ▶ During towing, the spring-operated brakes must be kept open by repeated releasing with the steering wheel due to interior leaks.

Enable the spring-operated brake again

- ▶ Screw in screw [1] down to the valve seat at the parking brake valve block (max. 30 Nm).
- ✓ Parking brake is applied again.
- ✓ The machine can be repaired.

3.25.04 After towing/before repair

Parking machine safely at the location to which it has been towed

- ▶ Prevent the machine from rolling away with suitable protective measures (e.g. chocks).
- ▶ Enable the parking brake again (see "Release spring-operated brake").
- ▶ Reconnect the hydrostatic transmission (see "Depressurize the hydraulic system").
- ▶ Remove towing tool.
- ✓ Machine safely shut down.
- ✓ The prerequisites for repair are fulfilled.



After the repair: The machine must not be brought back into use until a complete function test has been made.

3.26 Start with jump leads

Preparation for start assistance

- Observe precaution measures for handling batteries (see Safety instructions).
- A discharged battery can freeze already at 0 °C (32 °F). Thaw a frozen battery in a warm room. Remove the plug.
- Do not disconnect the battery from the vehicle's internal power supply.

Connecting jump leads

▲ WARNING

Explosion and electric shock!

Severe injury and death due to moving parts, burns or electric shock.

- Charging vehicle and discharged vehicle may not come in contact with each other.
- The pole terminals of the jump leads must not be allowed to touch each other.
- Move the pole terminal on the vehicle ground of the unloaded vehicle as far as possible away from the negative pole of the discharged vehicle.
- Pay attention to the nominal voltage of the batteries.
- Use jump leads with an insulated terminal clamp and a cross section of at least 25 mm².

▲ WARNING

Exposed, rotating parts!

Risk of being trapped, pulled in, and injured by rotating engine parts.

- Ensure that no parts of the body or items of clothing can be drawn into rotating or moving engine parts.
- Do not reach into the engine compartment during the start assistance process.
- Route cables such that they cannot be drawn into rotating engine parts.
- Always lay the leads so that they can be removed safely even when the engine is running.



The positive pole of a battery is marked by a Plus (+) sign. The negative pole of a battery is marked by a Minus (-) sign.



The vehicle ground is, for example, the engine block or the fastening screw of the engine mounting.

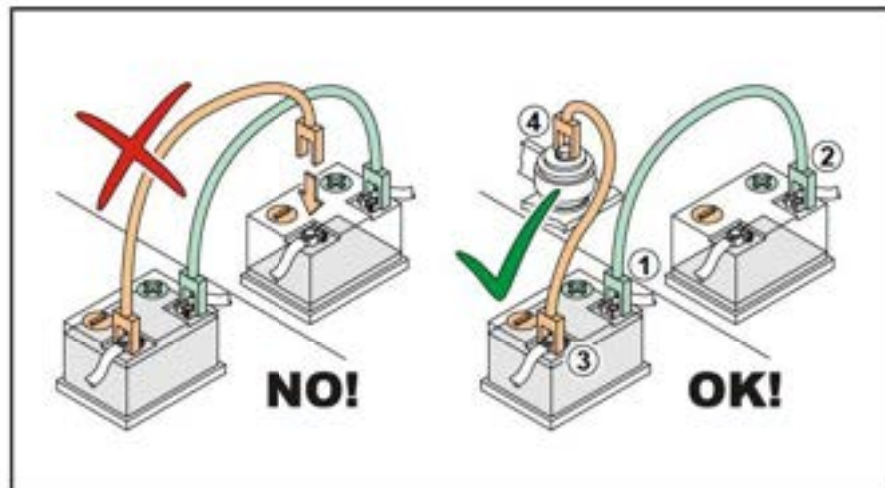

- ▶ Remove the terminal caps from the poles of the batteries.
- ▶ Connect the pole terminal [1] of the first lead to the positive pole of the charged battery.
- ▶ Connect the other terminal clamp [2] of the first lead to the positive terminal of the discharged battery.
- ▶ Connect one terminal clamp [3] of the second lead to the negative terminal of the charged battery.
- ▶ Connect the other terminal clamp [4] of the second lead with the ground of the discharged vehicle.

Starting process

- ▶ Start the engine of the charging vehicle and let it run with medium engine speed.
- ▶ Start the diesel engine of the discharged vehicle after approx. 5 min.
- ▶ For approx. 3 min let both engines run with medium engine speed and the jump leads connected.

Removing jump leads from the batteries

- ▶ Switch on an electric consumer on the discharged vehicle (e.g. driving light) in order to avoid overvoltages in the electrical system.
- ▶ Remove the jump leads in reverse order: Disconnect pole terminal [4], then [3], then [2], then [1].
- ▶ Put the terminal caps on the poles of the batteries.

3.27 Shutting down

3.27.01 Temporarily shutting down the machine and starting it up again

▲ WARNING

Dangerous operating materials!

Risk to health and the environment caused by operating materials that have not been disposed of properly.

- Dispose of operating materials in accordance with the applicable safety and environmental regulations.
- Wear personal protective equipment when disposing of the materials.

If the machine will not be used for an extended period of time, it must be decommissioned and stored correctly.

After storage, the machine must be prepared for recommissioning before it is used again.



The work to temporarily shut down and to recommission the machine requires expert knowledge and may require special tools and equipment.

This work must only be carried out by trained specialists.



The work steps listed below are **NOT INSTRUCTIONS**.

They are a non-exhaustive list of examples of work that must be carried out in order to temporarily shut down and/or recommission the machine.

For precise information or for carrying out the decommissioning and/or recommissioning process, contact customer service.

Decommissioning – temporarily shutting down

All activities that are carried out for the temporary shutdown must be documented. This is the only way to guarantee that the machine can be properly recommissioned following a temporary shutdown.



Catch all liquids in suitable containers and dispose of them properly in accordance with the relevant specifications and national regulations.

- ▶ Wear personal protective equipment:
 - Protective work wear
 - Safety goggles
 - Protective gloves
 - Safety shoes.
- ▶ Thoroughly clean the inside and outside of the machine.
- ▶ Preserve any sealing elements using acid-free grease.
- ▶ Check the drive unit, auxiliary units, hoses, hose connections and flange-mountings for leaks and/or escaping operating and auxiliary materials. If there are any anomalies, repair any affected components.

- ▶ Remove the batteries and store them in a frost-free environment.
Follow the battery manufacturer's instruction manual.
- ▶ Drain and preserve the fuel system.
- ▶ Fill the AdBlue®/DEF reservoir to 25%.
- ▶ Check the coolant level and, if required, top it up.
- ▶ Drain the engine oil and preserve the engine using running-in preserving oil.
- ▶ Check the gear oil level and, if required, top it up.
- ▶ Drain the liquids from the tanks for water sprinkling, additive sprinkling and the windscreen washer system.

Storage

- ▶ Store the machine and machine components in well-ventilated, lockable, temperature-controlled and dry rooms.
- ▶ When storing outdoors, place the machine and machine components on suitable underlays in order to protect them against moisture and cover them using tarpaulins that open at the bottom. Secure the tarpaulins using suitable lashings.

Recommissioning

- ▶ Check the drive unit, auxiliary units, hoses, hose connections and flange-mountings for leaks and/or escaping operating and auxiliary materials. If there are any anomalies, repair or replace any affected components.
- ▶ Drain and dispose of the preserving liquids.
- ▶ Fill pipe systems with operating and auxiliary materials e.g.: engine coolant, engine oil, gear oil, AdBlue®/DEF, water sprinkling, additive sprinkling.
- ▶ Check and, if required, repair all of the components.

3.27.02 Permanently shutting down and disposing of the machine

▲ WARNING

Dangerous operating materials!

Risk to health and the environment caused by operating materials that have not been disposed of properly.

- Dispose of operating materials in accordance with the applicable safety and environmental regulations.
- Wear personal protective equipment when disposing of the materials.

If the machine is no longer designated or suitable for the intended use, it must be decommissioned in accordance with the applicable regulations.



The work to permanently decommission the machine requires expert knowledge and may require special tools and equipment.

This work must only be carried out by trained specialists.



Disposing of operating materials



The work steps listed below are **NOT INSTRUCTIONS**. They are a non-exhaustive list of examples of work that must be carried out in order to permanently decommission the machine.

For precise information or for carrying out the decommissioning, contact customer service.



Catch all liquids in suitable containers and dispose of them properly in accordance with the relevant specifications and national regulations.

- ▶ Wear personal protective equipment:
 - Protective work wear
 - Safety goggles
 - Protective gloves
 - Safety shoes.
- ▶ Remove the batteries and dispose of them in accordance with the statutory provisions.
Follow the battery manufacturer's instruction manual.
- ▶ Drain the fuel tank.
- ▶ Drain the AdBlue®/DEF reservoir.
- ▶ Drain the hydraulic oil tank.
- ▶ Drain the engine coolant circuit.
- ▶ Drain the engine oil circuit.
- ▶ Evacuate the air-conditioning system.
- ▶ Drain the gear oil.
- ▶ Drain the tanks for water sprinkling, additive sprinkling and the windscreen washer system.

Disposing of the machine

- ▶ Hand over any electrical/electronic components to a specialised recycling company.
- ▶ Hand over the machine to an approved recycling company so that it can be destroyed and disposed of.
- ▶ Observe any national and, if required, regional disposal regulations.

4 MAINTENANCE



When working at the machine please always adhere to the instructions given in your Safety instructions!

4.00 General maintenance instructions

This section describes the work on the machine required for its care and to maintain operational safety.

The extent and the frequency of the maintenance work depends on the operating and deployment conditions, which may differ in many cases. In case of more difficult operating conditions, the machine must have maintenance in shorter intervals as scheduled for normal operation.

The maintenance intervals are based on the operating time indicated by operating hours meter.

Various warning and pilot lights make the driver aware of essential interventions during operation.

Additional maintenance work must be carried out in the running-in time. They are described in the running-in regulations.

The running-in regulations, servicing intervals and care measures for diesel engine must be adhered as specified in the instruction manual of the diesel engine manufacturer.

4.00.01 Important information about maintenance works

Testing and maintenance work require expert knowledge. Only trained, specialist personnel may perform the maintenance work.

The warning notices indicated below apply to all maintenance work:

▲ WARNING

Unintended machine movement!

Severe injury or death due to unexpected machine movements during maintenance work.

- Park the machine on safe ground, i.e., flat and horizontal ground with sufficient bearing capacity.
- Secure machine against rolling away.
- Do not carry out any maintenance work unless the engine has been stopped and the ignition has been switched off.
- On machines with safety strut, apply the safety strut before maintenance work.



▲ WARNING

Unintended engine start!

Severe injury and death caused in case of an unintended engine start during maintenance work.

- Do not carry out any maintenance work unless the engine has been stopped and the ignition has been switched off.
- Before starting maintenance work, set the battery isolating switch to off in order to de-energize the electrical system. As an alternative, disconnect the earthing/grounding strip from the battery.
- To avoid any unintended engine start by any third person, affix a warning notice at the driver's position indicating that work is in progress on the machine.

▲ WARNING

Exposed, rotating parts!

Risk of being trapped, pulled in, and injured by rotating engine parts.

- Do not perform any testing, adjusting or maintenance work in the area of the engine unless the diesel engine has been switched off.
- Do not reach with your hands into the area of the engine unless after every part has come to a standstill.
- Do not lay down any object or tool in the engine compartment.
- Keep a safety distance when making a visual inspection while the diesel engine is running.

▲ WARNING

Hot surfaces, hot fluids!

Injury by burns on hot surfaces or by hot fluids.

- Before starting any work on the diesel engine, the cooling system, the exhaust system, or the hydraulic system: Allow machine to cool down less than 30 °C (86 °F).
- Do not touch hot machine parts.
- Do not check the filling level, do not drain or top up any fluid unless the machine has cooled down.

▲ WARNING

Fluids under pressure!

Serious injury can be caused by liquids escaping under high pressure.

- Do not perform any maintenance work on the hydraulic system, the cooling system, the fuel system, or the air conditioning system unless the lines have turned off.
- Lower raised devices to the ground.
- After switching off the diesel engine, wait at least 1 minute until the pressure has been reduced.
- Wear personal protective equipment.

▲ WARNING

Work above floor level!

Injury caused by falling.

- Do not perform any maintenance or repair work above ground level unless using a stable ladder or a maintenance scaffold.
- To reach the maintenance points on the machine, use the steps indicated. Do not step on any other machine element or add-on part.

▲ WARNING

Noxious exhaust gases!

Risk of serious injury or death caused by poisoning or suffocation after breathing in exhaust gases when operating the machine in an enclosed space.

- Only operate the machine outdoors.
- If the engine has to run in enclosed spaces:
 - Guide the exhaust gases outside (extension hose).
 - Ensure that there is a sufficient supply of fresh air, e.g. by using a ventilation system or by opening the doors.

▲ CAUTION

Electrical voltage!

Risk of injury due to electric shock.

- Before starting maintenance work, set the battery isolating switch to off in order to de-energize the electrical system. As an alternative, disconnect the earthing/grounding strip from the battery.
- Wear personal protective equipment.
- When working on the electrical system, be sure to only use suitable and approved tools.

NOTICE**Short-circuits on electrical components!**

Destruction or damage of machine parts by a short-circuit.

- Before starting maintenance work, set the battery isolating switch to off in order to de-energize the electrical system. As an alternative, disconnect the earthing/grounding strip from the battery.
- Observe the operating instructions when using a jumper cable.
- Do not lay any tool or machine element on the battery.

NOTICE**Engine hood swinging range!**

Material damage when opening the engine hood.

- Keep a sufficient distance to other objects located either above or at the rear.

NOTICE**Uncontrolled movements!**

Damage to machine or environment by uncontrolled steering system movements and by consequent front or rear end swings.

- Applying safety strut before:
 - crane loading the machine.
 - transporting the machine.
 - maintenance and repair work.

**Note on the environment:**

Catch and properly dispose of any liquid escaping or drained during any maintenance work.

4.00.02 Running-in instructions



For engine maintenance, see instruction manual for diesel engine.

After 50 operating hours

Servicing diesel engine

- ▶ Change the engine oil ([see page 132](#)).
- ▶ Replace the lubricating oil filter ([see page 132](#)).
- ▶ Replace the fuel filter ([see page 132](#)).
- ▶ Replacing the preliminary fuel filter ([see page 133](#)).

Servicing hydraulic system

- ▶ Replace the filter insert of the pressure filter for the hydraulic system ([see page 143](#)).



Axle maintenance

- ▶ Check that wheel nuts/wheel bolt connections are tight ([see page 150](#)).











4.00.03 Maintenance overview



For engine maintenance, see instruction manual for diesel engine.







Every 10 operating hours



-  Check function of the parking brake see page 127
-  Checking that the seat contact switch is working properly see page 127
-  Check the EMERGENCY STOP function when the engine is at a standstill see page 128
-  Check hydraulic oil fill level see page 141
-  Clean the spray nozzles see page 158
-  Check air pressure in the tyres see page 150
-  Check engine oil fill level See the operating manual for the diesel engine
-  Check coolant fill level see page 138
-  Check and clean air filter/dust valve see page 135
see page 135
-  Clean filter for water sprinkling see page 158
-  Drain water separator see page 134

Every 250 operating hours







-  Check/lubricate scrapers see page 147
-  Change engine oil See instruction manual of diesel engine
-  Change lubrication oil filter of diesel engine See instruction manual of diesel engine
-  Check V-belt tension See instruction manual of diesel engine
-  Lubricate pivoted bearing see page 154
-  Lubricate steering cylinder bolts see page 154
-  Check the radiator see page 137

Every 500 operating hours, at least once a year





	Replacing the filter insert in the pressure filter for the hydraulic system	see page 143
	Checking the damping elements	see page 162
	Checking the wheel nuts/wheel bolts for tightness	see page 150
	Replacing the valve cover seal	See the operating manual for the diesel engine
	Replacing the filter cartridge on the fuel filter	see page 132
	Replacing the fuel prefilter	see page 133
	Replacing the air filter cartridge	see page 136
	Checking that the drive lever is working properly	see page 130
	Checking the starter battery	see page 145
		
	Checking the EMERGENCY STOP function when driving	see page 128
		
	Cleaning the water-sprinkling system	see page 158
	Changing the hydraulic oil	see page 142
	Replacing the V-belt	See the operating manual for the diesel engine
	Changing the coolant	see page 139
	Replacing the safety cartridge	see page 136
	Replacing the hydraulic oil tank's ventilation filter	see page 142

Every 1000 operating hours, at least once a year

Every 2000 operating hours, at least every two years



4.00.04 Required maintenance parts



The specifications for the filling capacities of liquids and operating materials refer to the standard version of machine. However, they may deviate, e.g. for hydraulic oil and where attachments and auxiliary devices are installed.

Always observe the operating manual when filling. Fill liquids and operating materials up to the respective mark.

HD 10, HD 12 all types (D1703-M-DI-E4B)

H2303360 →

Quantity	Maintenance part			First time after	Maintenance intervals in operating hours			
					Every 250	Every 500 or 1 x per year	Every 1000 or 1 x per year	Every 2000 or every 2 years
7.0 l	Engine oil	<input type="checkbox"/>		50 D	D			
26.0 l	Hydraulic oil	<input type="checkbox"/>						D
8.0 l	Coolant	<input type="checkbox"/>						D
1	V-belt	Alternator	2471268		A			D
1	Air filter cartridge		2127067		A	D		
1	Safety cartridge		2127069					D
1	Filter cartridge	Lubricating oil	251496	50 D	D			
1	Filter cartridge	Fuel filter	2164645	50 D		D		
1	Fuel prefilter		2091354	50 D		D		
1	Filter insert	Hydraulic system	2322784	50 D		D		
1	Ventilation filter	Oil tank	2247029					D
1	* Ventilation filter	Oil tank	2206829					D
1	Filter insert	Water filter	2033909		A			
1	Seal	Valve cover	2158245			D		
10	Damping elements for the drum suspension		2029281			A		
1	Service kit – All required maintenance parts for the corresponding maintenance intervals			2349670	2349675	2349677		2349678

A = check! Clean/replace/refill if required. D = replace!

Maintenance parts marked as options (*) are not included in the service kit.

4.00.05 Welding work on the machine



Welding work on the machine must only be carried out by specially trained and authorised personnel.

Welding work on the machine may change the properties of the machine and is only permitted with the agreement of the manufacturer.

Welding work on safety-relevant components must only be carried out by the manufacturer's authorised customer service.

▲ WARNING

Fire and explosion!

Serious injuries or death as a result of ignition or explosion of combustible materials (fuels, oil, gases).

- Make sure that there are no flammable or explosive materials in the vicinity of the welding work.
- Put down welding covers.
- Wear personal protective equipment.

▲ WARNING

Toxic fumes and dust!

Risk of serious injury or death caused by poisoning or suffocation after breathing in toxic fumes or particles when welding.

- Wear personal protective equipment (protective mask).
- Remove any paint within at least a 100 mm radius of the areas that are affected by the heat from welding.
- Avoid breathing in dust when sanding paint.
- Do not use solvents or paint strippers to remove paint in enclosed spaces if there is not sufficient supply of fresh air.
- Do not breathe in the fumes from solvents or paint strippers.
- Before welding:
 - Remove any solvent and paint stripper residues using water and soap.
 - Allow the fumes from solvents or paint strippers to evaporate for at least 15 minutes.
 - Remove any containers for solvents and paint strippers (or any other flammable liquids) from the operating area.



NOTICE

Overvoltage and heat!

Material damage to electric/electronic components of the machine caused by electric current or the effects of heat.

- Before starting electrical welding work, remove all connection plugs from electronic components of the machine.
- Connect negative terminal of the welding appliance at the component to be welded in the vicinity of the weld.
- Remove insulating layers of paint before starting welding work.
- Keep welding leads away from the electrical leads of the machine. If not possible, the welding leads cross the machine leads.
- Touch only the welds with live electrodes.
- Prior to welding work remove components which may get damaged by heat or welding work.
- Observe the instruction manual of the diesel engine.

Procedure

- ▶ Switch off diesel engine and remove ignition key.
- ▶ Wait for the 2 minutes after-running time of the machine to pass.
- ▶ Disconnect battery, first negative then positive terminal.
- ▶ Remove plug of the control devices of the machine.
- ▶ Connect negative terminal of the welding appliance in the vicinity of the weld.
- ▶ Do not get too close to other components when welding.
- ▶ Reconnect all connection plugs after welding.
- ▶ Attach battery.

4.01 Chassis/safety devices

▲ WARNING

Uncontrolled driving behaviour!

Severe injury or death due to separate machine movements.

- Ensure that there are no persons or objects in the danger zone of the machine (moved).
- Do not check functioning of safety devices in case there is not enough space.



The machine must not be used if the safety devices do not work.

Call the customer service!

4.01.01 Basic maintenance work

- Check operating and safety instructions on the machine: Replace damaged and/or non-readable signs.
- Ensure that hinges and links move easily and lubricate lightly.
- Check the function of the warning systems (e.g. signal horn, reflectors, back-up alarm, blinker and warning flasher). Repair/change defective alarm devices/defective parts of the alarm devices.
- Check the function of the lighting. Replace defective lamps.
- Check the firm fit of the screw connections which are subjected to high loads, e.g. articulated joint, tie rod, drum suspension, wheel suspension, drum drive, wheel drive.
- Check that the air filter system is undamaged (e.g. no cracks in hoses or enclosures). Replace defective parts.

4.01.02 Checking and replacing steps/slip-resistant surface

Regularly check the non-slip property of the surfaces of the steps and in the driver's cab (e.g. sand-coated foil).

For steps:

- ▶ Replace or regrind non-slip profiles with a minimum height of 1 mm.

For sand-coated foils:

- ▶ Replace ineffective or worn foils.

4.01.03 Checking that the parking brake is working properly

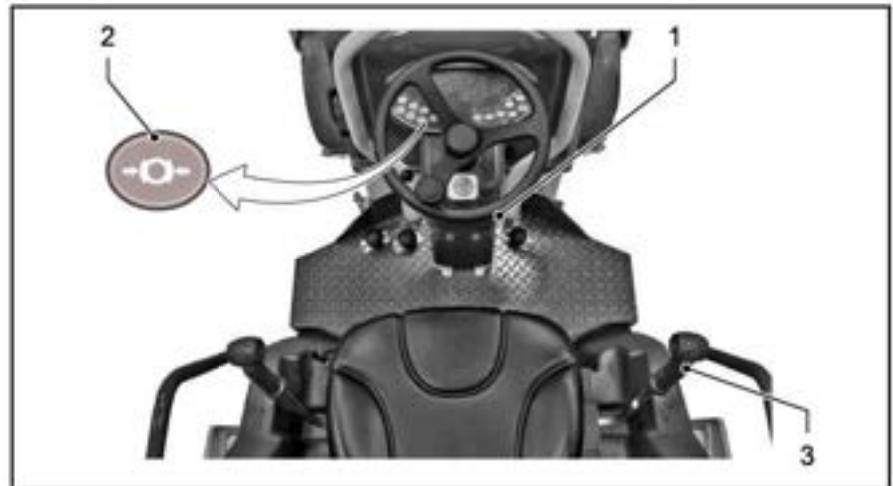

Checking the parking brake when the machine is stationary

Prerequisite: The drive lever is locked in position 0.

- ▶ Start the diesel engine [1].
- ▶ To apply the parking brake: Press the parking brake switch [2].
- ▶ Briefly push the drive lever [3] forwards.
- ✓ The parking brake is working properly if the travel drive is disabled when the parking brake is applied.
- ▶ After the check: Return the drive lever [3] to position 0 and release the parking brake [2].
- ✓ The machine is ready to start.



If the parking brake is worn to such an extent that driving off is possible even when the switch [2] is pressed, the parking brake must be inspected or replaced. The machine must not be operated until this work has been carried out. Request assistance from customer service!

4.01.04 Checking that the seat contact switch is working properly

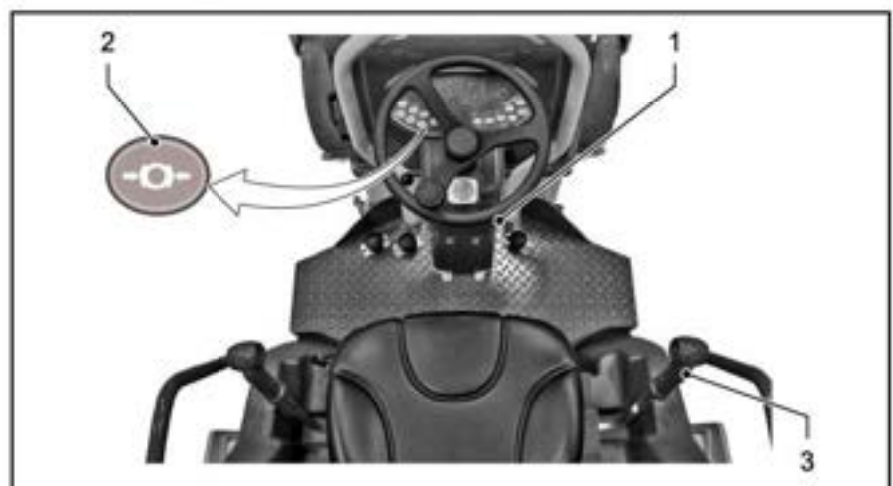

Checking the seat contact switch when the machine is stationary

- ▶ Start the diesel engine [1].
- ▶ Stand up from the driver's seat (looking forwards). Be sure of your footing and hold on tight.
- ▶ To release the parking brake: Press the parking brake switch [2].
- ▶ Briefly push the driving lever [3] forwards.
- ✓ The machine does not start moving: The seat contact switch is working properly.
- ✓ The machine starts moving: The seat contact switch is not working properly.
- ▶ After the check: Return the driving lever [3] to the 0 position and apply the parking brake [2].



If the seat contact switch does not work, it must be tested and repaired without delay. The machine must not be operated until this has been completed. Contact customer service!

4.01.05 Checking the EMERGENCY STOP function

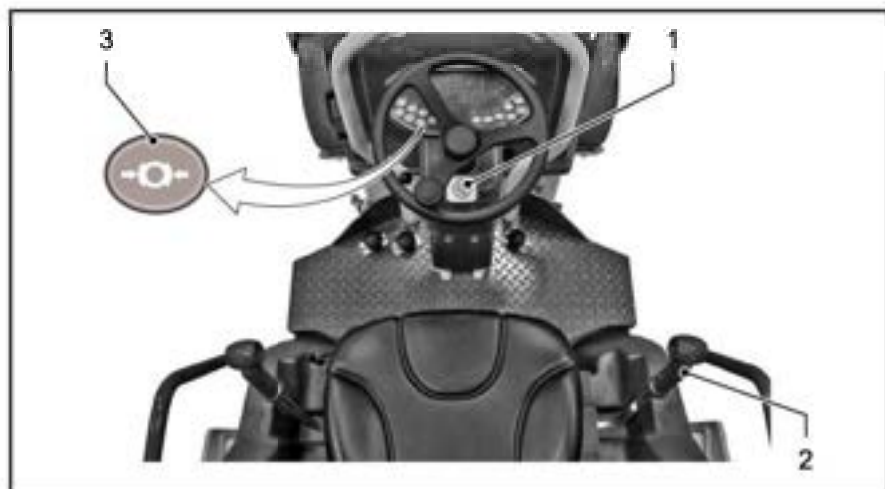

Checking function with machine at standstill (daily)

- ▶ Engage drive lever [2] in the 0-position.
- ▶ Start the diesel engine.
- ▶ Press the parking brake [3] switch.
- ▶ Press EMERGENCY STOP [1] when engine at standstill.

The machine:

- ✓ switches off the working functions.
- ✓ Shuts down the diesel engine.



Checking function during machine operation (annually)

Perform the functional test while the diesel engine is running.

- ▶ Press EMERGENCY STOP [1] with low speed 0.5 km/h (0.3 mph).

The machine:

- ✓ Stops immediately.
- ✓ Shuts down the diesel engine.



If the machine reacts other than as described above or if the EMERGENCY STOP does not work, it must be tested and repaired without delay. The machine must not be used until this has been done. Request assistance from customer services!

4.02 Control stand

4.02.01 Checking the drive lever function

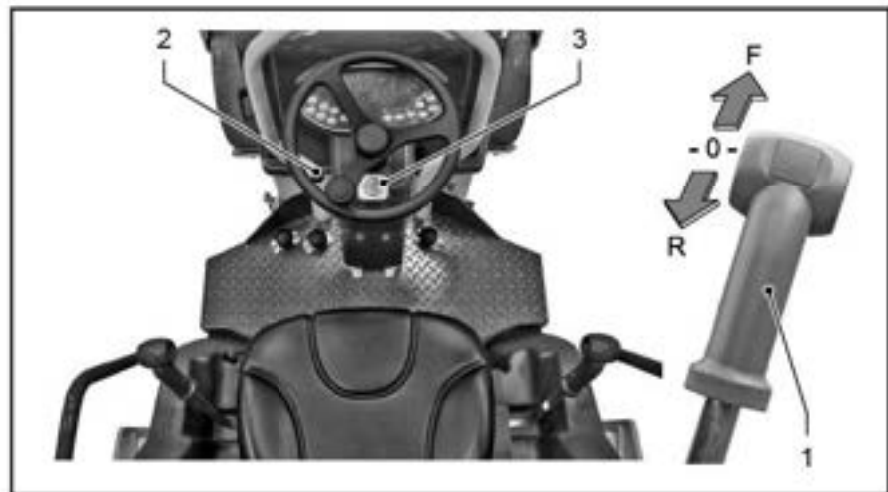

Before making the functional check, set the controls to their home positions:

- Engage drive lever [1] in the 0-position.
- Set the motor speed [2] to MIN.
- Unlock the emergency stop [3].

Functional test

- ▶ Switch off diesel engine and remove ignition key.
- ▶ Move the drive lever [1] fully forward and fully backward.
- ✓ The drive lever must allow even movement in both directions without using excessive force.
- ▶ Lock the drive lever [1] in its 0 position after the functional check.



No machine operation is permitted if the drive lever binds or is sluggish.

Request assistance from customer services!



4.03 Drive unit/diesel engine

▲ WARNING

Inflammable fuel!

Severe injury and death due to fire, explosion and moving parts.

- Do not smoke. No open fire!
- Do not inhale fuel fumes.
- Catch spilling fuel or water sump, do not allow to seep away into the ground!

▲ WARNING

Fuel is under very high pressure!

Serious injury can be caused by liquids escaping under very high pressure.

- Carry out maintenance works only with depressurized fuel system.
- Wait 1 minute after you switched off the diesel engine until the pressure is relieved.
- Work on the high-pressure lines of the fuel injection system may be carried out by trained specialised personnel only.
- Wear personal protective equipment.

NOTICE

Inadmissible fuel or inadmissible lubricating oil for the diesel engine!

Property damage to the diesel engine or to the system for exhaust treatment.

- Only use the fuel specified in the operating instructions.
- Only use the engine oil specified in the operating instructions.
- Observe the indicating labels affixed at the filler necks for fuel and engine oil.

NOTICE

Dirt in the fuel system!

Material damage to the diesel engine as a result of contamination in the fuel system.

- Ensure that no dirt or dust can get into the fuel system (cover dirty areas with foil).
- Thoroughly clean and dry components and the surrounding areas (e.g. with a high-pressure cleaner).

NOTICE

Contaminated inlet air

When it is defective, clogged, or contaminated, the air filter can damage the engine.

- Inspect all lines, flexible tubes and the casing of the air filter for tightness and integrity on a regular basis (at least once per year).
- Immediately replace any damaged part. Further operation is inadmissible.
- Check the operating readiness of the air filter on a regular basis.
- Regularly clean the air filter casing.
- Do not clean but always replace the air filter cartridge and the safety cartridge.
- Never run the diesel engine without an air filter cartridge and a safety cartridge in the air filter.



The fuel system must be bled after all work on an open fuel system or if the fuel tank has been run empty. Check the fuel system for leaks with a trial run!



Adhere to running-in regulations, servicing intervals and care measures for diesel engine as specified in the instruction manual of the engine manufacturer.

4.03.01 Lubricating oil change intervals

These intervals depend, e.g., on:

- Lubricating oil quality
- Fuel sulphur content
- The mode in which the diesel engine is used

Change lubricating oil after half the interval indicated, e.g., when at least one of the following conditions is true:

- Continuous ambient temperature below $-10\text{ }^{\circ}\text{C}$ ($14\text{ }^{\circ}\text{F}$) or lubricating oil temperature below $60\text{ }^{\circ}\text{C}$ ($140\text{ }^{\circ}\text{F}$)
- Operation using biodiesel fuel



Change the lubricating oil at least once per year if the lubricating oil change intervals are not reached before the year ends.

4.03.02 Maintenance points at the diesel engine when changing oil



For engine maintenance see instruction manual for diesel engine!

Only lubricants with this symbol are permitted ("[Technical data](#)", [page 163](#)).

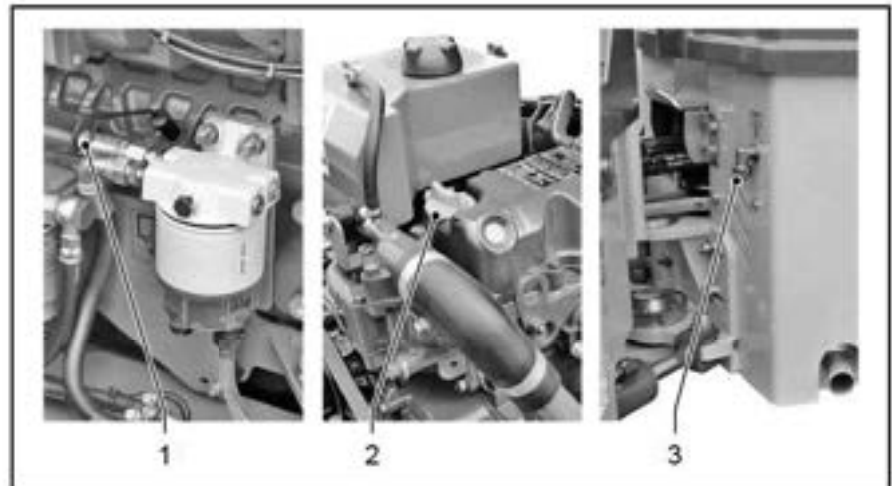

- | | | | |
|-----|-----------------------|-----|--------------------------------|
| [1] | Engine oil dipstick | [2] | Filling opening for engine oil |
| [3] | Engine oil drain plug | | |

4.03.03 Fuel prefilter

Changing filter cartridge for the fuel pre-filter



- ▶ Switch off diesel engine and remove ignition key.
- ▶ Allow machine to cool down under a temperature of 30 °C (86 °F).
- ▶ Open the drain valve [1] (screw conical nipple into housing).
- ▶ Open the vent screw [4].
- ▶ Drain fuel and waste sump from the filter.
- ▶ Unscrew filter cartridge [3].
- ▶ Unscrew the drain housing [2] from the filter cartridge and clean it.
- ▶ Remove contamination from drain valve [1] (check function).
- ▶ Screw the drain housing [2] with a new gasket ring to the filter cartridge [3] and tighten by hand. Close drain valve [1] (unscrew the conical nipple from the housing until the stop).
- ▶ Prior to assembly apply a thin coat of oil to the rubber seal and screw the new filter cartridge [1] to the filter head until the seal

makes contact. Tighten the filter cartridge by hand further by half a turn.

- ▶ Screw in and tighten the vent screw [4].
- ▶ Open the purge screw [5] at the fuel filter cartridge [6] by one turn.
- ▶ Switch on the electrical system until fuel runs out of the vent hole [5] of the fuel filter cartridge.
- ▶ Screw in and tighten the vent screw [5].
- ▶ Check for tightness after assembly.



Air in the fuel system is fully vented when starting the diesel engine. For this, several starting attempts may be necessary. The start process can be activated for a maximum of 20 seconds at a time; otherwise, the starter winding will overheat and be destroyed. There must be pauses of at least 1 minute between the individual starting processes in order to allow the starter to cool down.

Draining the water sump

NOTICE

Water sump in the fuel!

Property damage to the diesel engine by water sump in the fuel system.

- Dewater the fuel prefilter/water trap regularly according to the water content of the fuel.
- If the fuel has a high water content, dewatering must be performed more frequently.



- ▶ Switch off diesel engine and remove ignition key.
- ▶ Allow machine to cool down under a temperature of 30 °C (86 °F).
- ▶ Open the vent screw [1].
- ▶ Open drain valve [2].
- ▶ Allow water sump to drain off.
- ▶ Close drain valve [2].
- ▶ Close the venting plug [1].

4.03.04 Check and clean the dust discharge valve at the air filter

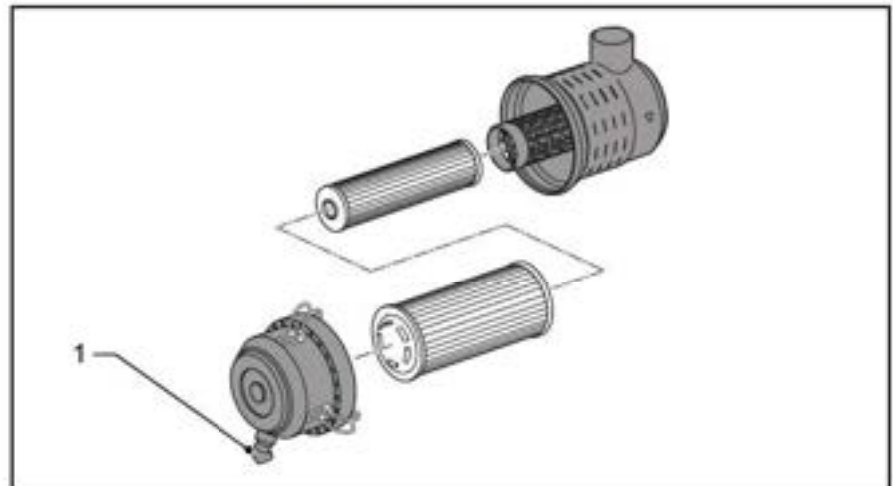

Before starting work, check the proper passage through the dust discharge valve:

- ▶ Switch off diesel engine and remove ignition key.
- ▶ Squeeze the dust discharge valve [1] and clean the discharge slot.

4.03.05 Check the air filter

NOTICE

High pressure by high-pressure cleaner!

Damage of the air filter by power washer.

- Never use compressed air or a high-pressure cleaner for cleaning any casing part.
- Clean the interior parts of the casing only with a moist, fibre-free cloth.

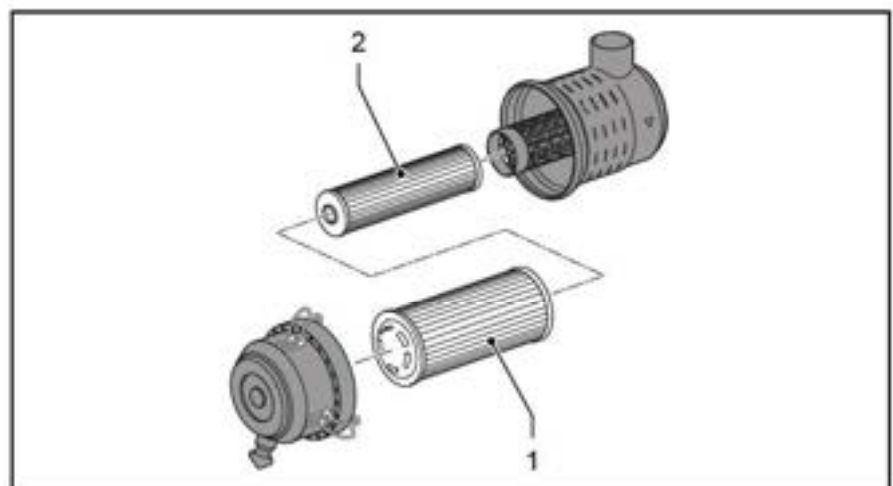

Check the operating readiness of the air filter while the diesel engine is running:

- ▶ Start diesel engine and shortly rev up to maximum speed.
- ✓ The air filter pilot light is not flashing on the information display: Air filter cartridge [1] and the safety cartridge [2] are

ready for operation.

- ✓ Air filter pilot light flashing on the information display: Replace the air filter cartridge [1] and/or the safety cartridge [2].

4.03.06 Replacing air filter cartridge

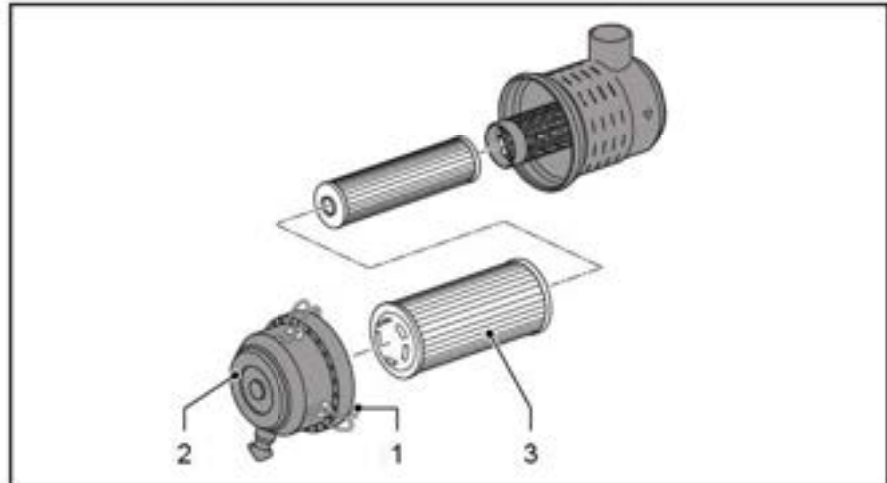

- ▶ Switch off diesel engine and remove ignition key.
- ▶ Allow machine to cool down less than 30 °C (86 °F).
- ▶ Fold up the clips [1].
- ▶ Remove dust collection container [2].
- ▶ Clean the inside of the dust collectors.
- ▶ Pull out the air filter cartridge [3].
- ▶ Insert a new air filter cartridge.
- ▶ Put on the dust receiver bin [2].
- ▶ Snap shut the clips [1].
- ▶ Check the operating readiness of the air filter.

4.03.07 Replacing the safety cartridge at the air filter

Replace the safety cartridge:

- after having changed the air filter cartridge five times.
- After 2000 operating hours at the latest.
- If the air filter pilot light is flashing on the information display after having replaced the air filter cartridge.
- If the air filter cartridge is defective.

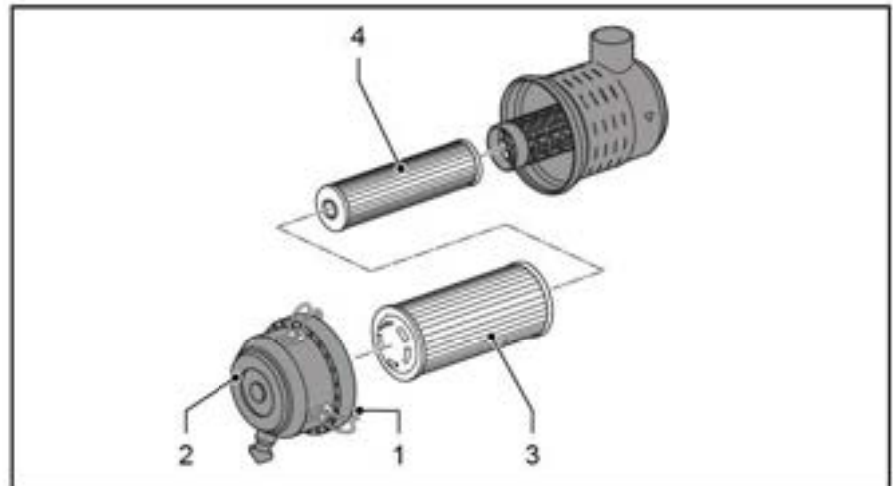

- Changing safety cartridge**
- ▶ Switch off diesel engine and remove ignition key.
 - ▶ Allow machine to cool down less than 30 °C (86 °F).
 - ▶ Fold up the clips [1].
 - ▶ Remove dust container [2].
 - ▶ Clean the inside of the dust container.
 - ▶ Pull the air filter cartridge [3] out of the air filter.
 - ▶ Pull out safety filter cartridge [4].
 - ▶ Slide in a new safety cartridge.
 - ▶ Slide a new air filter cartridge [3] into the air filter.
 - ▶ Put on the dust receiver bin [2].
 - ▶ Snap shut the clips [1].
 - ▶ Check the operating readiness of the air filter.

4.03.08 Checking/cleaning radiator

NOTICE

High water pressure by high-pressure cleaner!

Damage of radiator when cleaning with high-pressure cleaner.

- Maintain a safe distance between the lance of the high-pressure cleaner and the radiator.
- Use a directed spray.
- Guide the directed spray parallel (not at an angle) to the cooling fins of the radiator.



In contrast to the "Improper use" section in chapter 1 (point "Spraying with high-pressure cleaners or fire-extinguishing equipment"), the radiator can be cleaned using a high-pressure cleaner if the person carrying out this task has the appropriate expertise and training.

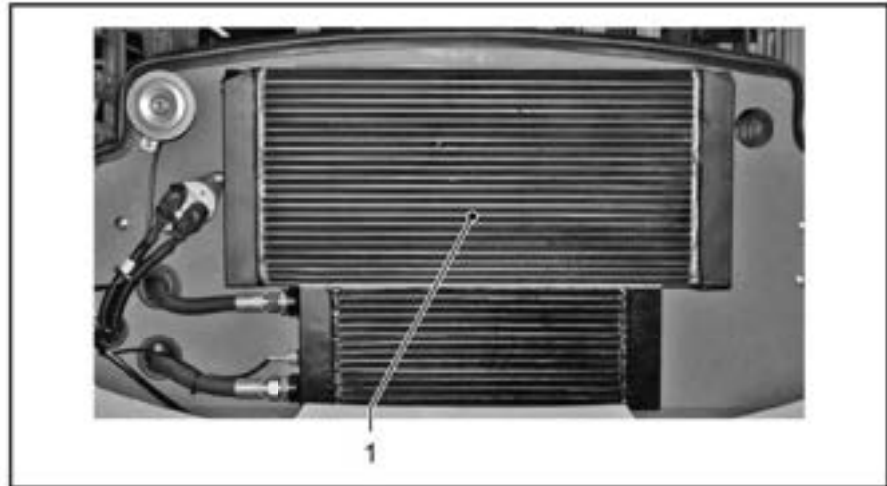

Check the radiator

- ▶ Check the cooling fins of the radiator for fouling.
- ✓ Cooling fins not soiled: The machine is ready for operation.
- ✓ Cooling fins contaminated: Clean the cooling fins thoroughly and without delay.

Cleaning radiator

- ▶ Switch off diesel engine and remove ignition key.
- ▶ Allow machine to cool down less than 30 °C (86 °F).
- ▶ Opening the engine hood.
- ▶ Clean the radiator [1] carefully with a high-pressure cleaner from all sides.
- ▶ Close the engine hood.

4.03.09 Checking coolant fill level

○ Only lubricants with this symbol are permitted ("[Technical data](#)", [page 163](#)).

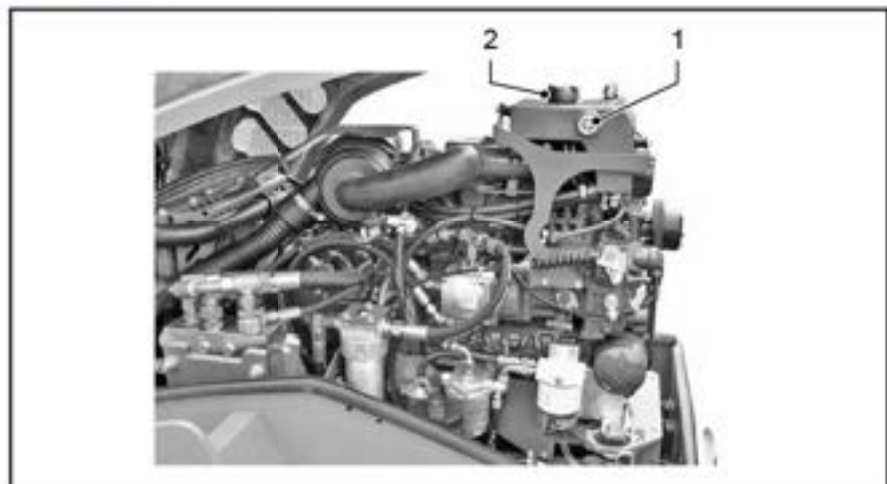

- ▶ Switch off diesel engine and remove ignition key.
- ▶ Only check the coolant level when the diesel engine is cold.

- ▶ Correct coolant level: Centre of inspection glass [2] on compensator tank. Do not exceed this level!
- ▶ If there is insufficient coolant, only fill up coolant in the mixing concentration through filling opening [1] on the compensation tank.
- ▶ In case of bigger coolant losses, find out and eliminate the cause.

4.03.10 Changing coolant

○ Only lubricants with this symbol are permitted ("Technical data", page 163).

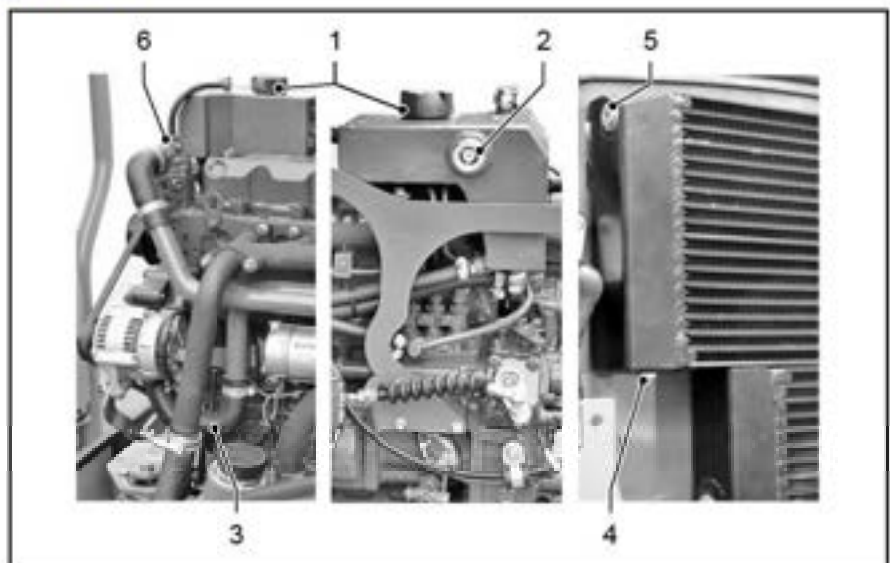

- ▶ Switch off diesel engine and remove ignition key.
- ▶ Open the sealing cap [1] at the compensator tank.
- ▶ Remove the drain plug [4] from the radiator and discharge the coolant in a provided receptacle.
- ▶ Dismount lower coolant hose [3] and discharge coolant into a provided receptacle.
- ▶ Screw in again and tighten drain plug [4] and install coolant hose [3] to the connection piece.
- ▶ Loosen vent screw [5] on the radiator in 2 turns (do not remove!).
- ▶ Open the banjo bolt [6] for the vent line connection on the engine block by two turns (do not remove!).
- ▶ Fill in coolant in the compensator tank [1] until coolant runs out of the vent screw [5].
- ▶ Tighten vent screw [5] at the radiator.
- ▶ Fill in coolant in the compensator tank until it runs out of the hollow-core screw [6] on the engine block.
- ▶ Tighten the hollow screw [6].
- ▶ Fill coolant up to the centre of the inspection glass [2].
- ▶ Close the filling opening with the sealing cap [1].



- ▶ Start the diesel engine and bring it to operating temperature (thermostat opens).
- ▶ Switch off diesel engine and remove ignition key.
- ▶ Check coolant level when the diesel motor is cold, fill up as necessary.
- ▶ Correct coolant level: Centre of inspection glass [2] on compensator tank.

4.04 Hydraulic oil supply

⚠ WARNING

Leaks in hydraulic hoses!

Injuries or fire as a result of oil squirting out of a leaking hydraulic system.

- All lines, hoses and screwed connections of the hydraulic system must be checked for leaks and visible damage (at least once per year).
- Immediately replace any damaged part. Further operation of the machine is inadmissible.

NOTICE

Foreign objects in the hydraulic system!

Consequential damage to the hydraulic system caused by foreign objects in the hydraulic system as a result of earlier damage.

- After a each damage to the hydraulic system, with a foreign object having entered the oil circuit, the entire hydraulic system must be cleaned.
- After cleaning, replace all suction, return and pressure filters in the hydraulic system after 50 hours and again after 125 operating hours.
- This work may only be performed by trained specialised personnel. Call the customer service!

4.04.01 Checking hydraulic oil level

Only lubricants with this symbol are permitted (["Technical data", page 163](#)).



- ▶ Switch off diesel engine and remove ignition key.
- ▶ Allow machine to cool down less than 30 °C (86 °F).
- ▶ Correct oil level: centre of sight glass [2].
- ▶ If the oil level is too low, fill with appropriate oil through the fill opening [1].
- ▶ In case of bigger oil losses, find out and eliminate the cause.

4.04.02 Changing hydraulic oil and ventilation filter

Only lubricants with this symbol are permitted ("Technical data", page 163).

Variant 1 Standard design

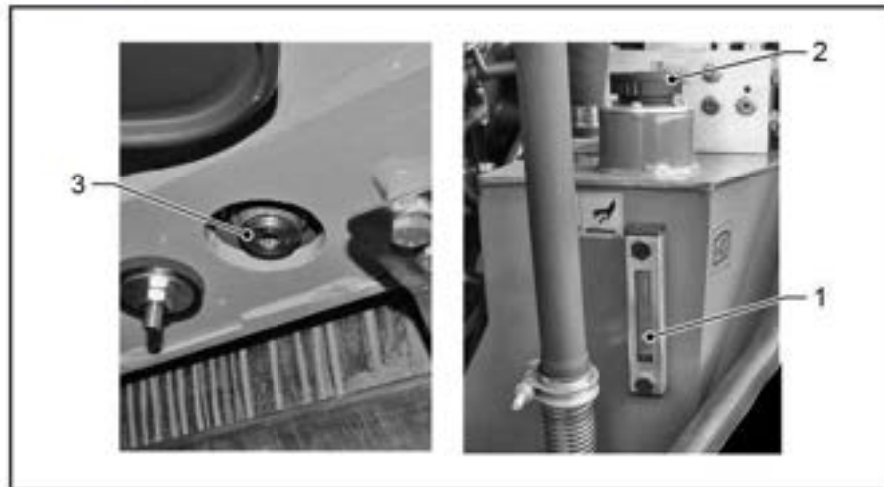

Variant 2 Vandalism proof version

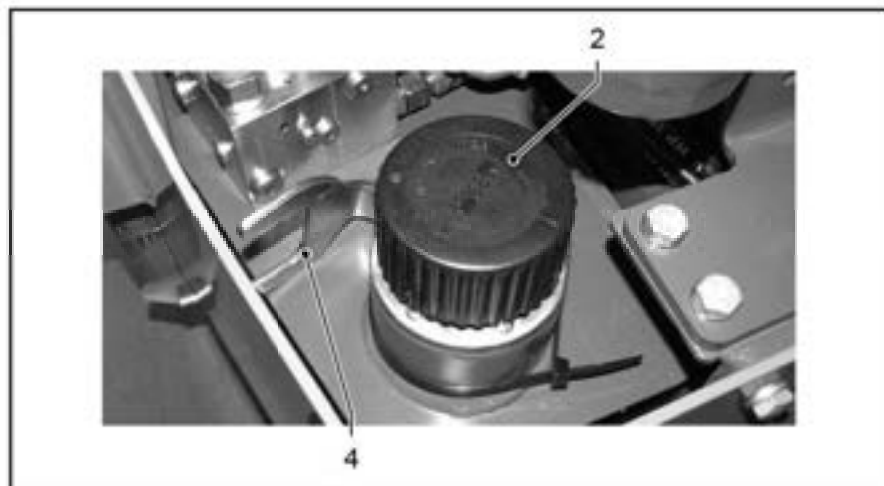

- ▶ Switch off diesel engine and remove ignition key.
- ▶ Allow machine to cool down less than 30 °C (86 °F).
- ▶ Unscrew oil drain screw [3] down on the oil tank and discharge the used oil drain into a provided receptacle.
- ▶ Remove the ventilation filter [2] (for variant 2, use a special key [4] to loosen it before) and replace it with a new filter.
- ▶ Screw in oil drain screw [3] and tighten.
- ▶ Add the specified oil through the filling opening [2].
- ▶ Correct oil level: Centre of sight glass [1].
- ▶ Tighten ventilation filter [2].
- ▶ Start the diesel engine.
- ▶ Actuate drive lever with low engine speed until the transmission activates.
- ▶ Also actuate the steering.
- ✓ The pipes and hose lines will be filled with oil and vented.



- ▶ Check oil level with the diesel engine at a standstill. Top up oil if necessary.
- ▶ Check hydraulic system for leaks.

4.04.03 Replacing filter insert of pressure filter for hydraulic system

Only lubricants with this symbol are permitted (["Technical data", page 163](#)).

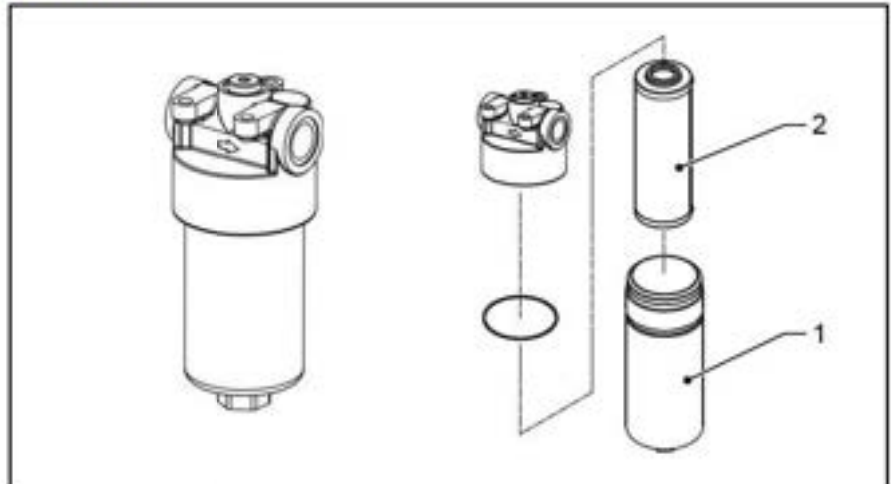

- ▶ Switch off diesel engine and remove ignition key.
- ▶ Allow machine to cool down less than 30 °C (86 °F).
- ▶ Unscrew the barrel casing [1].
- ▶ Unscrew the filter insert [2] from the filter head and replace with a new one.
- ▶ Clean the inside the barrel casing [1].
- ▶ Screw in and tighten the barrel casing [1] in the filter head again.
- ▶ Check hydraulic system for leaks.

4.05 Electrical system

4.05.01 Starter battery

▲ WARNING

Explosion!

Serious injuries or burns caused by exploding gases.

- Naked flames and smoking are prohibited when handling any battery. Be sure to avoid any sparking.
- Do not store or charge the battery unless in a well ventilated room.
- Do not store or charge the battery unless at a temperature of between -15 °C and 45 °C (5 °F and 113 °F).
- Avoid exposure to direct sunlight.
- When charging the battery, be sure to follow the manufacturer's instructions and the operating manual.
- To charge the battery, use direct current only.

▲ WARNING

Toxic and caustic electrolytic liquid!

Serious injuries as a result of poisoning or chemical burning by contact with electrolytic liquid.

- Wear personal protective equipment when working on or handling any battery, i.e., protective clothing, glasses, face mask, acid-proof rubber gloves.
- Do not tip the battery.
- Use suitable means for binding and disposing of any spilled liquid.
- In case of contact with electrolyte fluid, rinse the area affected with clear water, and consult a physician.
- In case of having inhaled or swallowed any electrolyte fluid, initiate emergency medical aid immediately.



Perform maintenance work only in adequately ventilated rooms.

The electrical power supply is ensured by a generator and by a starter battery.

All cables, fastenings and screwed connections must be checked for visible damage (at least once per year).

Damaged parts must be replaced immediately. Damaged cables may cause injuries and fire.

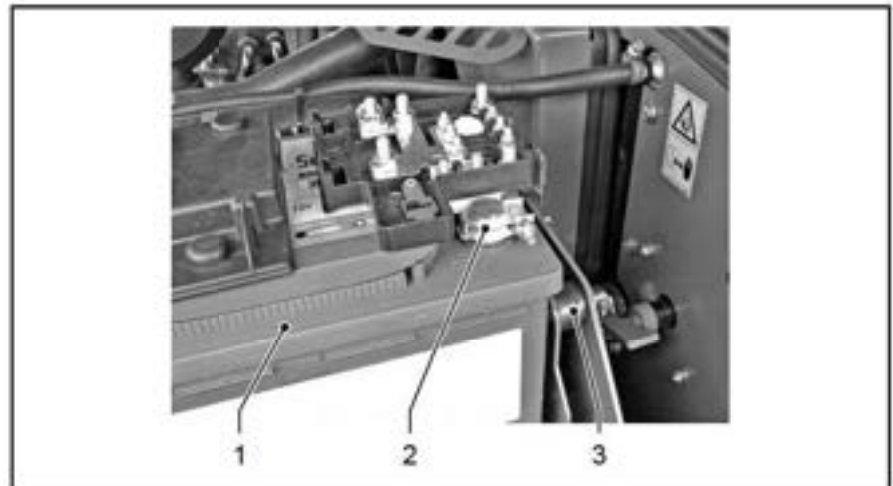

- | | | | |
|-----|--------------------------------|-----|---------------------------------------|
| [1] | Battery case | [2] | Battery terminals and terminal clamps |
| [3] | Battery mounting and fastening | | |

Maintenance

These intervals depend on:

- Storage and ambient temperatures
- Acid level and acid concentration
- Service conditions



Do not open batteries without plugs, or VRLA batteries!
The battery must be replaced if the electrolyte level or the acid concentration falls below the minimum.



Never top up already filled batteries with acid or enhancing agents!
Top up only with distilled water.

- ▶ Switch off diesel engine and remove ignition key.
- ▶ Wear personal protective equipment.
- ▶ If preset: Remove the terminal caps from the battery.
- ▶ Check the battery casing [1] for external damage.
- ▶ Check the battery mounting and storage [3].
- ▶ Clean the battery terminals and terminal clamps [2] and treat with battery terminal grease.
- ▶ Replace the terminal caps on the battery.
- ✓ Battery securely positioned, sealed, undamaged and with its connectors preserved.
- ▶ Check the electrolyte level at the inner or outer casing mark or as indicated in the closing plug (see battery instructions).
- ▶ Top up distilled water or replace the battery as necessary.
- ▶ If possible, check the acid concentration. (1.28 kg/l ±0.1).
- ▶ Clean the battery casing [1] with a damp or antistatic cloth.
- ✓ Correct acid concentration.
- ✓ Correct electrolyte level.

- ▶ Check the battery open-circuit voltage (must be at least 11.9 V) with suitable means, and recharge if necessary.
- ✓ Full starter power.

External charging



Deeply discharged batteries must be removed from the machine for recharging.
Observe the manufacturer's specifications for charger and battery during every charging work step.
Do not charge the battery unless in a well ventilated room.

- ▶ Remove the battery from the machine.
- ▶ Before recharging, ensure that the battery degassing is intact.
- ▶ If possible, check the electrolyte level before charging and correct if necessary (see battery instructions).
- ▶ Connect the battery charger according to the manufacturer's specifications, and then start recharging.
- ▶ Always watch the charging process and stop charging when the acid temperature exceeds 55 °C or in case of acid spill.
- ✓ Battery charged.
- ▶ Switch off and disconnect the charger from the battery.
- ▶ If necessary, remount the battery.
- ✓ Battery is ready for use.

4.06 Transmission

4.06.01 Checking roller drum/tyre scraper

Only scrapers in correct condition ensure a clean roller drum/tyre surface.

- ▶ Check scraper for cleanliness. Clean soiled scrapers.
- ▶ Check the condition of the scrapers. Replace worn scrapers in good time.
- ▶ Check setting of the scrapers. Adjust preset scrapers.

4.06.02 Cleaning roller drum/tyre scraper

- ▶ Rinse out dirt embedded between scrapers and roller drums/tyres with water jet.
- ▶ Remove strongly adhesive dirt with spatula or similar tool.

4.06.03 Replacing/adjusting the roller drum scraper



If they are worn-out to such an extent that sticking dirt is not removed from the roller drums/tyres during work any longer, the scrapers must be readjusted or replaced.

Rigid scraper

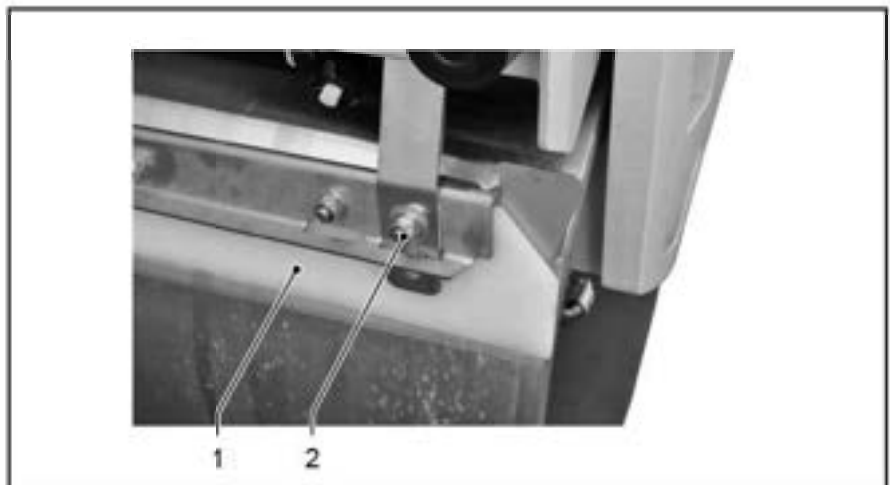

Before carrying out any work on the scrapers:

- ▶ Safely park the machine and secure it against rolling away.
- ▶ Switch off the diesel engine and remove the ignition key.

Readjusting/replacing scrapers

- ▶ Loosen the clamp connection [2].
- ▶ Replace the scraper [1] by a new one if necessary.
- ▶ Push scraper [1] to the roller drum.
- ▶ Tighten clamp connection [2].

Folding scraper

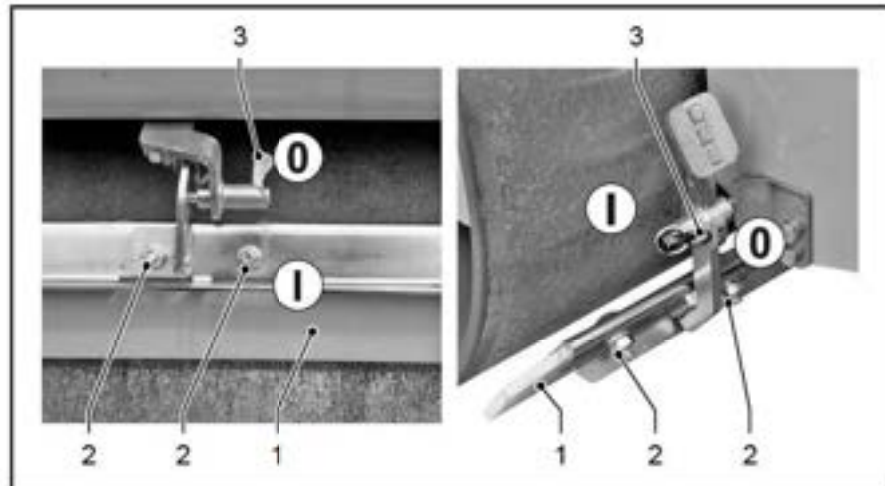

Before carrying out any work on the scrapers:

- ▶ Safely park the machine and secure it against rolling away.
- ▶ Switch off the diesel engine and remove the ignition key.

Changing the scraper

- ▶ Turn the locking lever [3] to position 0.
- ▶ Move the scraper [1] away.
- ▶ Loosen the clamp connection [2].
- ▶ Replace the scraper [1] with a new one.
- ▶ Tighten the clamp connection [2].

4.06.04 Replacing/adjusting type scrapers



If they are worn-out to such an extent that sticking dirt is not removed from the roller drums/tyres during work any longer, the scrapers must be readjusted or replaced.



Fit the new scrapers such that the screws in the clamp connection are located in the lowermost position of the elongated holes.

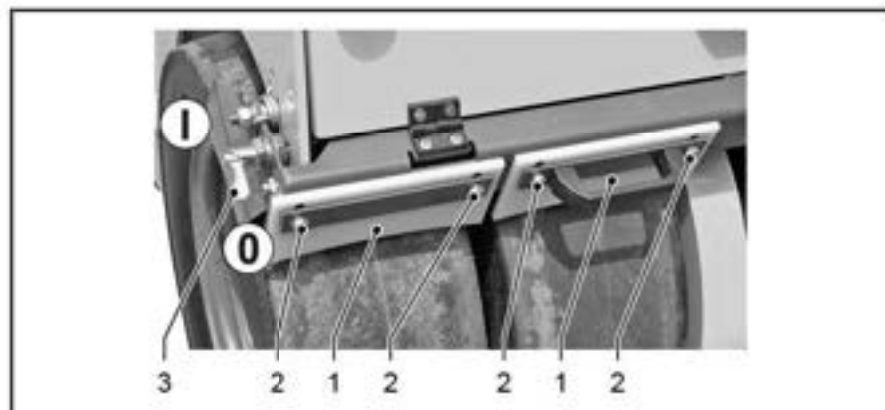

Before carrying out any work on the scrapers:

- ▶ Safely park the machine and secure it against rolling away.
- ▶ Switch off the diesel engine and remove the ignition key.

Adjusting/changing the scraper

Tyre clearance - **10 mm**

- ▶ Turn the locking lever [3] to position 0.
- ▶ Move the scraper [1] away.
- ▶ Loosen clamp connection [2] (2 ×).
- ▶ Replace the scraper [1] with a new one if necessary.
- ▶ Push the scraper [1] towards the tyre until the clearance is reached.
- ▶ Tighten the clamp connection [2].
- ✓ The scraper is adjusted.

4.06.05 Lubricate the scraper stop lever

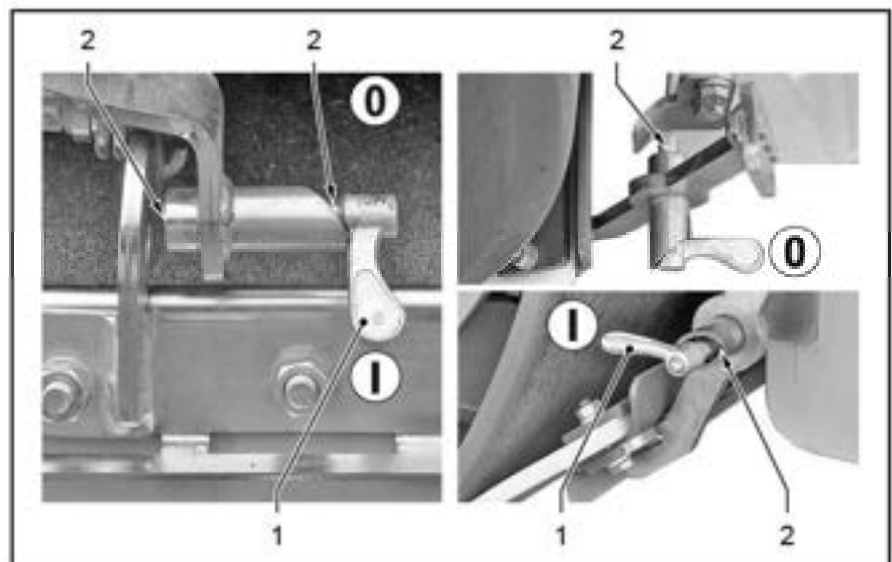

- ▶ Switch off diesel engine and remove ignition key.
- ▶ Clean off dirt adhering to the catch.
- ▶ Turn stop lever [1] to I position.
- ▶ Lubricate the guide bolt of the locking lever with oil at positions [2].
- ▶ Move the locking lever to and fro several times between positions 0 and I to distribute the lubricant in the guide.

4.06.06 Check that wheel nuts/wheel bolt connections are tight

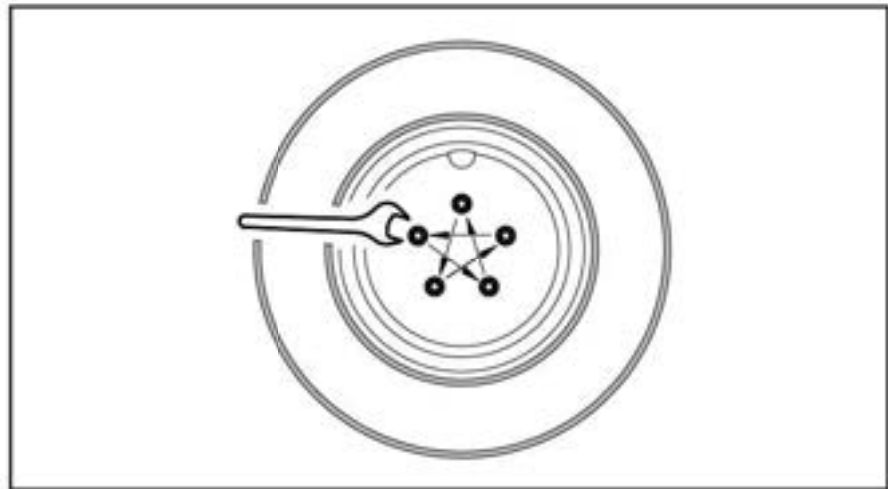

- ▶ Switch off diesel engine and remove ignition key.
- ▶ Tighten the wheel nuts/wheel bolts crosswise. For the tightening torque, see the technical data ([see page 177](#)).

4.06.07 Checking air pressure in the tyres

▲WARNING

Explosion!

Severe injury and death due to explosion and moving parts.

- Change damaged tyres.
- When filling, do not exceed the values of the specified air pressure.
- Use only suitable filling devices with a pressure indicator.
- When filling the tyres, be always next to the tyre, not in front of it.
- Use a tyre cage.

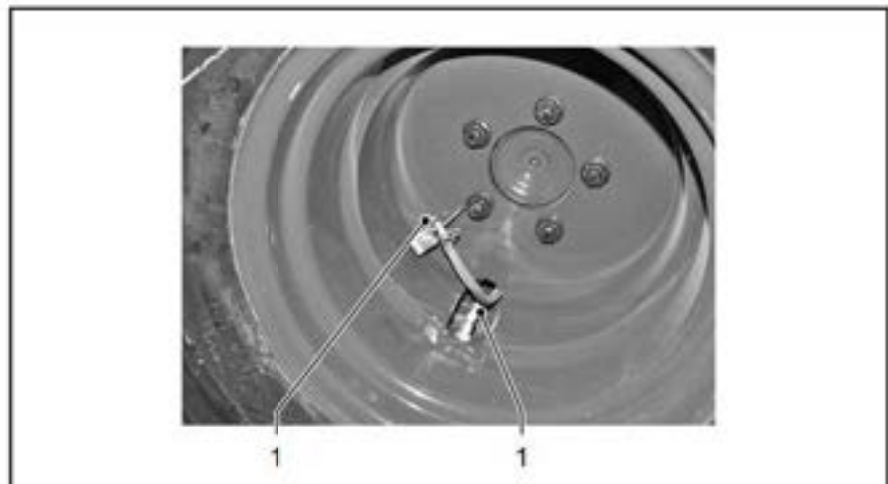

- ▶ Visually inspect the tyre pressure daily.
- ✓ There is no visible air shortage: The machine is ready for operation.

- ✓ Visible air shortage: Obtain the specified air pressure with appropriate filling devices.
- ▶ Switch off diesel engine and remove ignition key.
- ▶ Secure the filling hose to the valve [1] and fill the tyres with the specified air pressure (["Technical data", page 177](#)).

4.06.08 Changing the tyres

▲ WARNING

Tipping over the machine!

Serious injuries or death through the machine tipping over sideways because of a shift in the center of gravity.

- On one axle, only mount and use tyres that are the same type and have the same design, profile and diameter.
- Always set the tyre pressure the same for the tyres of the same axle.

NOTICE

Increased material wear!

Material damage through increased wear on tyres, running gear and drive parts as a result of a combination of different tyres on each axle.

- On one axle, only mount and use tyres that are the same type and have the same design, profile and diameter.
- Always set the tyre pressure the same for the tyres of the same axle.

Preparation



When using a jack, do not place metal on metal.

- ▶ Put machine on a safe surface (even, capable of bearing, horizontal) and secure against rolling away
- ▶ Switch off diesel engine and remove ignition key.
- ▶ Have hoisting gear ready that is appropriate for the weight of the machine and wheels.
- ▶ Lift the machine until the wheels leave the ground:

- Apply a jack with sufficient lifting capacity to the marked lifting points on the chassis, or
 - Lift the machine only by the marked suspension points using suitable hoisting gear (crane with round sling/chain).
- ▶ Put/jack machine on the machine frame on liners capable of bearing (tyres may not be in contact with the ground).



Only persons familiar with changing tyres and aware of dangers are allowed to change the tyres.
When jacking up the machine, use only stable liners capable of bearing (e.g. support timber of sufficient size).
Perform the work with two fitters!

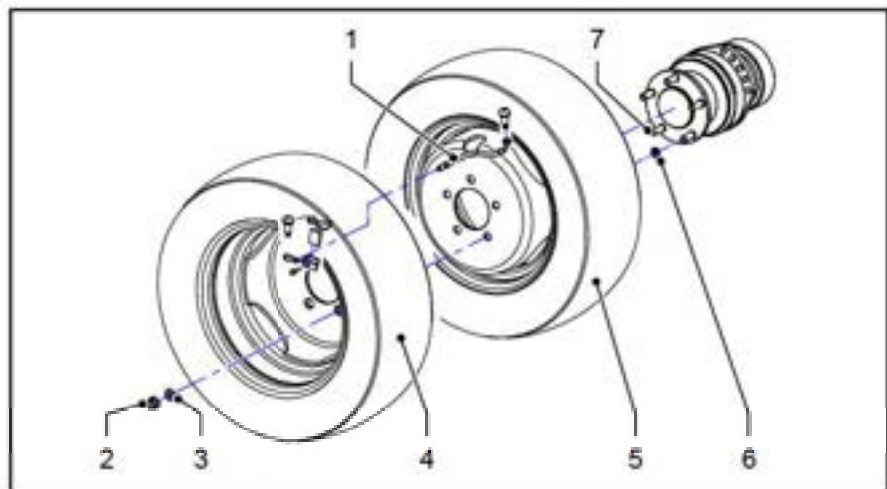

Removal

- ▶ Push the valve extension hose [1] out of the bracket.
- ▶ Undo and unscrew the wheel nuts [2].
- ▶ Remove the retaining rings [3].
- ▶ Remove the wheels [4] and [5] from the wheel hub.
- ▶ Remove the centring rings [6] from the wheel studs [7].

Installation

- ▶ Clean and remove any rust from the contact surfaces between the wheel rims and the wheel hub.
- ▶ Clean and remove any rust from the wheel nuts [2], retaining rings [3] and centring rings [6].
- ▶ Guide the valve extension hose [1] to the outside via the opening on the wheel rims.
- ▶ Place the centring rings [6] onto the wheel studs [7].
- ▶ Place the inner wheel [5] onto the wheel studs [7] on the wheel hub.
- ▶ Place the outer wheel [4] onto the wheel studs [7] in such a way that both valves are aligned.
- ▶ Guide the valve extension hose [1] to the outside via the opening on the wheel rims.
- ▶ Place the retaining rings [3] onto the wheel studs [7].



- ▶ Screw the wheel nuts [2] onto the wheel studs [7] and tighten them to the specified tightening torque.
- ▶ Push the valve extension hose [1] into the bracket.
- ▶ Lift the machine and remove the supports.
- ▶ Set the machine down so that the wheels are in contact with the ground.

4.07 Steering system

▲ WARNING

Uncontrolled movements!

Serious injuries or death caused by unexpected steering movements.

- Perform work on the steering system with the engine at rest and the electrical system switched off.
- On machines with safety strut, apply the safety strut before maintenance work.
- To avoid any unintended engine start by any third person: affix a warning notice at the driver's position indicating that work is in progress on the machine.

4.07.01 Lubricating pivoted bearing

△ Only lubricants with this symbol are permitted ("[Technical data](#)", [page 163](#)).

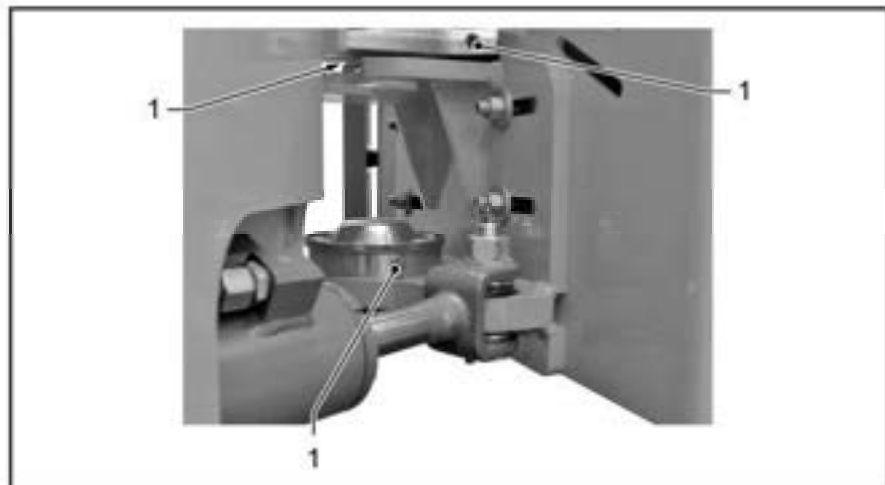

- ▶ Switch off diesel engine and remove ignition key.
- ▶ Apply the articulated frame steering blocking.
- ▶ Grease lubricating nipple [1].

4.07.02 Lubricating the steering cylinder bolts

△ Only lubricants with this symbol are permitted ("[Technical data](#)", [page 163](#)).

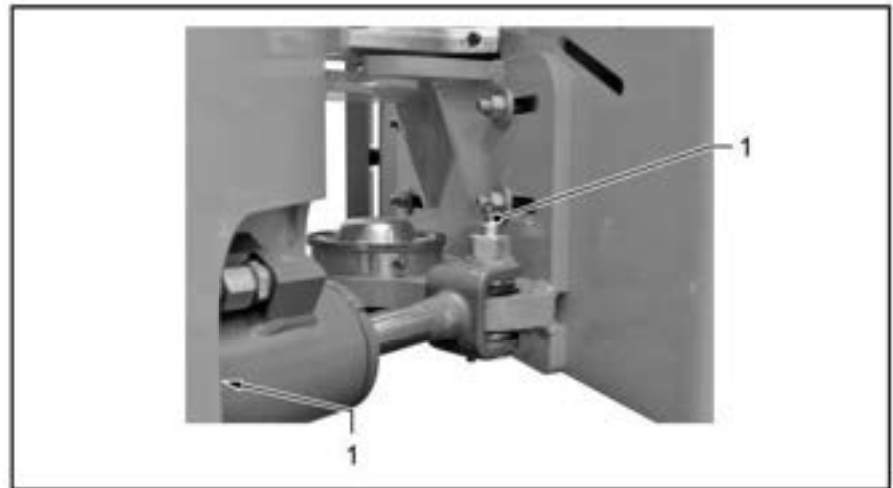

- ▶ Switch off diesel engine and remove ignition key.
- ▶ Apply the articulated frame steering blocking.
- ▶ Grease lubricating nipple [1].

4.08 Water sprinkling

NOTICE

Corrosion and frost!

Material damage to sprinkler installations due to corrosion and frost.

While the machine is going to be parked for an extended period of time and/or in case of danger of freezing:

- Empty and clean the water sprinkling unit/additive sprinkling system.
- Remove and clean the sprinkler nozzles.
- Carry out antifreeze work, if available.

4.08.01 Checking the fill level

The tank for the water sprinkling system is integrated into the control stand.

Add an antifreeze solution when outdoor temperatures are below the freezing point of water. Make sure you use the mixing ratio specified by the manufacturer.

Top up with water in good time.

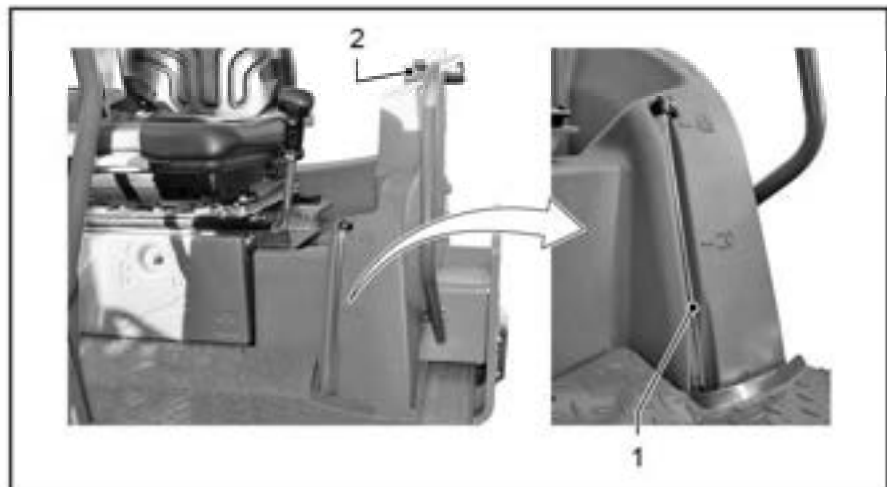

- ▶ Read the fill level of the water tank at the float in the sight glass [1].
- ▶ If it needs to be topped up, open the tank cover [2] and fill the water tank with water.
- ▶ Lock the tank cover [2] again.

4.08.02 Checking the spray nozzles



Check that an even sprinkling pattern is obtained on the roller drums/tyres.

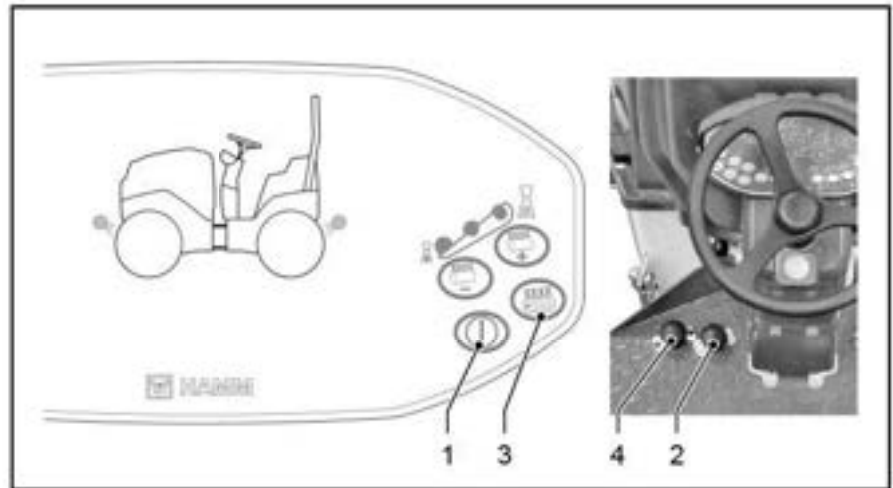

Checking the spray nozzles for the water-sprinkling system

Checking the spray nozzles for the additive-sprinkling system

Prerequisites

- Diesel engine off
- Electrical system on
- Parking brake activated
- For water sprinkling: Drive lever in F position (forward)

- ▶ Press switch [1].
- ✓ Water sprinkling is done by intermittent operation at the preset interval level.
- ▶ Press and hold the foot switch [2].
- ✓ The water sprinkler will be active as long as the foot switch is being pressed.
- ▶ Press the switch [1] again or release the foot pedal [2].
- ✓ Water sprinkling off.
- ▶ Latch driving lever in position 0.
- ▶ Switch off the electrical system.

- ▶ Press and hold the switch [3] or foot switch [4].
- ✓ The additive sprinkler will be active as long as one of the switches is pressed and held.
- ▶ Release switch [3] or [4].
- ✓ Additive sprinkling turned off.
- ▶ Latch driving lever in position 0.
- ▶ Switch off the electrical system.



If the sprinkler does not work or does not produce the desired sprinkling pattern, the sprinkler nozzles need to be cleaned.

4.08.03 Cleaning sprinkler nozzles

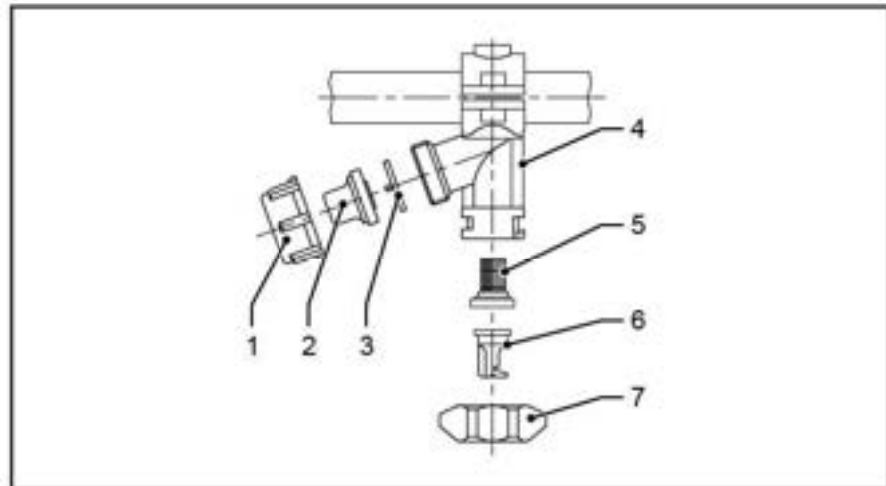

- ▶ Switch off diesel engine and remove ignition key.
- ▶ Loosen the cap nut [7] and remove it together with sprinkler nozzle [6] and filter [5].
- ▶ Remove the filter and the sprinkler nozzle from the cap nut and clean them.
- ▶ Unscrew the cap nut [1].
- ▶ Remove valve insert [2] and membrane [3].
- ▶ Flush the housing [4] with the sprinkling system.
- ▶ Insert the valve core [2] and diaphragm [3] into the union nut [1].
- ▶ Screw the union nut [1] together with the valve core [2] and diaphragm [3] onto the enclosure [4].
- ▶ Insert the filter [5] and spray nozzle [6] into the union nut [7].
- ▶ Screw the union nut [7] together with the spray nozzle [6] and filter [5] onto the enclosure [4].

4.08.04 Cleaning filter for water sprinkling

A large, corrosion-free water filter is arranged upstream of the water pump. It prevents premature contamination of pump, lines and spraying nozzles, thus ensuring trouble-free operation. The maintenance of the water filter depends on the purity of the water used. Only use clean water!

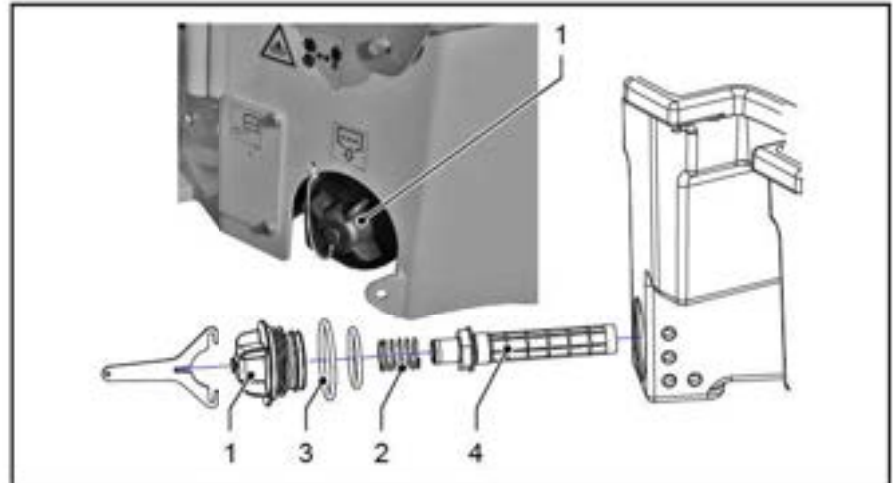

- ▶ Switch off diesel engine and remove ignition key.
- ▶ Unscrew the filter head [1] at the water tank and remove it together with the pressure spring [2] (pay attention to the sealing rings [3] on the filter head).
- ▶ Pull the filter insert [4] from the water tank.
- ▶ Clean filter insert and compression spring.



Empty the water tank when the filter has been removed.

- ▶ Place the filter insert [4] into the water tank.
- ▶ Screw the filter head [1] with sealing rings [3] together with the pressure spring [2] into the water tank.



The filter insert must be replaced by a new one when it is defective, worn out or cannot be cleaned.
For ordering, please contact the customer service.

4.08.05 Emptying and cleaning the water sprinkling system

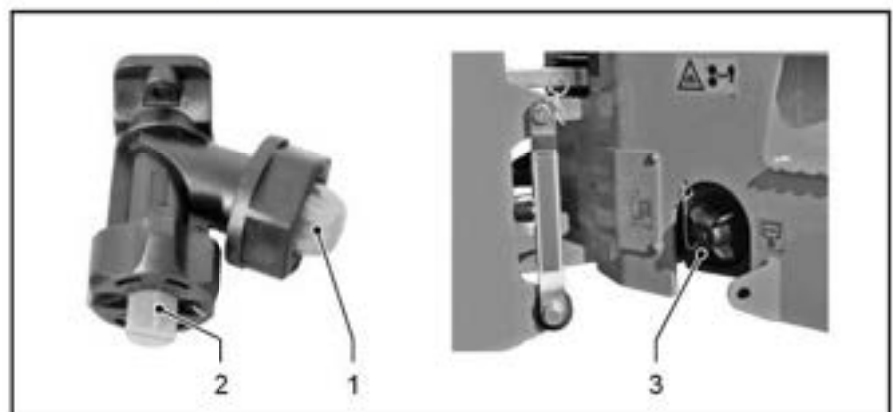

- ▶ Switch off diesel engine and remove ignition key.
- ▶ Remove the valve insert [1] with membrane and the sprinkler nozzles [2] with filter from the sprinkler nozzle casing.

- ▶ Unscrew the filter head [3] from the water tank and remove it together with the pressure spring (be careful with the sealing rings on the filter head).
- ▶ Pull the filter insert from the water tank.



Empty the water tank when the filter has been removed.



Before cleaning the water tank, remove the filter screen from the fill hole.

- ▶ Thoroughly clean the water tank with a water jet.
- ▶ Flush the sprinkler nozzle housings and the hoses.
- ▶ Insert filter insert in the water tank.
- ▶ Screw the filter head [3] together with the compression spring into the water tank.
- ▶ Insert valve insert [1] with the membrane as well as the sprinkler nozzles [2] with filter from the sprinkler nozzle housing.

4.08.06 Emptying and cleaning additive sprinkling system

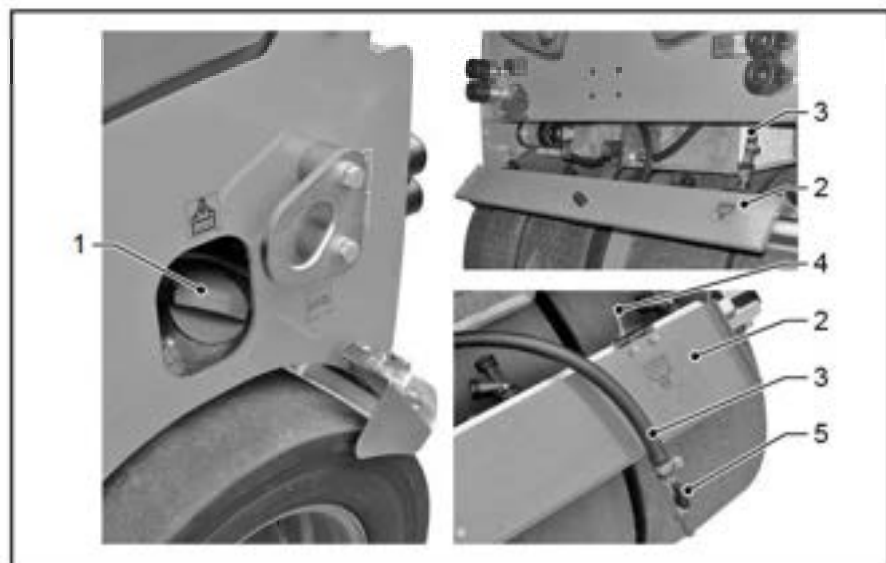

- ▶ Switch off the diesel engine and remove the ignition key.
- ▶ Open the tank cover for the additive tank [1] to allow the pressure to equalise.
- ▶ Open the maintenance flap [2].
- ▶ Prepare a suitable container to collect the contents of the tank.
- ▶ Remove the hose [3] from the holder [4].
- ▶ Open the drain outlet [5].
- ▶ Drain the additive-sprinkling tank.
- ▶ Catch and dispose of any release agent emulsion that flows out.



Observe the disposal regulations as specified by the additive manufacturer.

- ▶ After the tank has been drained, actuate the additive-sprinkling system until release agent emulsion no longer escapes from the spray nozzles.
- ▶ Thoroughly clean the additive tank with a water jet.
- ▶ Flush the spray nozzle housing and the hose lines.
- ▶ Close the drain outlet [5].
- ▶ Fit the hose [3] onto the holder [4].
- ▶ Close the maintenance flap [2].
- ▶ Close the additive tank cover [1].

4.09 Dynamic compaction system



Prior to maintenance works clean roller drums thoroughly.

4.09.01 Checking damping elements



- ▶ Switch off diesel engine and remove ignition key.
- ▶ Check the damping elements [1] of the roller drum suspension for cracks.
- ▶ Let replace damaged damping elements by new ones. Contact the customer service.

5 TABLES



When working at the machine please always adhere to the instructions given in your Safety instructions!

5.00 Technical data

5.00.01 Engine oil

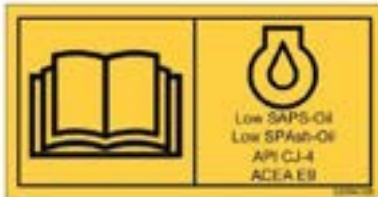

NOTICE

Wrong engine oil!

Using the wrong engine oil damages the engine, increases wear, lowers operational reliability and shortens the service life of the engine.

Statutory emission limits breached through using the wrong engine oil.

- Only use low ash engine oil in diesel engines that have an exhaust gas after-treatment system.
- Choose engine oil with a viscosity suitable for the operating temperature.
- Change the engine oil at the specified intervals!
- Do not mix different engine oils.

In order to avoid damaging the engine, each lubricating oil must have the viscosity suitable for its intended use.

Lubricating oil viscosity is classified in SAE viscosity grades. The following diagram shows the SAE viscosity grades in relation to the operating temperature.

Select the engine oil suitable for your operating temperature. Take account of the SAE viscosity grades. Use multigrade oils for work in widely ranging temperatures.

The cold starting ability of the engine can suffer if the temperature falls below the limit for a short period.

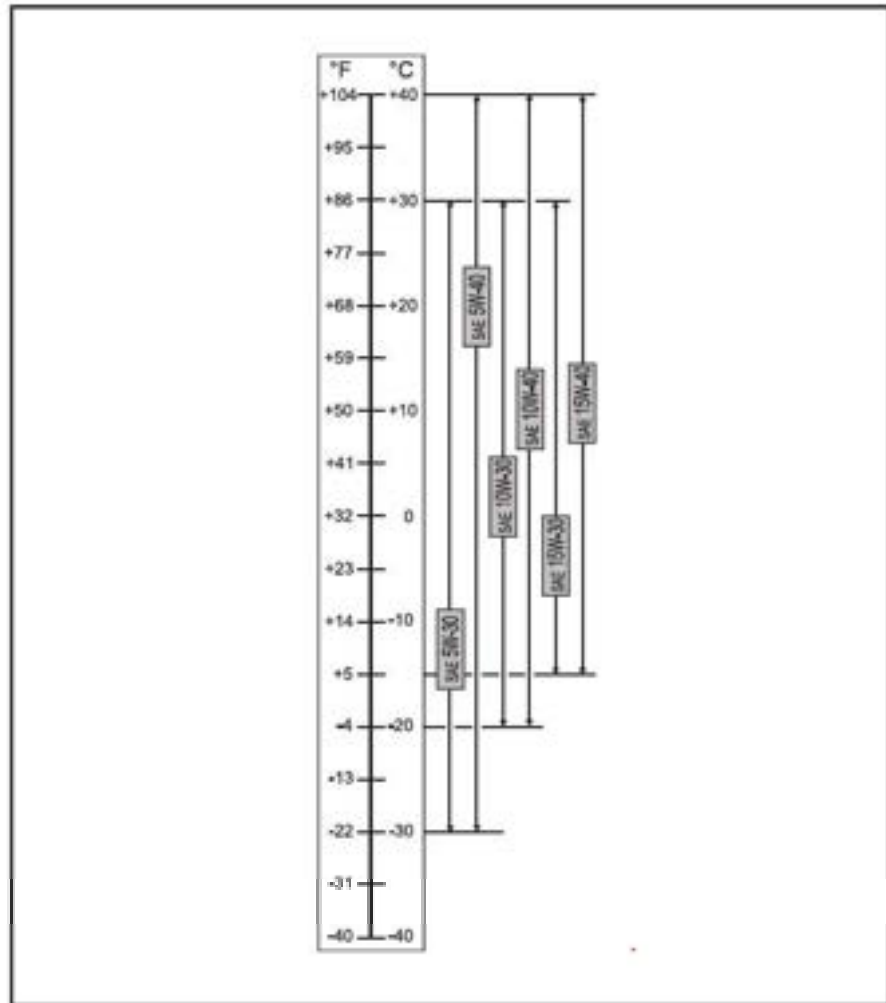



5.00.02 Fuel



NOTICE

Wrong fuel!

Using the wrong diesel fuel damages the engine, increases wear, lowers operational reliability and shortens the service life of the engine.

Statutory emission limits breached through using the wrong diesel fuel.

- Only use sulphur-free diesel fuel in diesel engines which have an exhaust gas after-treatment system (sulphur content ≤ 15 mg/kg).
- Only use diesel fuels that comply with EN 590 and ASTM D 975.



The certification measurements to measure the compliance with statutory emission limits are carried out using the test fuels specified by law. These test fuels correspond to the diesel fuels that comply with EN 590 and ASTM D 975, which are described in this operating manual. If other fuels are used, compliance with the legally specified emission values is not guaranteed.

The guarantee only applies to diesel fuels which comply with the permissible diesel fuel specifications.

The permissible diesel fuel specifications are:

- EN 590 (sulphur content ≤ 10 mg/kg (10 ppm))
- ASTM D 975-10 grade no. 1-D S15 and 2-D S15 (sulphur content ≤ 15 mg/kg)

Winter operation with diesel fuel

NOTICE

Low operating temperature!

Engine damage caused by adding liquids or additives to the diesel fuel at low operating temperatures.

Using the wrong diesel fuel can cause clogging of the fuel system at low operating temperatures.

- Do not add any benzene, petrol or fluidity additive to the diesel fuel.
- Use winter diesel fuel for working at temperatures between 0 °C (32 °F) and -20 °C (-4 °F)
- Use special diesel fuels for working in arctic climatic zones with temperature down to -44 °C (-47 °F).

5.00.03 Cooling liquid (coolant)

NOTICE

Wrong coolant additives!

Using the wrong coolant additives damages or impairs the function of the cooling system.

- Only use coolant additives recommended by manufacturer.
- Only mix cooling system protecting agents/additives with the same specification.



If no coolant or the wrong coolant is used, liquid-cooled diesel engines may be damaged by corrosion, cavitation and freezing.

Continually check the coolant level and the concentration of the cooling system protecting agent in liquid-cooled diesel engines. Create the necessary concentration of cooling system protecting agent by adding a cooling system protecting agent to the cooling water. Check the concentration of the cooling system protection agent with commercially available test devices (e. g. gefo glycomat®).

The concentration of the cooling system protection agent in the coolant must be as follows:

Crystallisation point	Coolant antifreeze	Water (distillate or completely demineralised)
-26 °C (-15 °F)	40 Vol.%	60 %
-37 °C (-34 °F)	50 Vol.%	50 %
-40 °C (-40 °F)	52 Vol.%	48 %

HAMM uses and recommends products free of nitrites, amines, silicates and phosphates. These are listed in the "Overview of service fluid specifications" section (see page 171). HAMM supplies all the machines filled with coolant blend of 50 parts cooling system protective liquid and 50 parts water. This ensures frost protection to -37 °C (-34 °F).

5.00.04 Hydraulic oil (mineral oil)

NOTICE

Wrong hydraulic oils!

Using the wrong hydraulic oils can damage or impair the function of the hydraulic system.

- Only use hydraulic oils recommended by manufacturer.
- Use only hydraulic oil with a viscosity appropriate for the working temperature.
- Only mix hydraulic oils with the same specification.

In order to avoid damaging the hydraulic system, each hydraulic oil must have the viscosity appropriate for its intended use.

The viscosity of hydraulic oil is classified in viscosity grades. The following diagram shows the viscosity grades as a function of the ambient temperature.

Select the hydraulic oil suitable for your ambient temperature. Take account of the viscosity grades.

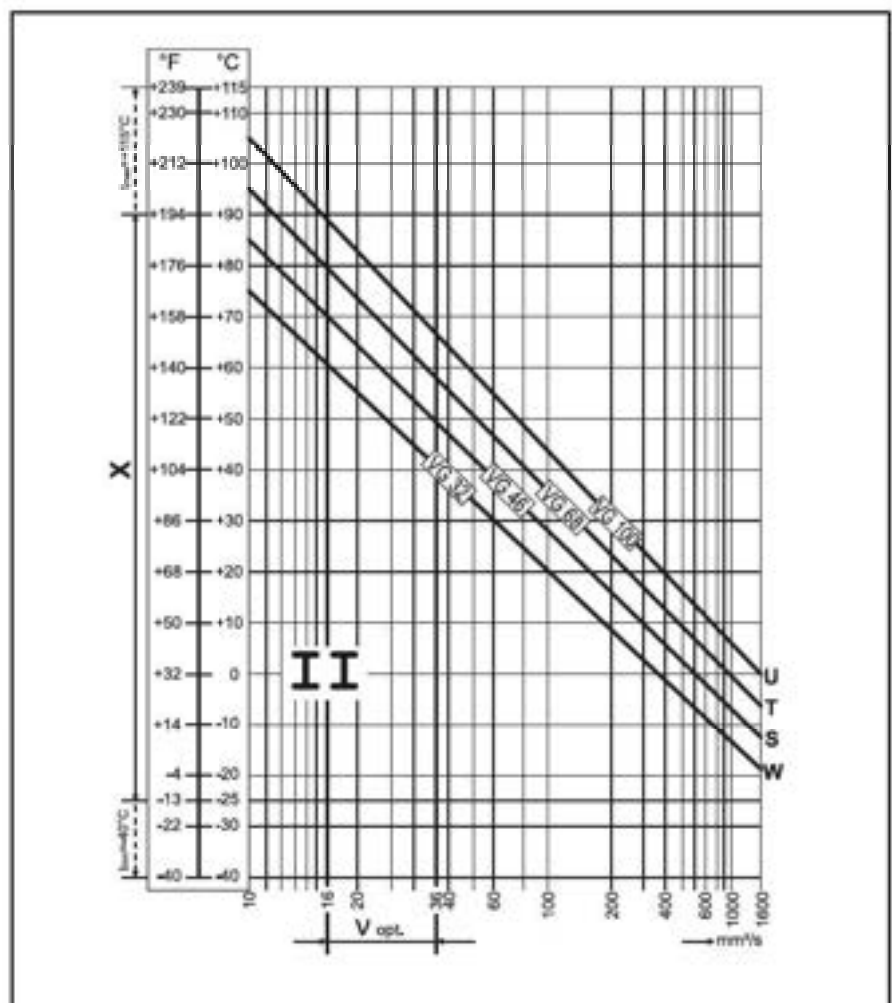

[W] Winter conditions in Central Europe

- [S] Summer conditions in Central Europe or in enclosed premises
- [T] Tropical conditions or in premises subject to high amounts of heat
- [U] Excessive amounts of heat (for example from combustion engines)
- [X] Pressure fluid temperature range
- [V_{opt}] Optimal operating viscosity range
- [1000 =] Maximum permissible (short-term) viscosity
- [II =] 100 mm²/s (t_{max} = +90 °C) ... 1000 mm²/s (t_{min} = -25 °C)

5.00.05 Biological hydraulic oil



NOTICE

Wrong hydraulic oils!

Using the wrong hydraulic oils can damage or impair the function of the hydraulic system.

- Only use hydraulic oils recommended by manufacturer.
- Use only hydraulic oil with a viscosity appropriate for the working temperature.
- Only mix hydraulic oils with the same specification.

The hydraulic system of the machine is supplied filled with mineral oil. All maintenance intervals in this maintenance manual relate to mineral oil.

Bio-hydraulic oil may be used under the following conditions:

- Use only bio-hydraulic oil based on specific, synthetic, saturated complex esters. The products used and recommended by manufacturer are listed in the "Overview of service fluid specifications" section ([see page 171](#)). Use other oils only when they correspond to the specifications of the oil above mentioned. The neutralization value (oil acid) may not exceed 2.
- When switching from bio-hydraulic oil to mineral oil or from mineral oil to bio-hydraulic oil, all filters in the oil circuit must be changed again after 50 operating hours. Then comply with the filter change intervals stated in this manual.
- Take old bio-oil and mineral oil to a reliable disposal center.
- Organic hydraulic fluid is easily biodegradable.

5.00.06 Wirtgen Group Asphalt Anti Stick

NOTICE

Incorrect mixing ratio of the asphalt separating agent!

Using the wrong mixing ratios can damage or ruin the rubber tires.

- Only use diluted Wirtgen Group Asphalt Anti Stick.
- Do not exceed the maximum mixing ratio (1:10).
- Follow this order: Always stir Wirtgen Group Asphalt Anti Stick into water.
- Only mix Wirtgen Group Asphalt Anti Stick with clean water.

Wirtgen Group Asphalt Anti Stick is an asphalt separating agent for pneumatic tired and combination rollers. It is supplied as a concentrate and has to be mixed with water. Wirtgen Group Asphalt Anti Stick is quickly biodegradable and non-toxic.

Processing:

Mix Wirtgen Group Asphalt Anti Stick with water in the desired ratio while stirring. Ensure thorough mixing.

A mixing ratio of 1:1 gives the most reliable results. However, this depends on the composition of the asphalt mix. Wirtgen Group Asphalt Anti Stick can be mixed with water in a mixing ratio of up to about 1:10.

5.00.07 Overview of lubricant details

Lubricant specifications

Lubricant	Quality	Viscosity	Marking
Engine oil The oil quality must correspond to the API/ACEA classification.	API: CJ-4/SM or higher ACEA: E9 or higher	See diagram	□
Hydraulic oil (mineral oil) The viscosity is defined in accordance with ISO 3448 (ISO-VG: Viscosity grade).	HVLP	Conditions ISO VG 22 arctic ISO VG 32 winter ISO VG 46 summer ISO VG 68 tropical ISO VG 100 extreme heat	□
Hydraulic oil (bio-hydraulic oil) Synthetic saturated ester (ISO-VG: Viscosity grade).	HEES		
Special oil Only HAMM special oil is admissible.			◇
Special oil Only HAMM special oil is admissible.			☆
Gear oil with limited slip additives. The oil quality must correspond to the API classification.	API GL-5	SAE 85W-90	○
Coolant for diesel engine, liquid-cooled (nitrite, amine and phosphate free). Mixture: 40% coolant concentrate, 60% water.			○
Grease Lithium saponified multi-purpose grease with high-pressure additives. Temperature application range from -25 °C (-13 °F) to +120 °C (248 °F).			△

For order numbers and pack size, see the WIRTGEN GROUP "Parts and More" document and WIRTGEN GROUP lubricants ([see page 173](#)).

5.00.08 Starting torques

The starting torques indicated within the tables apply to

- nuts and screws with headrest according to ISO 4014, 4032, 4762... (frictional coefficient $\mu_{\text{total}}=0.095$) unless otherwise specified.



Check the tightening torques of nuts and bolts at regular intervals. Tighten if necessary.

Starting torques for regular type screw threads

Threads (wrench size SW)	Starting torques MA (Nm)		
	8.8	10.9	12.9
M4 (SW7)	2.7	4.0	4.7
M5 (SW8)	5.5	8.1	9.5
M6 (SW10)	9.5	14	16.5
M8 (SW13)	21	30	36
M10 (SW16)	41	60	71
M12 (SW18)	71	104	122
M14 (SW21)	113	165	195
M16 (SW24)	175	255	300
M18 (SW27)	250	355	420
M20 (SW30)	350	500	580
M22 (SW34)	480	680	800
M24 (SW36)	600	860	1000
M27 (SW41)	880	1260	1470
M30 (SW46)	1200	1700	2000

Starting torques for fine threads

Threads (wrench size)	Starting torques MA (Nm)		
	8.8	10.9	12.9
M8x1 (SW13)	22	32	38
M10x1.25 (SW16)	43	63	74
M12x1.25 (SW18)	76	111	130
M12x1.5 (SW18)	73	108	126
M14x1.5 (SW21)	120	175	205
M16x1.5 (SW24)	183	265	315
M18x1.5 (SW27)	270	390	455
M20x1.5 (SW30)	380	540	630
M22x1.5 (SW34)	510	725	850
M24x2 (SW36)	640	910	1070
M27x2 (SW41)	930	1330	1550
M30x2 (SW46)	1300	1840	2150

5.00.09 Wirtgen Group Lubricants



General

Intensive testing and development work with leading mineral oil companies has analysed the complex and high requirements of Wirtgen Group machines. The results have been translated into optimal specifications and used for the first filling at the factory. This results in a wide range of premium lubricants from a single source accompanied by highly functional accessories for filling and lubrication.

Premium lubricants

Wirtgen Group lubricants have tailor-made specifications that combine high-quality base oils and additives. The advantages for you:

- Compatibility with the first filling
- Wear protection
- Corrosion prevention
- Traceability in the event of damage

Everything from a single source

HAMM rollers can be lubricated with the Wirtgen Group lubricant appropriate for the area of application. Together with the carefully coordinated mixture of container sizes, this results in optimised ordering, storage and filling processes.

Filling and lubricating accessories

Highly functional accessories, such as canister pumps and grease guns, are available to assist you in filling and lubricating your machines.

Engine oil <input type="checkbox"/>			
Designation	Description	Pack- ing size	Order no.
WIRTGEN GROUP Engine	Semi-synthetic "Low SAPS" engine oil (low sulphated ash, sulphur and phosphorous content) with fuel economy technology. Its low sulphate ash content ensures that burnt	5 l	2210320
		20 l	2210322
		208 l	2210323

Engine oil <input type="checkbox"/>			
Designation	Description	Pack- ing size	Order no.
Oil "Low SAPS" 10W-30	oil particles do not prematurely clog the exhaust gas after-treatment diesel particulate filter (DPF).	1000 l IBC	2118570
WIRTGEN GROUP Engine Oil "Low SAPS" 15W-40	Semi-synthetic "Low SAPS" engine oil (low sulphated ash, sulphur and phosphorous content) with fuel economy technology. Its low sulphate ash content ensures that burnt oil particles do not prematurely clog the exhaust gas after-treatment diesel particulate filter (DPF).	5 l	2573349
		20 l	2573350
		208 l	2573351
WIRTGEN GROUP Engine Oil "Low SAPS" 10W-40 MB	The very latest synthetic diesel engine oil, extremely high performance, "Low SAPS" (lower levels of sulphur, sulphated ash and phosphorus). This engine oil was specially developed for all diesel engines with a diesel particulate filter (DPF) and with SCR systems (AdBlue®). Reduces the environmental load thanks to reduced harmful emissions.	5 l	2346869
		20 l	2346870
		208 l	2346871

Hydraulic oil <input type="checkbox"/>			
Designation	Description	Pack- ing size	Order no.
WIRTGEN GROUP Hy- draulic Oil HVLP 32	High-grade multi-range hydraulic oil with zinc for a high level of protection against wear, even under difficult operating conditions. Enhanced specification results in much longer replacement intervals.	20 l	2118573
WIRTGEN GROUP Hy- draulic Oil HVLP 46	High-grade multi-range hydraulic oil with zinc for a high level of protection against wear, even under difficult operating conditions. Enhanced specification results in much longer replacement intervals.	20 l	2065028
		208 l	2065029
		1000 l IBC	2118571
WIRTGEN GROUP Hy- draulic Oil HVLP 68	High-grade multi-range hydraulic oil with zinc for a high level of protection against wear, even under difficult operating conditions. Enhanced specification results in much longer replacement intervals.	20 l	2118574

Biodegradable hydraulic oil <input type="checkbox"/>			
Designation	Description	Pack- ing size	Order no.
WIRTGEN GROUP Bio Hy- draulic Oil 46	Biodegradable multi-use hydraulic oil made from all-synthetic esters and ash-free additives results in optimal lubricating properties and a reduced load on the environment. Bears the EU Ecolabel for Lubricants.	20 l	2118575
		208 l	2270558
WIRTGEN GROUP Bio Hy- draulic Oil 68	Biodegradable multi-use hydraulic oil made from all-synthetic esters and ash-free additives results in optimal lubricating properties and a reduced load on the environment. Bears the EU Ecolabel for Lubricants.	20 l	2124179

Gear oil 			
Designation	Description	Pack- ing size	Order no.
WIRTGEN GROUP Gear Oil 85W-90	Mineral gearbox oil for versatile use in gearboxes and axle drives. Impresses with a high level of protection against wear and oxidation. Note: Do not use in HAMM vibration bearings or drum drives.	5 l	2065030
		20 l	2065031
		208 l	2065032

Special gear oil 			
Designation	Description	Pack- ing size	Order no.
WIRTGEN GROUP Special Gear Oil	Special fully synthetic, high-performance gear oil for HAMM vibration bearings. Highly resistant to pressure and temperature. Note: Do not mix with mineral gearbox oil.	5 l	1238051
		20 l	2065037
		208 l	2065038

Special gear oil 			
Designation	Description	Pack- ing size	Order no.
WIRTGEN GROUP Special Gear Oil	Special fully synthetic, high-performance gear oil for HAMM drum drives. Highly resistant to pressure and temperature. Note: Do not mix with mineral gearbox oil.	5 l	2571293
		20 l	2571294
		208 l	2571300

Greases 			
Designation	Description	Pack- ing size	Order no.
WIRTGEN GROUP Multi- purpose Grease	Highly refined multi-purpose grease for a wide range of lubrication tasks, such as on pivot pins and wheel bearings. Modern additive technology makes this product particularly suitable for use in conditions subject to impacts and vibration.	400 g	2065035
WIRTGEN GROUP Drum Bearing Grease	Exclusive grease for lubricating HAMM drum bearings. Highly resistant to temperature and pressure.	1 kg	1205757
WIRTGEN GROUP Drive Bearing Grease	Special high-performance grease for use in HAMM drive bearings. Extremely resistant to pressure and water-repellent.	1 kg	1227114

Diesel engine coolant ○			
Designation	Description	Pack- ing size	Order no.
WIRTGEN GROUP Antifreezing Compound	Anti-corrosion agents, coolants and anti-freeze for diesel engines.	5 l	2173022
		20 l	2173023
		208 l	2173024

Miscellaneous			
Designation	Description	Pack- ing size	Order no.
WIRTGEN GROUP Asphalt Anti Stick	Specially developed solution for combination and pneumatic tyre rollers from HAMM: It prevents bitumen from adhering to the rubber tyres. The emulsion is based on a non-toxic solution and is biodegradable.	5 l	2117378
		20 l	2117379



5.01 Technical data



The version valid at the time the technical data was prepared for this version of the manual was used (see impressum: change date). Other values may apply if modifications are made to the machine in the course of its further development.

5.01.01 HD 10 VV

Description	Value	Unit
Dimensions and weights		
Unladen weight without ROPS roll-over bar	2234	kg
Operating weight with ROPS roll-over bar	2475	kg
Front/rear axle load	1205/1270	kg
Working width/max. working width	1000/1050	mm
Inside/outside turning radius	2470/3470	mm
Diesel engine		
Manufacturer	Kubota	
Type	D1703	
Number of cylinders	3	
Power (ISO 14396)/rated speed	18.5/2200	kW/rpm
Exhaust emissions category EU/USA	V/EPA Tier 4	
Carbon dioxide emissions (CO ₂) ⁽¹⁾	938.3	g/kWh
Transmission		
Speed, infinitely variable	0-10.2/(0-6.3)	km/h / (mph)
Climbing ability, vibration on/off	30/40	%
Max. longitudinal incline allowed	20	°
Max. transverse incline allowed	20	°
Vibration		
Vibration	Front/rear	
Frequency/speed, engine speed max.	65/3900	Hz/rpm
Frequency/speed, engine speed 2/3 max.	51/3060	Hz/rpm
Maximum amplitude	0.45	mm
Steering		
Steering angle to both sides	32	°
Pendulum compensation upwards and downwards	8	°
Track offset		
Track offset to the right	50	mm
Filling capacities⁽²⁾		
Fuel	42.00	l
Engine oil (for oil change)	7.00	l
Diesel engine coolant	8.00	l
Hydraulic oil	26.00	l

Description	Value	Unit
Water sprinkling system	180.00	l
Sound power level		
Sound power level L_{WA} , guaranteed	106	dB(A)
Sound power level L_{WA} , representative measurement	104	dB(A)
Emissions sound pressure level at the driver's seat		
Sound pressure level L_{PA} , measured with cab, max.	Not available	
Sound pressure level L_{PA} , measured with ROPS, max.	89	dB(A)
Electrical system		
Operating voltage	12	V

5.01.02 HD 10 VO

Description	Value	Unit
Dimensions and weights		
Unladen weight without ROPS roll-over bar	2284	kg
Operating weight with ROPS roll-over bar	2525	kg
Front/rear axle load	1205/1320	kg
Working width/max. working width	1000/1050	mm
Inside/outside turning radius	2470/3470	mm
Diesel engine		
Manufacturer	Kubota	
Type	D1703	
Number of cylinders	3	
Power (ISO 14396)/rated speed	18.5/2200	kW/rpm
Exhaust emissions category EU/USA	V/EPA Tier 4	
Carbon dioxide emissions (CO ₂) ⁽¹⁾	938.3	g/kWh
Transmission		
Speed, infinitely variable	0-10.2/(0-6.3)	km/h / (mph)
Climbing ability, dynamic compaction system on/off	30/40	%
Max. longitudinal incline allowed	20	°
Max. transverse incline allowed	20	°
Vibration		
Vibration	front	
Frequency/speed, engine speed max.	65/3900	Hz/rpm
Frequency/speed, engine speed 2/3 max.	51/3060	Hz/rpm
Maximum amplitude	0.45	mm
Oscillation		
Oscillation	rear	
Frequency/speed, engine speed max.	38/2280	Hz/rpm
Frequency/speed, engine speed 2/3 max.	29/1740	Hz/rpm
Tangential amplitude	1.34	mm
Steering		
Steering angle to both sides	32	°
Pendulum compensation upwards and downwards	8	°
Track offset		
Track offset to the right	50	mm
Filling capacities⁽³⁾		
Fuel	42.00	l
Engine oil (for oil change)	7.00	l
Diesel engine coolant	8.00	l

Description	Value	Unit
Hydraulic oil	26.00	l
Water sprinkling system	180.00	l
Sound power level		
Sound power level L_{WA} , guaranteed	106	dB(A)
Sound power level L_{WA} , representative measurement	104	dB(A)
Emissions sound pressure level at the driver's seat		
Sound pressure level L_{PA} , measured with cab, max.	Not available	
Sound pressure level L_{PA} , measured with ROPS, max.	89	dB(A)
Electrical system		
Operating voltage	12	V

5.01.03 HD 10 VT

Description	Value	Unit
Dimensions and weights		
Unladen weight without ROPS roll-over bar	2134	kg
Operating weight with ROPS roll-over bar	2385	kg
Front/rear axle load	1210/1175	kg
Axle load per tyre	293.75	kg
Working width/max. working width	1000/1050	mm
Inside/outside turning radius	2470/3470	mm
Diesel engine		
Manufacturer	Kubota	
Type	D1703	
Number of cylinders	3	
Power (ISO 14396)/rated speed	18.5/2200	kW/rpm
Exhaust emissions category EU/USA	V/EPA Tier 4	
Carbon dioxide emissions (CO ₂) ⁽¹⁾	938.3	g/kWh
Transmission		
Speed, infinitely variable	0-9.6/(0-6.0)	km/h / (mph)
Climbing ability, vibration on/off	30/40	%
Max. longitudinal incline allowed	20	°
Max. transverse incline allowed	20	°
Tyres		
Tyre size	205/60-R15	
Number of rear tyres	4	items
Weight of tyres	30	kg
Air pressure	0.3/(3.0)/[44]	MPa/(bar)/[psi]
Tightening torque, wheel nut	170	Nm
Vibration		
Vibration	front	
Frequency/speed, engine speed max.	65/3900	Hz/rpm
Frequency/speed, engine speed 2/3 max.	51/3060	Hz/rpm
Maximum amplitude	0.45	mm
Steering		
Steering angle to both sides	32	°
Pendulum compensation upwards and downwards	8	°
Track offset		
Track offset to the right	50	mm
Filling capacities⁽³⁾		
Fuel	42.00	l
Engine oil (for oil change)	7.00	l

Description	Value	Unit
Diesel engine coolant	8.00	l
Hydraulic oil	26.00	l
Water sprinkling system	180.00	l
Additive sprinkling system	18.00	l
Sound power level		
Sound power level L_{WA} , guaranteed	106	dB(A)
Sound power level L_{WA} , representative measurement	104	dB(A)
Emissions sound pressure level at the driver's seat		
Sound pressure level L_{pA} , measured with cab, max.	Not available	
Sound pressure level L_{pA} , measured with ROPS, max.	89	dB(A)
Electrical system		
Operating voltage	12	V

5.01.04 HD 12 VV

Description	Value	Unit
Dimensions and weights		
Unladen weight without ROPS roll-over bar	2454	kg
Operating weight with ROPS roll-over bar	2695	kg
Front/rear axle load	1335/1360	kg
Working width/max. working width	1200/1250	mm
Inside/outside turning radius	2370/3570	mm
Diesel engine		
Manufacturer	Kubota	
Type	D1703	
Number of cylinders	3	
Power (ISO 14396)/rated speed	18.5/2200	kW/rpm
Exhaust emissions category EU/USA	V/EPA Tier 4	
Carbon dioxide emissions (CO ₂) ⁽¹⁾	938.3	g/kWh
Transmission		
Speed, infinitely variable	0-10.2/(0-6.3)	km/h / (mph)
Climbing ability, vibration on/off	30/40	%
Max. longitudinal incline allowed	20	°
Max. transverse incline allowed	20	°
Vibration		
Vibration	Front/rear	
Frequency/speed, engine speed max.	65/3900	Hz/rpm
Frequency/speed, engine speed 2/3 max.	51/3060	Hz/rpm
Maximum amplitude	0.45	mm
Steering		
Steering angle to both sides	32	°
Pendulum compensation upwards and downwards	8	°
Track offset		
Track offset to the right	50	mm
Filling capacities⁽³⁾		
Fuel	42.00	l
Engine oil (for oil change)	7.00	l
Diesel engine coolant	8.00	l
Hydraulic oil	26.00	l
Water sprinkling system	180.00	l
Sound power level		
Sound power level L _{WA} , guaranteed	106	dB(A)
Sound power level L _{WA} , representative measurement	104	dB(A)

Description	Value	Unit
Emissions sound pressure level at the driver's seat		
Sound pressure level L_{pA} , measured with cab, max.	Not available	
Sound pressure level L_{pA} , measured with ROPS, max.	89	dB(A)
Electrical system		
Operating voltage	12	V

5.01.05 HD 12 VO

Description	Value	Unit
Dimensions and weights		
Unladen weight without ROPS roll-over bar	2514	kg
Operating weight with ROPS roll-over bar	2755	kg
Front/rear axle load	1335/1420	kg
Working width/max. working width	1200/1250	mm
Inside/outside turning radius	2370/3570	mm
Diesel engine		
Manufacturer	Kubota	
Type	D1703	
Number of cylinders	3	
Power (ISO 14396)/rated speed	18.5/2200	kW/rpm
Exhaust emissions category EU/USA	V/EPA Tier 4	
Carbon dioxide emissions (CO ₂) ⁽¹⁾	938.3	g/kWh
Transmission		
Speed, infinitely variable	0-10.2/(0-6.3)	km/h / (mph)
Climbing ability, dynamic compaction system on/off	30/40	%
Max. longitudinal incline allowed	20	°
Max. transverse incline allowed	20	°
Vibration		
Vibration	front	
Frequency/speed, engine speed max.	65/3900	Hz/rpm
Frequency/speed, engine speed 2/3 max.	51/3060	Hz/rpm
Maximum amplitude	0.45	mm
Oscillation		
Oscillation	rear	
Frequency/speed, engine speed max.	38/2280	Hz/rpm
Frequency/speed, engine speed 2/3 max.	29/1740	Hz/rpm
Tangential amplitude	1.14	mm
Steering		
Steering angle to both sides	32	°
Pendulum compensation upwards and downwards	8	°
Track offset		
Track offset to the right	50	mm
Filling capacities⁽³⁾		
Fuel	42.00	l
Engine oil (for oil change)	7.00	l
Diesel engine coolant	8.00	l

Description	Value	Unit
Hydraulic oil	26.00	l
Water sprinkling system	180.00	l
Sound power level		
Sound power level L_{WA} , guaranteed	106	dB(A)
Sound power level L_{WA} , representative measurement	104	dB(A)
Emissions sound pressure level at the driver's seat		
Sound pressure level L_{PA} , measured with cab, max.	Not available	
Sound pressure level L_{PA} , measured with ROPS, max.	89	dB(A)
Electrical system		
Operating voltage	12	V

5.01.06 HD 12 VT

Description	Value	Unit
Dimensions and weights		
Unladen weight without ROPS roll-over bar	2344	kg
Operating weight with ROPS roll-over bar	2595	kg
Front/rear axle load	1340/1255	kg
Axle load per tyre	313.75	kg
Working width/max. working width	1200/1220	mm
Inside/outside turning radius	2370/3570	mm
Diesel engine		
Manufacturer	Kubota	
Type	D1703	
Number of cylinders	3	
Power (ISO 14396)/rated speed	18.5/2200	kW/rpm
Exhaust emissions category EU/USA	V/EPA Tier 4	
Carbon dioxide emissions (CO ₂) ⁽¹⁾	938.3	g/kWh
Transmission		
Speed, infinitely variable	0-9.6/(0-6.0)	km/h / (mph)
Climbing ability, vibration on/off	30/40	%
Max. longitudinal incline allowed	20	°
Max. transverse incline allowed	20	°
Tyres		
Tyre size	9.5/65-15	
Number of rear tyres	4	items
Weight of tyres	45	kg
Air pressure	0.3/(3.0)/[44]	MPa/(bar)/[psi]
Tightening torque, wheel nut	170	Nm
Vibration		
Vibration	front	
Frequency/speed, engine speed max.	65/3900	Hz/rpm
Frequency/speed, engine speed 2/3 max.	51/3060	Hz/rpm
Maximum amplitude	0.45	mm
Steering		
Steering angle to both sides	32	°
Pendulum compensation upwards and downwards	8	°
Track offset		
Track offset to the right	50	mm
Filling capacities⁽³⁾		
Fuel	42.00	l
Engine oil (for oil change)	7.00	l

Description	Value	Unit
Diesel engine coolant	8.00	l
Hydraulic oil	26.00	l
Water sprinkling system	180.00	l
Additive sprinkling system	18.00	l
Sound power level		
Sound power level L_{WA} , guaranteed	106	dB(A)
Sound power level L_{WA} , representative measurement	104	dB(A)
Emissions sound pressure level at the driver's seat		
Sound pressure level L_{pA} , measured with cab, max.	Not available	
Sound pressure level L_{pA} , measured with ROPS, max.	89	dB(A)
Electrical system		
Operating voltage	12	V

- (1) This CO₂ measurement is the result of testing a (parent) engine that is representative of the engine type or the engine family in a fixed test cycle under laboratory conditions, and it does not represent an explicit or implicit guarantee for the performance of a specific engine.
- (3) The specifications for the filling capacities of liquids and operating materials refer to the standard version of machine. However, they may deviate, e.g. for hydraulic oil and where attachments and auxiliary devices are installed. Always observe the operating manual when filling. Fill liquids and operating materials up to the respective mark.

5.02.03 HD 12 (VV, VO)

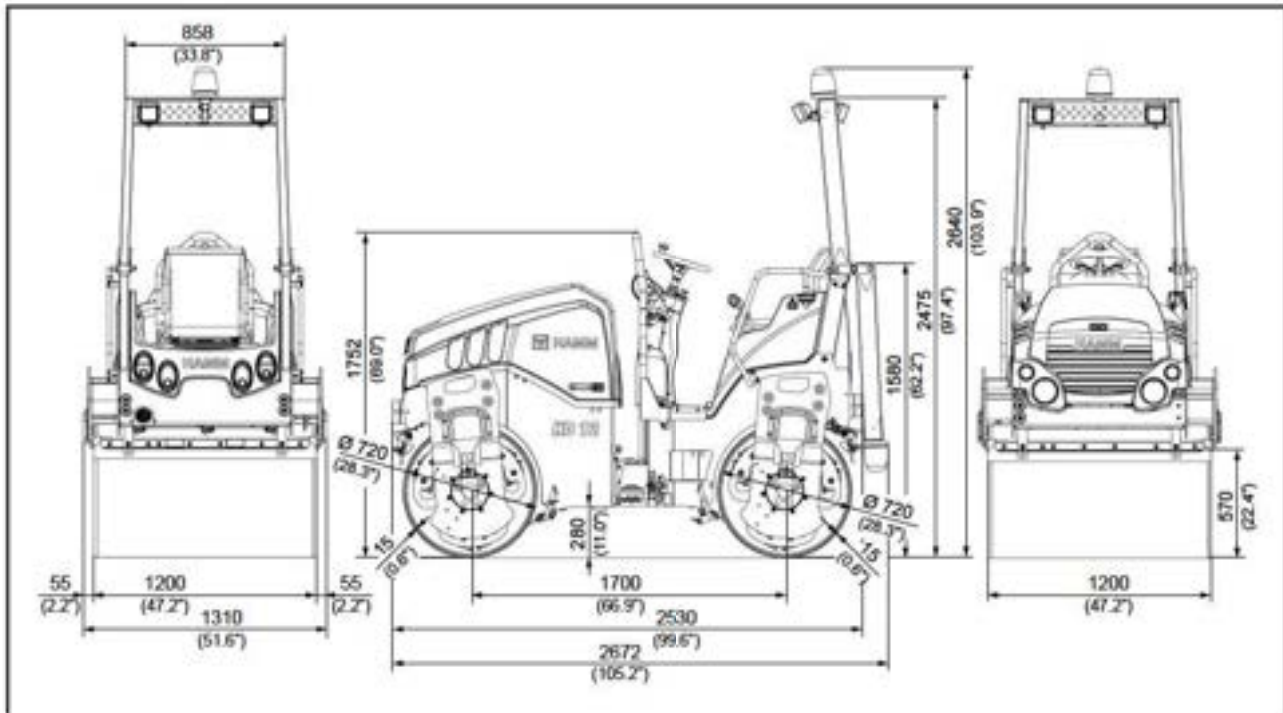

5.02.04 HD 12 VT

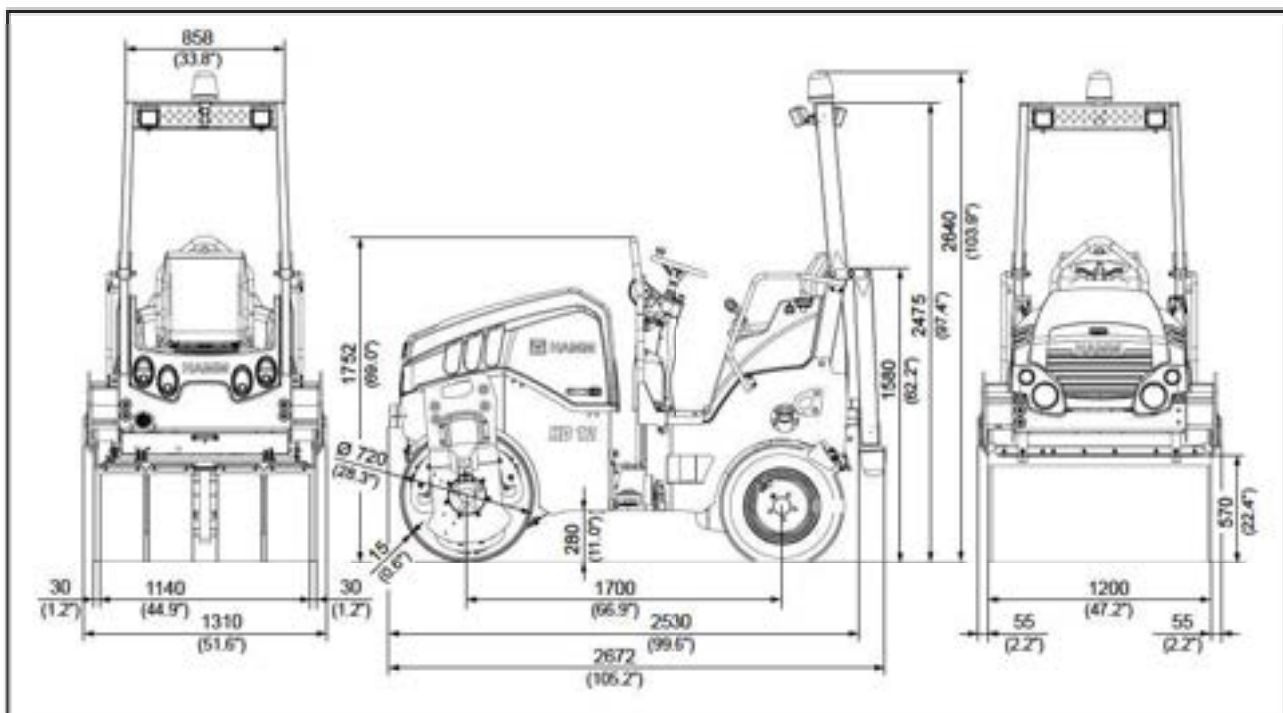

5.03 Fuses

▲ WARNING

Fire in the machine electrical system!

Serious injuries or death or material damage as a result of fire caused by using fuses not meeting specifications.

- Only use fuses specified by the manufacturer (not fuses with a higher amperage).
- Do not bridge fuses.



The fuse assignment indicates a fully equipped machine. Depending on the machine configuration (special attachments), slots are correspondingly free or occupied by fuses. Please follow the fuse assignment shown on the adhesive label in the engine compartment.

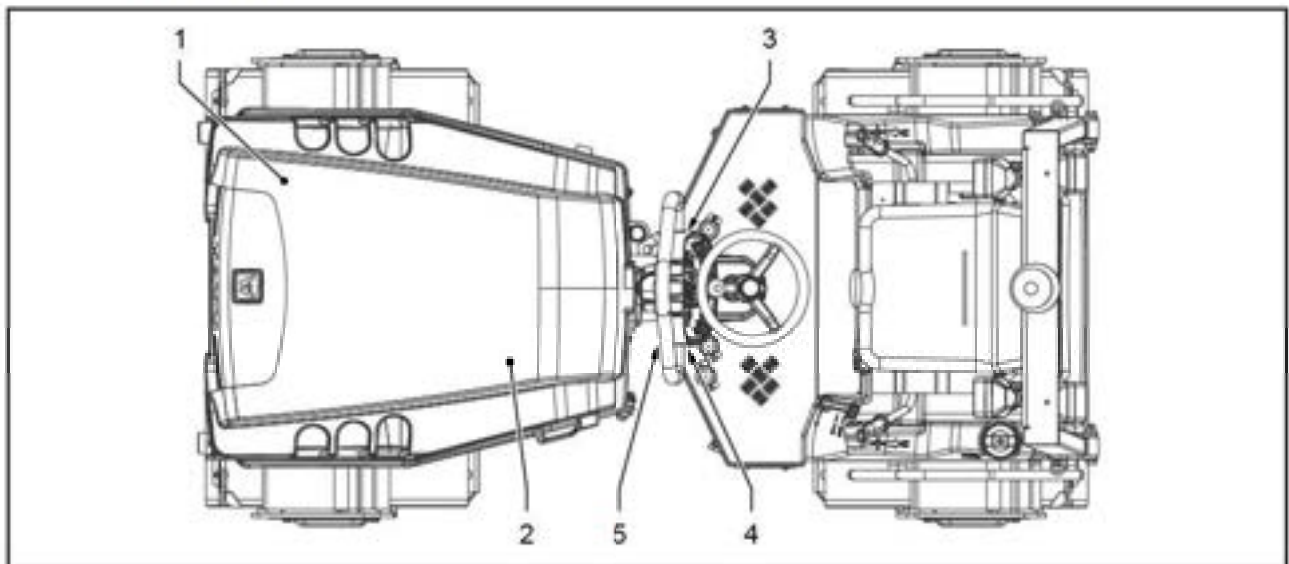

[1]	Main fuses	[2]	Options 1
[3]	Central electrical system	[4]	Central electrical system/options 2
[5]	Options 3		

5.03.01 Engine compartment

[1] Main fuses

Position	Fuse assignment	Fuse
F01	Internal power supply	80 A
F02	not used	
F03	not used	
F04	not used	

[2] Options 1

Position	Fuse assignment	Fuse
F200	Engine rpm counter/engine revolution counter	5 A

5.03.02 Steering column

[3] Central electrical system

Component	Fuse assignment	Fuse
F1	All-wheel lock	5 A
F2	Cold start assistance time relay	1 A
F3	Drum edge lighting	15 A
F4	Driving light, left	10 A
F5	Driving light, right	10 A
F6	Reversing lights	15 A
F7	Working spotlights	15 A
F8	Cold start assistance indicator light	5 A
F9	Not assigned	5 A
F10	Water sprinkling foot pedal	15 A
F11	Additive sprinkling foot pedal, seat heating	15 A
F12	WIFMS Gateway	10 A
F13	Socket	15 A
F14	Signal horn	15 A
F15	Additive sprinkling pump	15 A
F16	Water sprinkling pump	15 A
F17	Rotating beacon	15 A
FT	Plug-in socket for fuse test	

[4] Central electrical system/option 2

Component	Fuse assignment	Fuse
F18	Back-up alarm	15 A
F19	Fuel pump, alternator	7.5 A
F20	TCU (terminal 15)	7.5 A
F21	TCU (terminal 30)	7.5 A
F41	WIDIAG diagnostic interface	7.5 A
F42	Not assigned	5 A

5.03.03 Dashboard/control panel

[5] Options 3

Component	Fuse assignment	Fuse
F40	not used	7.5 A
F401	Track unit (terminal 30)	7.5 A
F402	Track unit (terminal 15)	7.5 A



You can use the fusible test receptacle to check a fuse.
The green light-emitted diode (LED) lights up when the fuse is functional.

5.04 Diagnostic code

Code no.	Component	Possible cause
100	Driving light	Open line, short circuit
102	Rotating beacon	Open line, short circuit
103	Additive sprinkling pump	Open line, short circuit
104	Drum edge lighting	Open line, short circuit
105	Reversing light	Open line, short circuit
106	Water sprinkling pump	Open line, short circuit
107	Signal horn	Open line, short circuit
110	Working spotlight, left	Open line, short circuit
111	Working spotlight, right	Open line, short circuit
112	Stop solenoid	Open line, short circuit
113	Starter relay	Open line, short circuit
114	Rear solenoid valve vibration	Open line, short circuit
116	Alert buzzer	Open line, short circuit
117	Travel pump	Open line, short circuit
118	Left turn signal	Open line, short circuit
119	Parking light, left	Open line, short circuit
122	Parking brake	Open line, short circuit
123	Solenoid valve vibration, front	Open line, short circuit
124	Back-up alarm	Open line, short circuit
125	All-wheel lock	Open line, short circuit
126	Parking light, right	Open line, short circuit
127	Right turn signal	Open line, short circuit
128	Water-sprinkling system	Internal plausibility error
129	Solenoid valve vibration front or rear	Internal plausibility error
160	Machine CAN BUS	Internal plausibility error
161	Internal memory	Internal plausibility error
164	Hydraulic oil pressure or temperature sensor	Short circuit, mechanical defect
165	Drive lever	Implausible signal
166	Starting conditions	Implausible signal

6 AUXILIARY EQUIPMENT

The section describes the mounting and dismounting, operation and maintenance of special attachments.



Please consider the parts included in the scope of supply. They may be different from the parts list content indicated here due to further developments in the product.

Safety Instructions

The "Special attachments" section describes components of the machine, that can be operated in addition to the equipment previously described in the manual.

For the special attachments, observe **ALL** the general warning and safety notices listed in the Operation and Maintenance chapter.

- "Important information about operating the machine"
- "Important information about maintenance works"



When working at the machine please always adhere to the instructions given in your Safety instructions!



6.00 Roll-over protection structure (ROPS)

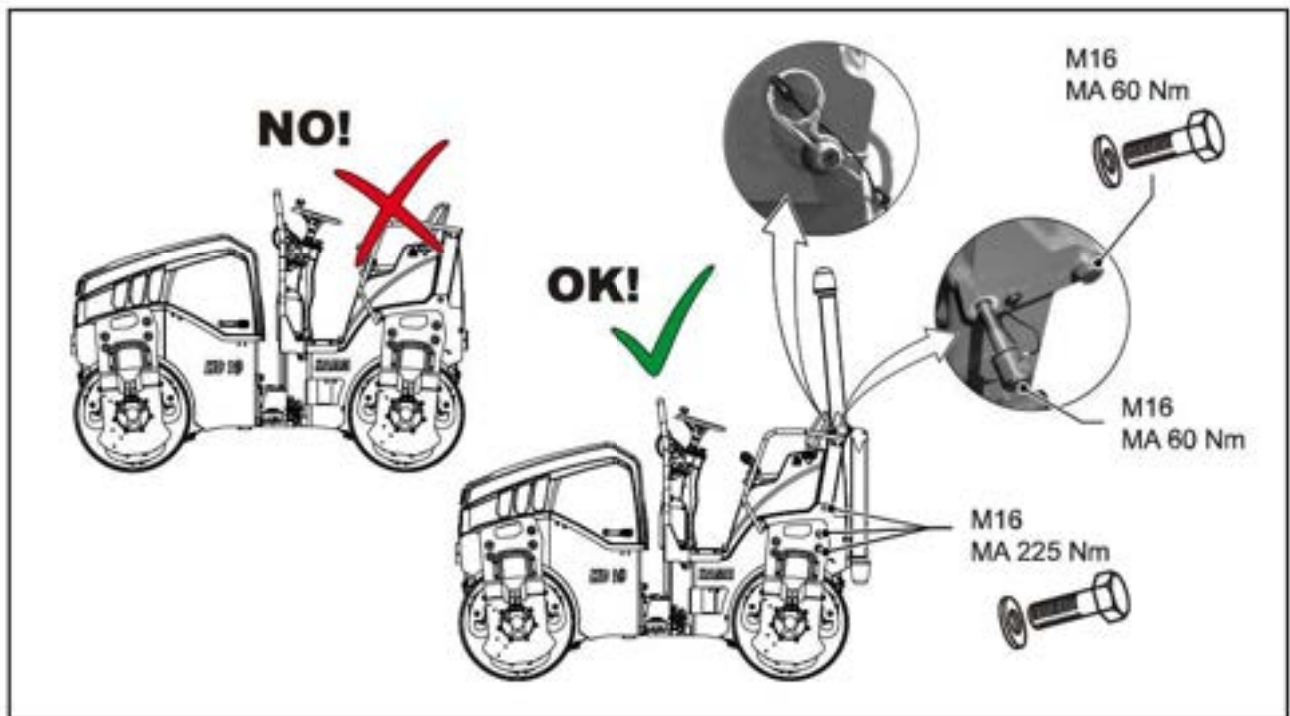

The ROPS safety device (cab/roll-over bar) is a rollover protection structure in the case the machine tilts or rolls over. It avoids that the driver is crushed to death based on the high self-weight of the machine.

If the ROPS safety equipment is dismantled from the machine for transport or repair, it must be remounted according to specifications before the machine is used again.

▲WARNING

High self-weight of machine!

If the machine overturns backwards, forwards or sideways there is a danger of serious injuries or death.

- Operate machine only with the ROPS safety device installed according to instructions and while wearing the safety belt.
- With detectable defects of the ROPS safety device or of its fixation it is not allowed to operate the machine.

Assembly

▲WARNING

High self-weight of ROPS safety device!

Serious injuries or death caused by crushing or getting caught during assembly.

- Perform installation work on firm ground (flat, stable, horizontal).
- Carry out fitting work only when the engine is stopped.
- Use suitable load suspension and hitching gear with an adequate loading capacity.
- Do not step underneath suspended loads.



Observe the service manual for mounting the ROPS safety equipment.

- ▶ Use appropriate lifting devices and hoisting equipment. Observe weight (see type plate of ROPS safety device).
- ▶ Lift ROPS safety device onto platform and align with fixing holes.
- ▶ Screw ROPS safety device with operator platform. Observe specified starting torque values.

With a ROPS design (hinged):

- ▶ Turn up and screw the upper frame part with threaded studs. Apply the specified tightening torque.
- ▶ Secure the threaded stud with a spring cotter pin.

Visual test

The machine frame must not be warped, bent or cracked in the ROPS fixing area (deformation).

The reinforcement elements of the ROPS safety device must not show rust, damage, fissures or open fractures.

All screw connections of the reinforcement elements must comply with the given specifications and must be screwed tightly to each other (observe starting torque values). Bolts and nuts must not be damaged, bent or deformed.

It is absolutely forbidden to modify or repair/level the reinforcement elements in any way.



6.01 Falling-object protective structure (FOPS)

The FOPS safety equipment is a design that prevents the driver from being injured by falling objects.

If available, the FOPS safety equipment is integrated into the cab roof or weather protection roof, depending on the machine's equipment. The FOPS material number is then shown on the ROPS type plate.

If a design with FOPS safety equipment is dismantled from the machine for transport or repair, it must be remounted according to specifications before the machine is used again.

Installation



A damaged FOPS component must only be installed or replaced by specialist personnel who are trained to do so. Inform customer service.

6.02 Rotating beacon

6.02.01 Overview



[1]	Rotating light mounted	[2]	Contact tube
[3]	Clamping screw	[4]	Plug contact

6.02.02 Description

The rotating beacon is an orange warning light that radiates light over a 360° area.

A switched on rotating beacon visual identifies, marks and safeguards danger areas.

6.02.03 Mounting/Dismounting

▲ WARNING

Work above floor level!

Risk of injury caused by falling.

- All work above floor level must only be carried out using a stable ladder or on maintenance scaffolding.
- To reach the maintenance points on the machine, use the designated steps and treads. Do not step on any other machine element or add-on part.



Mounting rotating beacon

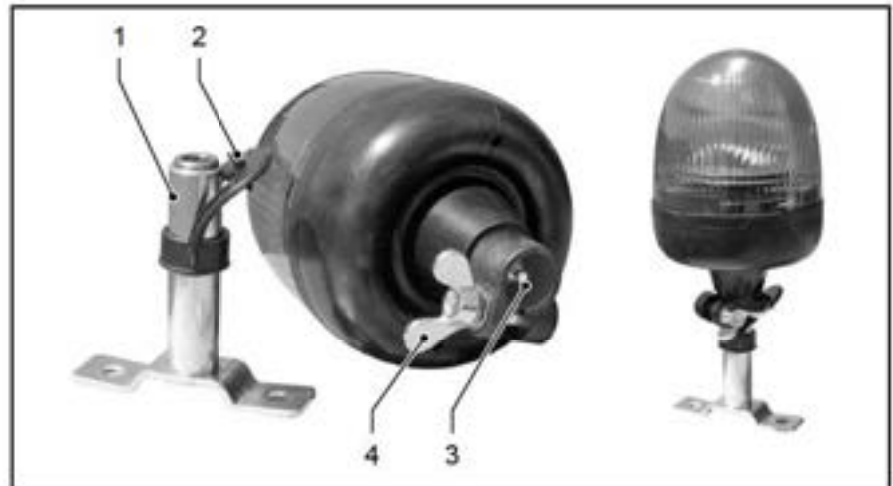

- ▶ Swivel the protective cap [2] to the side.
- ▶ Put the locating hole [3] of the rotating beacon on the contact tube [1] and slide it up to the stop.
- ✓ The electrical connection has been made.
- ▶ Tighten clamping screw [4].

Dismounting/removing rotating beacon

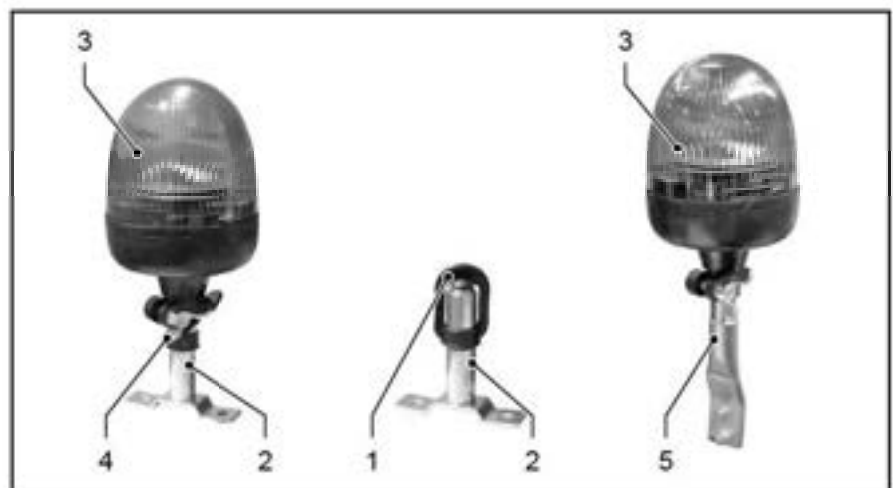

- ▶ Unscrew the clamping screw [4] and slide the rotating beacon [3] off the contact tube [2].
- ▶ Close the contact tube [2] with the protective cap [1].
- ▶ Stow the rotating beacon [3] on the holder [5] inside the cab.

Rotating beacon, foldable

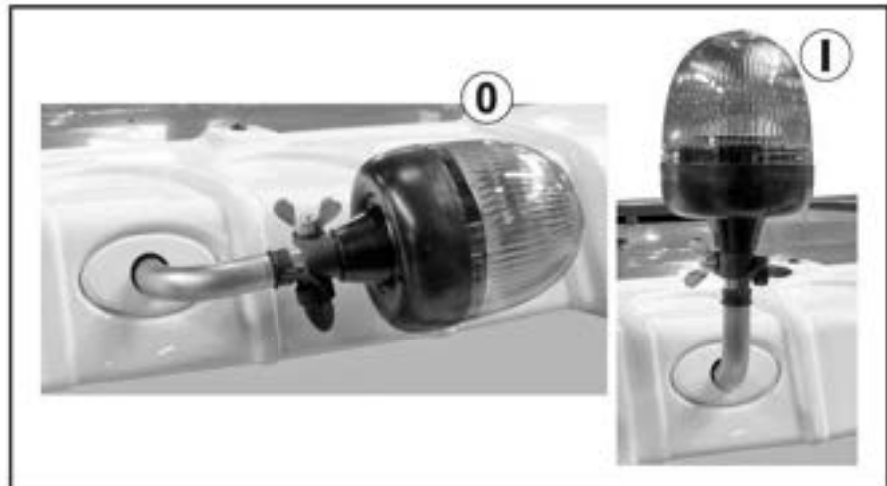

The rotating beacon can be turned through 90 degrees to reduce the height of the machine for transport on a low loader or truck.

- ▶ Move the rotating beacon to lock-in position 0 for transport.
- ▶ Move the rotating beacon to lock-in position I for work.

6.02.04 Operation

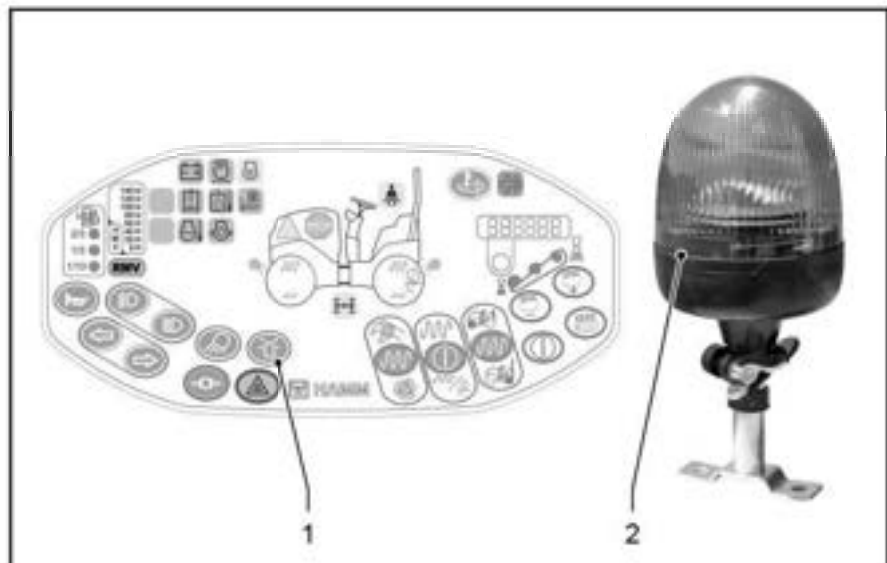

Switching on rotating beacon

- ▶ Press the rotating beacon switch [1] on the control panel.
- ✓ LED on: Rotating beacon [2] lights.

Switching off rotating beacon

- ▶ Press the rotating beacon [1] switch on the control panel again.
- ✓ LED off: Rotating beacon [2] off.



6.02.05 Maintenance

▲ WARNING

Work above floor level!

Injury caused by falling.

- Do not perform any maintenance or repair work above ground level unless using a stable ladder or a maintenance scaffold.
- To reach the maintenance points on the machine, use the steps indicated. Do not step on any other machine element or add-on part.



Dust or sand can impair the function of the rotating beacon.

Cleaning

- ▶ Use a sponge and soap water to clean the rotating beacon.
- ▶ Do not clean the rotating beacon with a water jet or high-pressure cleaner.

Maintenance

- ▶ Spray electrical contacts using a contact spray.

6.03 Anti-freeze filling system for water sprinkling

6.03.01 Overview

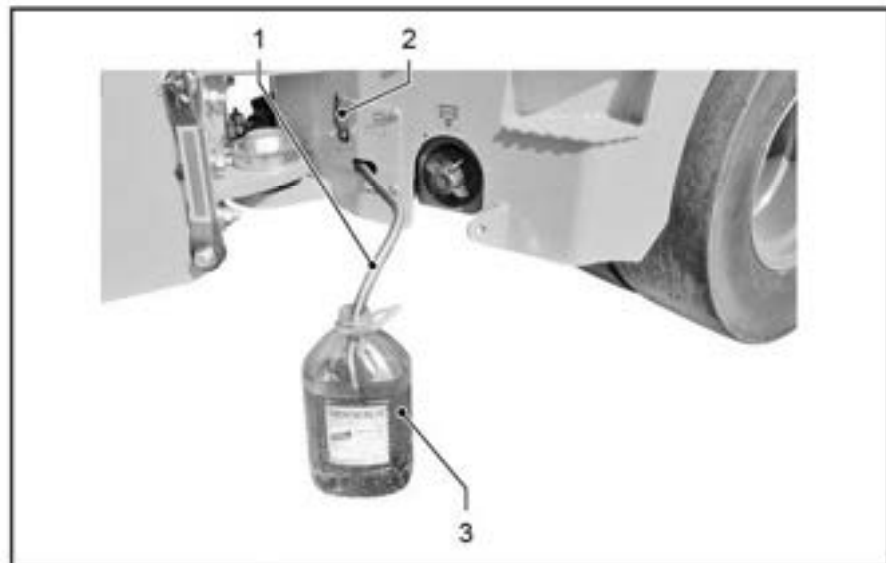

[1]	Hose	[2]	Change-over valve
[3]	Vessel for antifreeze solution		

6.03.02 Description

The anti-freeze filling system fills the pipes of the water sprinkling unit with antifreeze. This helps to prevent the sprinkler system from freezing and thus the sprinkler nozzles from being destroyed when there is any risk of frost.

6.03.03 Operation

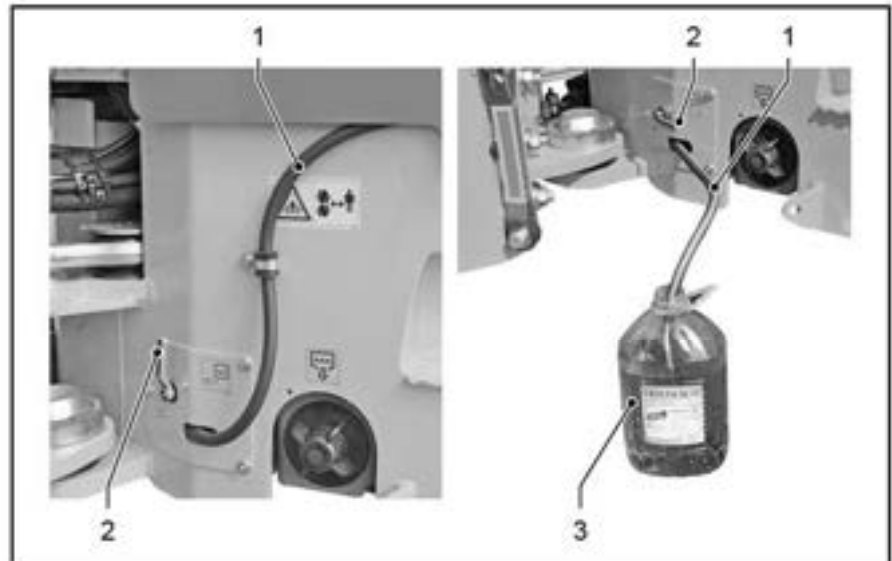

- Use a commercially available antifreeze solution for windscreen washing systems when filling the piping system.
- Match the mixing ratio with water to the expected temperatures.

Fill the piping system

- ▶ Switch off the diesel engine.
- ▶ Water sprinkling system functional test: Switch the water sprinkling system on when the machine is at a standstill (see page 93).
- ▶ Take the hose [1] out of its holder.
- ▶ Clean the end of the hose if it is dirty.
- ▶ Insert the hose into the container [3] containing antifreeze solution.
- ▶ Set the change over valve [2] to the anti-freeze filling system position.
- ▶ Fill the piping system until the antifreeze solution exudes out of all the spray nozzles.
- ▶ Switch off the sprinkler.
- ▶ Switch off the electrical system, and remove the ignition key.
- ▶ Put the hose [1] back in its holder.
- ▶ Set the switchover valve [2] to sprinkle.